

## CHAPTER 9

### CO45XL

The **CO45XL** is a compact heater, totally self contained to provide heat for space heating, domestic water heating, and engine heating, each with a separate hook up for easy installation.

The following itemizes some key features specific to the CO45XL model only. Refer to the other chapters in this manual for further details

The main burner is diesel fired and has 2 - 2KW 120 Volt electric elements wrapped around the water jacket. This provides some or all the heat when plugged into ac power. All the working components including the expansion tank, water circulating pumps, valves, heat exchangers, are built into a single stainless steel enclosure and are accessible from the top and left side of the heater when looking at it from the front. The front contains the burner components. The heater must be accessible from the top, front, and left-hand side. See figure 9-3.

#### 9.1 CO45XL FEATURES

- **SPACE HEATING LOOP** – Space Heating is plumbed in a series loop as shown in figure 2-4 with the difference being that the XL heater has most of the components built into a single enclosure. Included is an automatic summer/winter solenoid, which is always in the summer loop position. When any space heating thermostats call for heat, the solenoid automatically switches to the winter loop. The built in circulation pump is a March 809 magnetic drive delivering 3 GPM @ 12 foot head. When plugged into AC power, the electric heaters will supply part of the heat required for the system.
- **DOMESTIC WATER LOOP** – The system includes a 316 stainless steel flat plate heat exchanger, UL and CSA certified for use with potable water and an adjustable anti-scald mixing valve to regulate outlet water temperatures. This combination will produce continuous hot water at approximately 105 degrees F at a flow rate of 1.5 GPM. Hot water is available immediately when the system is up to temperature. The control system for hot water is completely automatic and includes a re-circulation function that keeps the system up to temperature even when no hot water is being used. It takes approximately 3.5 minutes for the system to begin producing hot water from a cold (system off) start. When plugged into AC power, the electric heater will supply part of the heat required for this system.
- **ENGINE LOOP** – The system has 316 stainless steel flat plate heat exchanger that interfaces the engine cooling system with the heater circulation system. If there is sufficient waste heat from the engine available, this feature can be used to heat the space when the engine is running. The engine preheat function uses a pump, which is mounted inside the case, on the engine loop side of the heat exchanger to use furnace heat to pre-heat the engine. The blue/black wire powering the pump runs back to the control box and must be field wired to your choice of a controller.

**9.2 CO45XL TECHNICAL SPECIFICATIONS**

Weight	108 pounds complete including circuit board
Size	10" High 15" Width 28.50" Deep
Materials	Case is Stainless Steel, Water jacket is Copper, Combustion Tube is Stainless Steel
Ratings	48,000 BTU Input
Flow	3.0 GPM minimum
Fuel	Diesel, Kerosene, Stove Oil, Winter Diesel
Fittings	All 1/2" NPT female. Brass
Circ. Pump	March 809 HS Custom Magnetic Drive, 12 VDC, 3.0 GPM @ 12" Head
Pre-Heat Pump	March magnetic drive
Potable Water	106 Degree F. Continuous Temp. @ 1.5 GPM Flow. Stainless Steel Flat Plate Heat Exchanger Rated UL and CSA for potable water
Engine PreHeat	Stainless Steel Flat Plate Heat Exchanger
Boiler Capacity	1.5 gallons
Heating Fluid	Propylene Glycol Anti-Freeze 50/50 Mix
DC Electrical	Furnace burner components are 12VDC. Total DC draw for all furnace components is 13 amps. Typical air handler draws 1 amp and a typical system uses 6 air handlers for a total system potential draw of 19 amps. The <i>HURRICANE</i> furnace is a cycling system and all components are not on continuously during a typical heated hour. Actual heated hour system draw is approximately 8 amps/hour. Minimum wiring sizes are;  Main system power: AWG 8, 25 amp fuse  Thermostats: AWG 16  Air Handlers: AWG 14
AC Electrical	The system uses two, 2 thousand watt heat clamps. Total AC Amp draw is 34 amps @ 120 VAC. Two separate circuits are provided, each drawing 17 amps. Circuits should be wired to separate switches. Breaker size 20 amps/each
Plumbing	System can be plumbed using heater hose, minimum ID 3/4" or PEX tubing minimum ID 5/8"

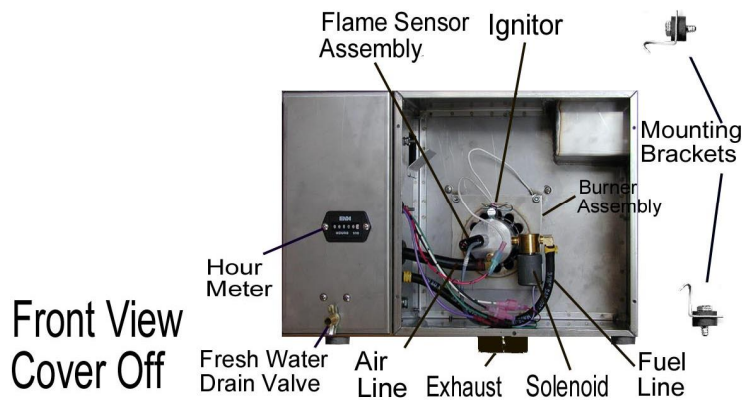
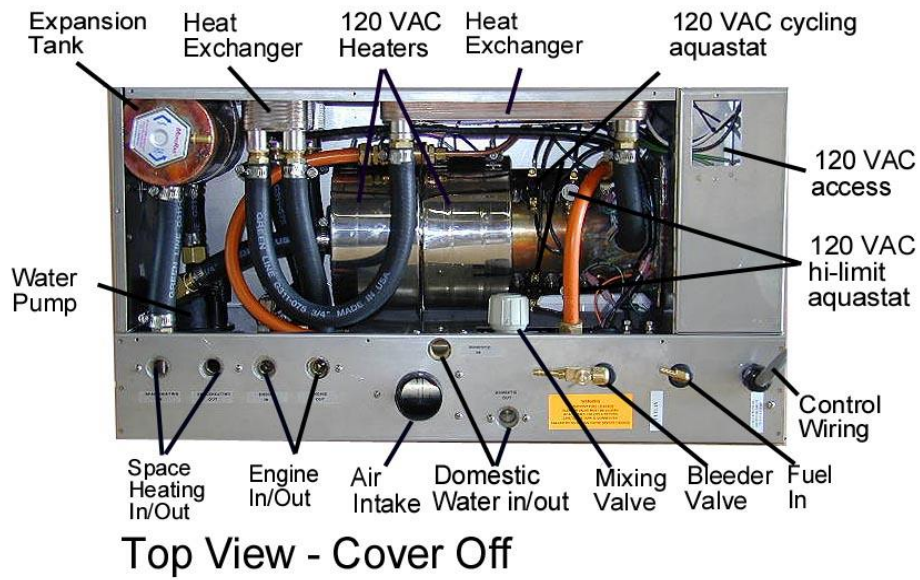
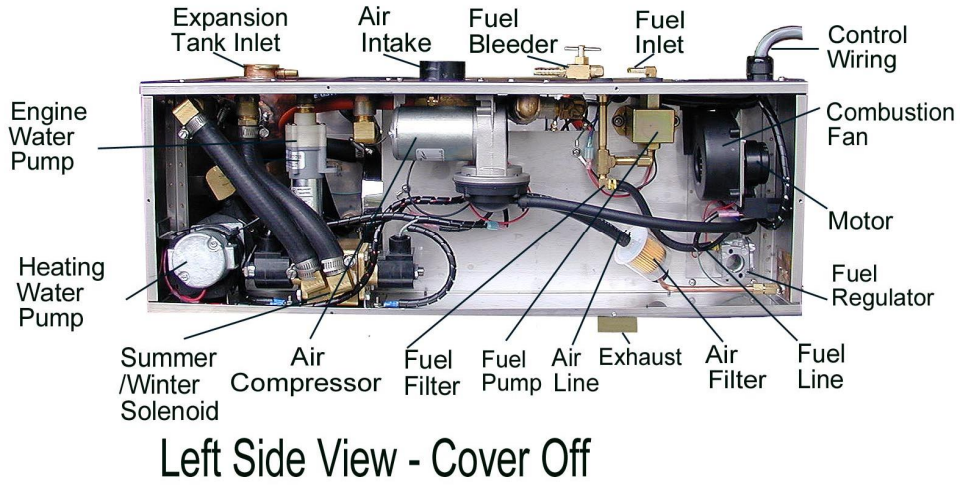

Figure 9-1  
CO45XL  
Components Parts

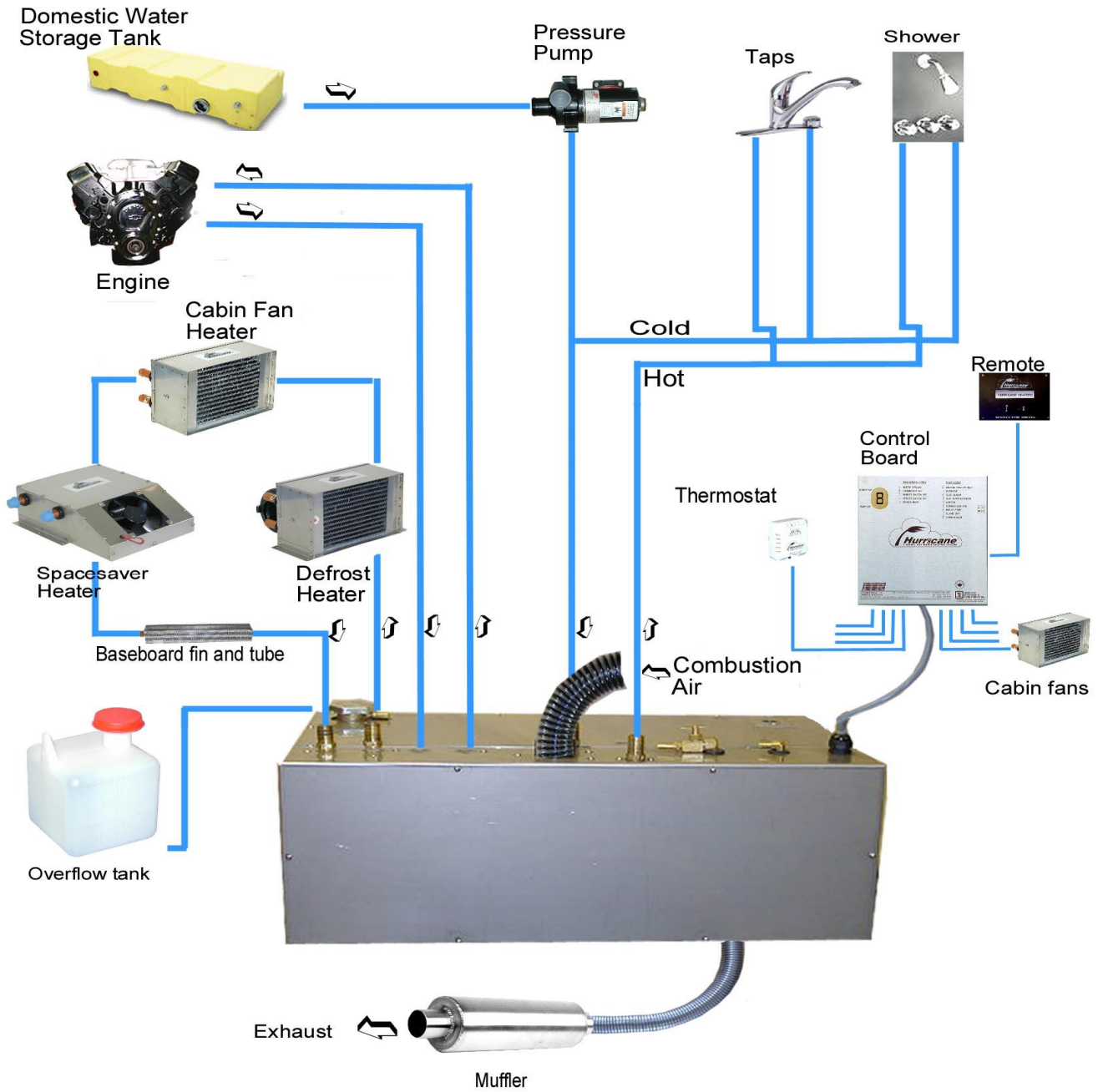

Figure 9-2  
Typical Installation CO45XL Heater

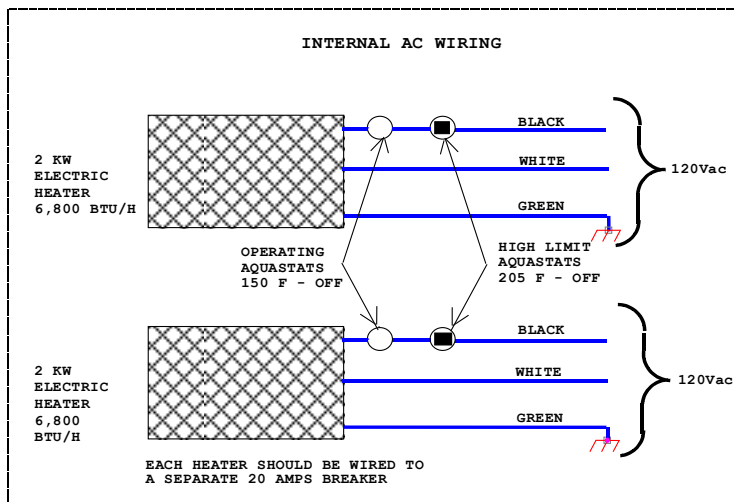
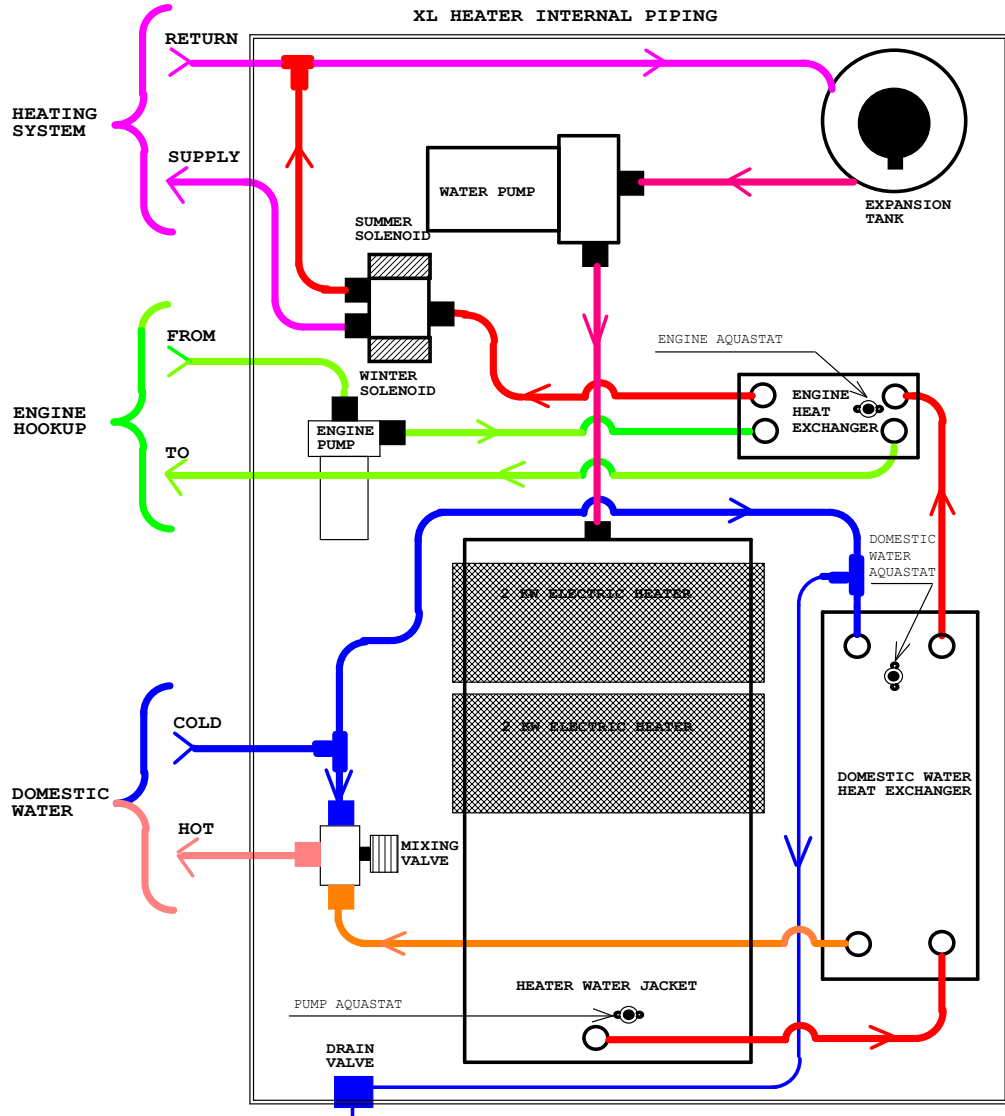

Figure 9-3  
CO45XL Internal Layout

### 9.3 CO45XL ELECTRICAL SYSTEM

Your CO45XL Heater and electrical control board are tested and operated together prior to shipping. Refer to figure 9-4, page 9-7 to see how the system is prewired.

Note: XL heaters manufactured after October 2003 utilize electrical schematic B00117 shown. For XL heaters manufactured prior to this date, please contact ITR for the appropriate electrical schematic. The first segment of the heater serial number found on the heater body identifies the heater model and manufactured date. I.E. CO45D0803 denotes a model CO45D manufactured August 2003.

**NEVER shut off the power to the heater using an inline battery or master switch, or disconnect the battery when the heater is running. Doing so will severely damage the heater and not be covered under warranty**