



**INTERNATIONAL LTD  
THERMAL RESEARCH**



# Installation and Operating Manual

Diesel Hot Water Heating System for Yachts

Complies with ABYC A-7



Copyright © February 2011

## International Thermal Research

### IN CANADA:

2431 Simpson Road

Richmond, BC, Canada V6X 2R2

Tel: 1-800-755-1272 or 604-278-1272

Fax: 604-278-1274

Email: [info@itrheat.com](mailto:info@itrheat.com)

### IN THE UNITED STATES:

Suite B , 11915 NE 56<sup>th</sup> circle

Vancouver WA USA 98682

Tel: 1-800-993-4402 or 360-993-4877

Fax: 360-993-1105

*Website: <http://www.itrheat.com>* All rights reserved. No part of this manual may be reproduced or transmitted in any form by any means, electronic or mechanical, including photocopying and recording, information storage, retrieval, or transmission, without permission in writing from International Thermal Research

### Disclaimer:

Due to our commitment for quality and ongoing product improvement, ITR reserves the right to modify or change without notice, any materials, applications, equipment, accessories, and/or prices. All measurements and weights are approximate.

# Table of Contents

## Technical Specifications and Standards

### Dangers • Warnings • Cautions • Notices

<b>Section 1, Overview</b> .....	<b>1-1</b>
1.1 Unpacking the Heating System.....	1-2
1.2 Protect Your Warranty .....	1-2
1.3 Heater Features .....	1-3
1.4 Critical Factors.....	1-4
1.5 Equipment, Tools, and Skills .....	1-4
1.6 Testing and Inspection .....	1-6
<b>Section 2, Mounting the Heater Unit</b> .....	<b>2-1</b>
2.1 Before You Begin .....	2-1
2.2 Your Mounting Location.....	2-1
2.3 What NOT to Do.....	2-4
2.4 Procedure .....	2-4
<b>Section 3, Installing the Exhaust System</b> .....	<b>3-1</b>
3.1 Before You Begin .....	3-1
3.2 Mounting Location .....	3-1
Recommendations .....	3-2
What NOT to Do .....	3-4
3.3 Procedure .....	3-4
<b>Section 4, Installing the Fuel System</b> .....	<b>4-1</b>
4.1 Before You Begin .....	4-1
4.2 Fuel System Installation.....	4-1
Recommendations .....	4-1
4.3 What NOT to Do.....	4-2
4.4 Procedure .....	4-3
<b>Section 5, Installing Fan Heaters</b> .....	<b>5-1</b>
5.1 Before You Begin .....	5-1
5.2 Fan System Operation .....	5-1
Features.....	5-2
Four-Zone Heating System .....	5-3
Accessories and Components Needed .....	5-3
5.3 What NOT to Do.....	5-4
5.4 Mounting Locations.....	5-4
5.5 Procedure .....	5-5

<b>Section 6, Wiring the Electrical System</b> .....	<b>6-1</b>
6.1 Before You Begin .....	6-1
6.2 12 VDC .....	6-1
6.3 120 VAC (Optional) .....	6-2
6.4 Electrical Components .....	6-3
6.5 What NOT to Do .....	6-5
6.6 Procedure.....	6-6
<b>Section 7, Plumbing the System</b> .....	<b>7-1</b>
7.1 Before You Begin .....	7-1
7.2 Plumbing Components.....	7-1
7.3 What NOT to Do .....	7-3
7.4 Installation Procedure .....	7-3
<b>Section 8, Filling and Testing the Circulation System</b>	<b>8-1</b>
8.1 Before You Begin .....	8-1
8.2 What NOT To Do.....	8-1
8.3 Procedure for Diaphragm Pump Filling Method ..	8-2
8.4 Procedure for Manifold Method.....	8-3
8.5 Verifying the Flow Rate.....	8-8
<b>Section 9, Domestic Hot Water Heating</b> .....	<b>9-1</b>
9.1 Before You Begin .....	9-1
9.2 Domestic Hot Water System.....	9-1
9.3 Engine Waste Heat Function.....	9-3
9.4 Engine Pre-Heat Function.....	9-4
Procedure .....	9-5
<b>Section 10, Operation</b> .....	<b>10-1</b>
10.1 Starting the Heater .....	10-1
10.2 Signs of Normal Operation .....	10-1
10.3 Main Control Board Operation.....	10-2
10.4 Stopping the Heater.....	10-2
10.5 Using the Electric Heating Elements .....	10-3
10.6 Stopping the Heater.....	10-3
10.7 Resetting a Fault .....	10-3
10.8 Electrical Noise.....	10-3
<b>Section 11, Troubleshooting</b> .....	<b>11-1</b>
11.1 Overview.....	11-1
11.2 Power On .....	11-1
11.3 Burner On .....	11-1
11.4 Service Switch Off .....	11-2
11.5 Remote Switch Off.....	11-2
11.6 Heater Cycling .....	11-3

11.7	Thermostats Off .....	11-3
11.8	Voltage Low of High.....	11-4
11.9	Overheat .....	11-4
11.10	Fuse Blown.....	11-5
11.11	Fuel Pump/Solenoid .....	11-6
11.12	Ignitor .....	11-6
11.13	Combustion Fan .....	11-7
11.14	Water Pump .....	11-7
11.15	Flame Out .....	11-8
11.16	Compressor.....	11-9
11.17	Bypass Mode .....	11-10
11.18	Water Pump On .....	11-10
11.19	Test Points .....	11-10
11.20	LCD Readout Remote Panel .....	11-12
11.21	Flame Sensor Module.....	11-12
11.22	Reduced Output .....	11-12
11.23	Smokey, Smelly Exhaust .....	11-13
11.24	A Silent Killer.....	11-13

**Section 12, Maintenance..... 12-1**

12.1	The First Few Weeks .....	12-1
12.2	Adding Antifreeze .....	12-1
12.3	Marine Exhaust System.....	12-2
12.4	Nozzle .....	12-2
12.5	Fuel Lines and Filter .....	12-2
12.6	Combustion Chamber .....	12-3
12.7	Checking Hoses and Tubes .....	12-3
12.8	Electrical System.....	12-3
12.9	Recommended Spare Parts .....	12-3
12.10	Protecting Hydronic Heating Systems .....	12-5

**Section 13, Warranty and Service..... 13-1**

13.1	Warranty .....	13-1
13.2	Installations .....	13-1
13.3	Limited Warranty .....	13-2
13.4	Owner's Responsibility .....	13-2
13.5	Not Covered Under Warranty .....	13-3
13.6	Customer Service Calls .....	13-4
13.7	Returns .....	13-4
13.8	Telephone Service .....	13-5

**Inspection Checklist (including Test Points)**

**Warranty Information & Warranty Card**

## List of Figures

Figure 1-1	Heater Unit.....	1-1
Figure 1-2	Typical Series Plumbed Layout .....	1-7
Figure 2-1	Hurricane II Dimensions .....	2-3
Figure 2-2	Hurricane IIL Dimensions .....	2-3
Figure 2-3	Heater Mounting Brackets.....	2-5
Figure 3-1	The Exhaust Goose neck Configuration .....	3-5
Figure 4-1	Fuel Connection Schematic .....	4-3
Figure 5-1	Wiring the Fan’s Aquastat.....	5-2
Figure 5-2	Mounting a Spacesaver Fan .....	5-6
Figure 5-3	Installing a Relay for Additional Fan Amperage .....	5-7
Figure 6-1	Sample Wiring Diagram for Electrical Elements .....	6-3
Figure 6-3	Wiring for a Fan Speed Switch.....	6-8
Figure 6-4	Wiring Diagram V2001 .....	6-9
Figure 7-1	Three Approved Methods of Installing Heater Hose.....	7-4
Figure 7-2	Generic Series Plumbed System with Water Heater .....	7-5
Figure 7-3	Generic Manifold Plumbed System .....	7-6
Figure 8-1	Filling System with Fluid Using “Diaphragm Pump Filling Method” .....	8-3
Figure 8-2	Filling System with Fluid Using “Manifold System” .....	8-5
Figure 8-3	Flow Meter Inline with Circulation Loop.....	8-7
Figure 9-1	Generic Series Plumbed Hurricane®II Hydronic System and Components.....	9-2
Figure 9-2	Engine Pre-Heating Components and Connections.....	9-5
Figure 9-3	Engine Waste Heat Re-use / Engine Pre-Heat Schematic .....	9-6
Figure 12-1	Maintenance Schedule.....	12-1

# Overview

Thank you for purchasing International Thermal Research's **HURRICANE® SCH25** diesel hot water heating system.

This section describes features of the **HURRICANE® SCH25** heater and explains what to do when you first receive your heater. It also covers critical information you need to know before beginning the installation, including how to protect your warranty, and tools and equipment needed.

Several diagrams are included at the end of this section—including one of a typical installation (other configurations are possible), a schematic of the heater's internal layout, and others.

Some of the figures in this manual represent a typical installation, but other configurations or methods may be acceptable. If in doubt, obtain approval from ITR.



Figure 1-1 Hurricane SCH25 Heater Unit

## 1.1 Unpacking the Heating System

As soon as you receive your **HURRICANE® SCH25** heater:

- 1 Unpack it carefully.
- 2 Check each component against the provided parts list to ensure that you have everything and that all parts arrived undamaged.
- 3 If you discover any missing or defective parts, call ITR immediately.
- 4 If you are not installing the heater right away, secure all components so none will be misplaced.
- 5 **Before installing the heater, read the rest of *Section 1 - Overview* of this manual. It contains critical information for a proper installation.**

A properly designed and installed heating system is essential for several reasons:

- To ensure that you and/or your customers receive satisfactory results and enjoy a warm, comfortable environment
- To ensure a trouble-free installation, a successful inspection and testing process, and ease of future maintenance
- To protect your warranty

## 1.2 Protect Your Warranty

This document reflects approved installation techniques, methods, and materials, and applies only to ITR equipment. The heater is only guaranteed by ITR if the entire system has been installed according to the requirements and recommendations set out here.

### NOTICE

---

No warranty will be extended to improper installations. Use of any unapproved materials, equipment, or installation procedures will result in a voided warranty for the entire

heating system. ITR accepts no liability for any damage or loss of service resulting from unapproved modifications.

---

- Efficient
- Clean
- Quiet
- Compact
- Safe
- Rugged
- Reliable
- Economical

## 1.3 Heater Features

The **HURRICANE® SCH25** heater is a **hydronic** heating system that has many advantages compared to the older technology of forced-air systems. The hydronic system uses a solution of water and antifreeze to provide heating to fans in the interior space areas, as well as a continuous supply of domestic hot water for the sinks, shower, etc.

The heater runs on 12VDC power, using a diesel-fired burner to maintain the temperature of the heater fluid. The **HURRICANE® SCH25** heater also can use waste heat from an engine, using a heat exchanger. The addition of an optional secondary water pump will also allow pre-heating of the engine.

Other features of the heating system include:

- High-temperature stainless steel burner and jacket prevents premature warping or burnout
- Stainless steel water jacket for long life and durability
- Insulated enclosure retains heat and minimizes noise
- Easy to install, field serviceable, with hookups and connections easily accessible off the top of the heater
- Quiet operation and low power consumption
- Low-pressure fuel system with built-in fuel pump
- Fuel-efficient burner capable of burning a wide variety of diesel-based fuels
- Exhaust has minimal smoke or smell
- Fan assisted sealed combustion chamber is designed to use outside air
- Simple, low amperage draw ignition
- Return fuel line to eliminate air and prevents nuisance shutdowns

- Electronically-controlled system with:
  - Automatic safety shutdown
  - Manual reset aquastats and a thermal cutoff for overheat protection
  - LED display on the control panel for diagnostics
  - Patented, proprietary flame sensor
- Remote control panel with on/off reset button, LCD digital readout, and audible alarm
- Heating control for up to four separate space heating zones, each with its own optional thermostat
- A domestic water heating zone and an engine heating zone

## 1.4 Critical Factors

Pay attention to notices of "Danger" "Warning" "Caution" and "Notice" in this manual.

The key factors to keep in mind when planning and carrying out the installation are:

- Mounting location restrictions for the heater, electrical control box, and exhaust outlet (to reduce noise, vibration, heat loss, etc.)
- Length, routing, and sizing of fluid lines, fuel lines, air flow tubing, exhaust piping, and wiring
- Unrestricted intake required to draw in outside air for combustion
- Ability to easily access and service the product, especially fuel, plumbing, and electrical systems
- After installation, requirement to purge water and fuel lines, establish flow rate, and inspect/test entire system using the ITR-supplied inspection check sheet

## 1.5 Equipment, Tools, and Skills

As the installer, you must be qualified and authorized to do the installation, which requires mechanical aptitude and electrical knowledge. Make sure you comply with existing ABYC industry practices, using the highest and most recent

standards and codes. Good workmanship is essential. Please refer back to *Section 1.1, Protect Your Warranty*.

You will need the following equipment and tools (not supplied) to install the heating system. This does not include optional equipment and accessories:

- Standard tools normally available in a well-equipped shop
- Approved fasteners for mounting the heater unit
- Stainless steel 1½" ID exhaust piping (depends on model); maximum 12' long with no bends (see *Section 3 – Installing the Exhaust System*, for details when bends are present).
- Thru hull exhaust for a marine installation
- ITR muffler
- Minimum ¼" supply and return fuel lines, approved rubber or copper
- Heater hose (to connect heater hose fittings to interior fans, and to connect heater to coach engine block); see the *Technical Specifications and Standards* for details
- Clamps to secure heater hose
- Expansion tank with a maximum 7Lbs radiator cap
- Overflow tank to connect to expansion tank, with clear plastic 3/8" hose; tank must be heavy-duty plastic, with a screw-down cap, and sturdy enough to mount firmly to a vertical surface
- Up to four thermostats (DC compatible) to allow temperature regulation of the four heating zones
- A self-priming pump and a 5-gallon fluid container to fill the system with fluid after installation
- Cabin fans or passive radiators for distributing heat to the living spaces

See **Figure 1-2**, for a typical series plumbed layout using the **Hurricane® SCH25** heater.

## 1.6 Testing and Inspection

After all components have been properly installed according to standard practices, ABYC standards, and the recommendations of this manual, the heating system should be test-operated for inspection purposes.

For your convenience, you can use the pullout *Inspection Check sheet* in this manual. The check sheet is divided into relevant stages, allowing each phase of the inspection to be carried out systematically, and then signed off by authorized persons.

**Figure 1-2: Typical Series Plumbed Layout**

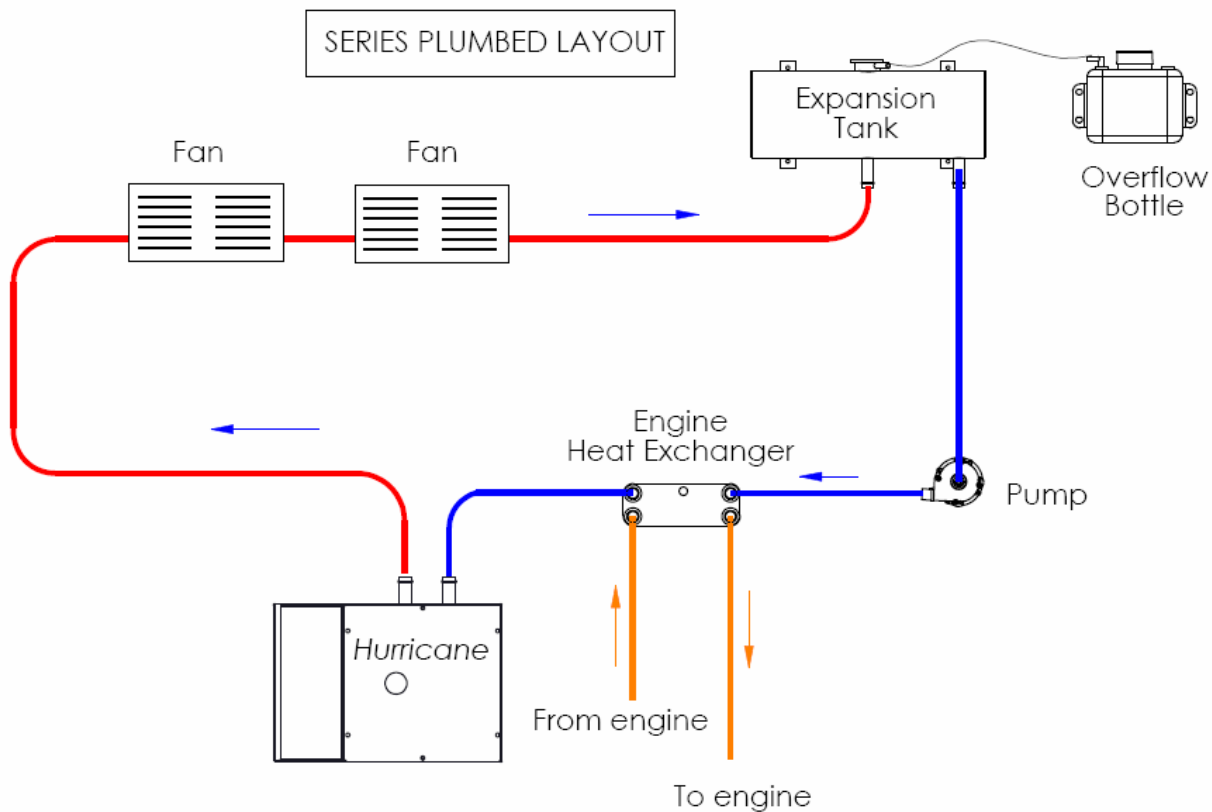

# Mounting the Heater Unit



## 2.1 Before You Begin

Plan the location of the heater and all its major components in advance to ensure the chosen locations are feasible and within the technical specifications.

Consider the following factors to help you decide exactly where best to mount the heating system:

- Heater weight when full
- Ventilation requirements
- Exhaust outlet location and maximum acceptable length
- Thru hull location and water line
- Potential for vibration and jarring
- Fuel storage location
- Most efficient plumbing runs
- Safe and convenient access for maintenance
- Number and location of interior fans
- Location of other equipment to be installed or connected to heater, including control box, heat exchangers, overflow tank, domestic hot water heater, batteries, etc.

### ! WARNING

---

Make sure you are familiar with *Section 1, Overview* of this manual. If the system is not installed according to specifications and with the correct equipment, your heater may not operate properly, safety may be compromised, and your warranty may be voided.

---



## 2.2 Your Mounting Location

Your mounting location should take into account:

- Mounting location must be able to support double the gross weight of the heater when full (i.e. 95 lbs. x 2 = 190 lbs/86.4 KG ) and must be of a non-combustible material.

- The HURRICANE® SCH25 model is 9"H x 13"W x 19"D (22.8 cm x 33.0 cm x 48.2 cm). See *Figure 2-1: Dimensions H2*

**! DANGER**

**The HURRICANE® SCH25 heater must not be installed in any compartment with flammable gases.**

- The HURRICANE® SCH25 heater must be completely isolated from living spaces. Combustion air must be drawn from an outside source and cannot contain any combustible gases.
- The heater must be mounted in an area that provides unrestricted access to the front panel and left-side panel, and access to top mounted fuel and water connections, power and exhaust connection (minimum of 10" top clearance – top exhaust version) and 1" clearance to all other HURRICANE® SCH25 surfaces.
- The heater must not be installed in any compartment with flammable gases.
- The heater must be mounted horizontal and level using four (4) ¼" through bolts and 1" diameter fender washers, lock washers and nuts.

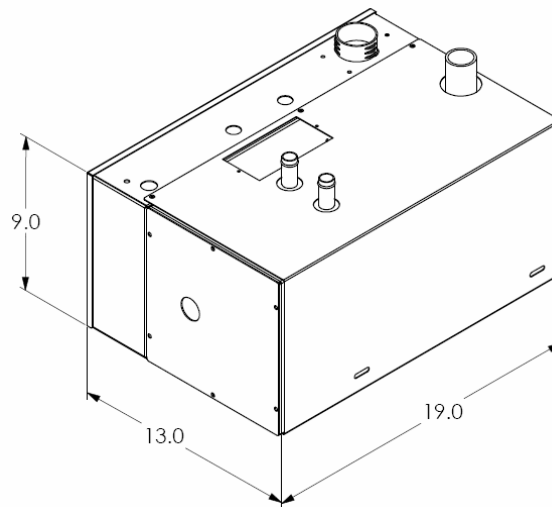

**Figure 2-1: Hurricane SCH25 Dimensions**

## WARNING

---

If The HURRICANE® SCH25 is going to be mounted in the engine compartment, check for adequate ventilation. When the engine is running, this area could be under a negative pressure. Make sure the air intake and exhaust hoses have no leaks and are well-fastened to the heater, muffler and thru hull fitting. Assembly parts that may cause injury through accidental contact should be protected.

Isolate the unit in the closed compartment so that no exhaust from the heater will infiltrate the living areas.

---

- Choose a sturdy surface in a location that won't be unduly affected by vibration and the jarring of rough roads or rough seas.
- Mount the unit with the front panel facing out and accessible. Facing out simplifies installation and maintenance.
- Open access is required to properly service the heater. Leave room at the **front, left-side** and **top** of the unit.
- Ensure that the exhaust tubing can be properly and safely routed to the outside. The maximum exhaust run for the system is 12'.



### 2.3 What NOT to Do

**Don't** mount the heater unit directly underneath the sleeping area. The sound of the heater cycling on and off may disturb light sleepers.



### 2.4 Procedure

After choosing the mounting location for the heater unit:

- 1 Mount the unit horizontally and level.
- 2 Secure the heater in place (against the wall, floor, or a mounting platform) using four (4) 1/4" through bolts using 1" diameter fender washers, lock washers and nuts. (See Figures 2-2).

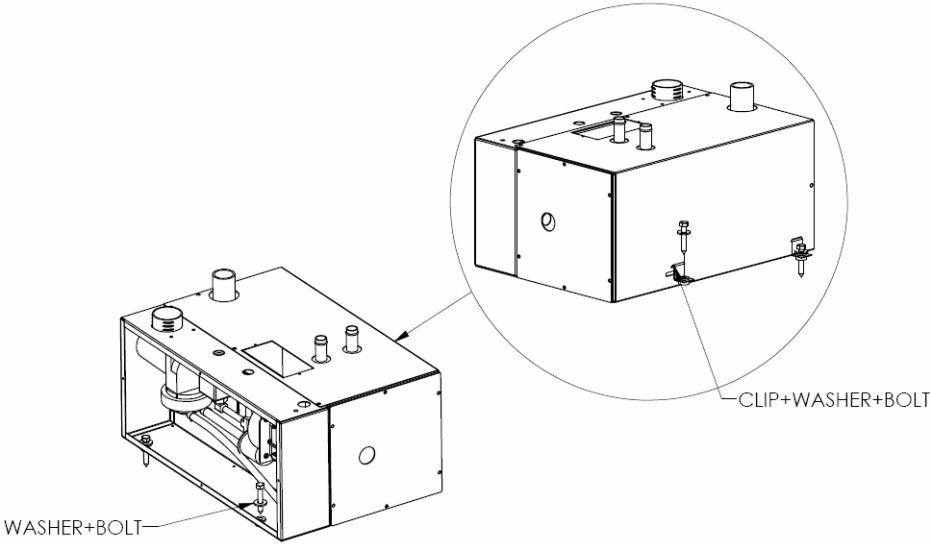

**Figure 2-2: Heater Mounting Brackets**

# Installing the Exhaust System



## 3.1 Before You Begin

For efficient and safe operation of the *Hurricane® SCH25* heating system, follow all recommendations for properly installing the exhaust. Any deviations from these must be approved in advance by ITR.

**! DANGER**

---

Although the heater's exhaust produces very low carbon monoxide emissions, caution is mandatory:

- Do not operate the heater in an enclosed area unless there is adequate ventilation.
- Isolate the heater unit in a closed compartment so that no exhaust from the unit will infiltrate the living areas.

Never place any exhaust parts close to combustible material or through a combustible wall or ceiling without fire protection. The exhaust can reach high temperatures. The products of combustion shall be ducted to the outside of the yacht or vehicle. Do not evacuate the products underneath the vehicle.

---

## 3.2 Mounting Location

**If you can't meet the technical specifications for mounting the exhaust, don't use this heater. The unit may perform poorly or become damaged if not installed according to specifications.**



### Recommended Exhaust Outlet Locations

The exhaust of the heater must always exit **outside of the yacht**, not inside the heater compartment. Otherwise,

exhaust fumes could infiltrate the yacht from the heater compartment.

Exhaust outlets shall:

- Be positioned so that wind turbulence will not affect proper operation
- Not be fitted within 12 inches (300 mm.) of a ventilator for the living area or an opening part of a window

Where the exhaust outlet is positioned vertically below an opening part of a window, the heater shall be equipped with an automatic shut off device to prevent operation when the window is open.

In a yacht installation, the following is recommended for the exhaust outlet location:

- Make sure that the thru hull is at least 30" above the water line with a goose neck rise on the exhaust to prevent water from getting to the heater through the exhaust. If the dual exhaust air-intake thru hull is used, ensure that the air-intake is placed between 10 o'clock and 2 o'clock and also goose-necked to avoid water ingestion, see Figure 3-1.
- There needs to be a 1/8" air gap around the exhaust thru hull. The standard thru hull is 3" in diameter. The hole for the fitting should be 3-1/4". Make sure that the holes for the mounting screws have enough material left to properly bite. The fitting must be centered in the hole.



### Recommendation for Installation

- You may use sweep bends but each 90° 2" radius bend is equivalent to 1.5 feet of exhaust piping. The maximum recommended straight exhaust pipe length is 12' including one 90° bend. For additional bends, subtract 1.5 feet per bend. Do not exceed these recommendations.
- Combustion air must be drawn from outside the yacht.

### Section 3, Installing the Exhaust System

- Use an ITR-manufactured muffler; no other muffler is acceptable.
- Exhaust outlet is on the top of the heater, towards the back.

**! DANGER**

---

**The exhaust and outlet are HOT and the surrounding areas must be thermally shielded and protected from the hot surfaces and heat build-up by insulation. Nothing can come into contact with any part of the exhaust system**

---

- Exhaust pipe must have a minimum of 3" (7.6 cm) clearance from all surfaces.
- Ensure that the exhaust cannot be plugged or restricted.
- The exhaust fitting on the SCH25 heater is 1.5" O.D. and the exhaust pipe used must have a minimum of 1.5" I.D throughout its length.
- All exhaust elbows must be of a large radius design (minimum radius 2.0").
- The exhaust must be supported a minimum of every 3' of its installed length.
- The exhaust pipe and the heater exhaust fitting point must use appropriate clamps and sealing compound, being careful not to get any compound on the inside of tube. Ensure that the connections are tight and leak free. The heater exhaust outlet pipe and the exhaust pipe itself must not be distorted or damaged during this process.
- When the heater is running, the connection points and the system must be checked for leaks and any found must be corrected. Periodically, check the exhaust fittings, connections, exhaust tube and insulation for leaks and integrity and correct if required.
- Appropriate exhaust insulation must be used to cover the entire length of any interior exhaust run.

- Solid stainless steel exhaust tubing is recommended but an approved stainless steel flexible exhaust tubing can be used. If flexible exhaust tubing is used, the exhaust tubing must be inspected regularly for leaks and deterioration as this type of exhaust does not have the life expectancy of solid tubing. Stepped band clamps are recommended for joining flex and solid tubing as they apply firm, even pressure.



### What NOT to Do

**Don't** use mufflers with any flow restrictions. Use ITR mufflers only.

**Don't** over tighten exhaust clamps or you may crush the heater's fitting.



## 3.3 Procedure

Figure 3-1 shows a standard setup for the exhaust with a gooseneck configuration. To install the exhaust system:

- 1 Leave suitable air spacing to protect combustible materials; use an exhaust collar and metal shields where required.
- 2 Securely seal the exhaust piping to the heater fitting using an approved exhaust clamp. If exhaust cement is used, care must be taken to ensure no cement enters the interior of the exhaust pipe or heater fitting, otherwise the exhaust flow will be impeded and the heater operation compromised.
- 3 Connect the exhaust piping in series with the muffler, using heavy-duty exhaust clamps. If you use vibration isolation mounts, they must be high temperature.
- 4 Connect the air intake tubing (2" ID) to the air intake fitting on top of the heater, and to an outside air intake fitting or dual thru hull (outside air only). Ensure the run of tubing is as short as possible to facilitate air flow.
- 5 Secure both ends of the air intake tubing with properly sized hose clamps to prevent air leaks.

### Section 3, Installing the Exhaust System

- 6 Make sure the air intake and exhaust hoses have no leaks and are not touching each other.
- 7 On a yacht, make sure the thru hull is at least 30" above the waterline and the exhaust must be goose-necked (see Figure 3-1).

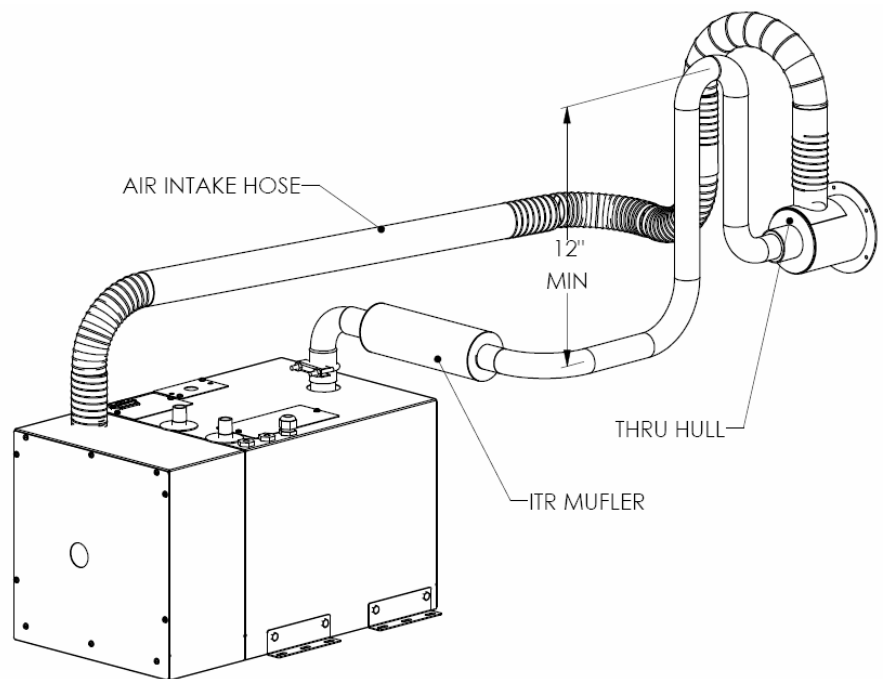

**Figure 3-1: The Exhaust Goose Neck Configuration**



# Installing the Fuel System

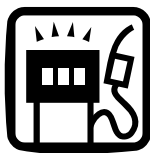

## 4.1 Before You Begin

For efficient and safe operation of the heater, follow all recommendations for properly installing the fuel system.

### ! DANGER

---

**Never use gasoline in the heater. Use only diesel fuel, furnace oil or stove oil.**

Keep fuel lines away from any heat source above 100°F (38°C).

Keep gasoline and any equipment that uses gasoline away from the heater location. The heater is not rated for use in an explosive environment.

### ! WARNING

---

Never share the fuel supply to the heater with any other fuel-burning device.

---

## 4.2 Fuel System Installation

### Recommendation for Installation

The heater's fuel connections are accessed from the top of the heater. The fuel inlet and fuel return are labelled and located on the top right panel of the heater and are not interchangeable. These fittings consist of 1/8" female NPT that connect to the fuel pump inside the unit.

The following is recommended for the fuel system installation:

**The fuel supply requires a dedicated pickup line from the main fuel tank.** The pickup must allow the heater to run out of fuel before the tank itself is empty.

- The fuel supply from the fuel storage tank to the fuel inlet must be from a dedicated fuel pickup.
- The fuel supply line must be of minimal ¼" ID.
- The fuel supply line should be installed with minimal rise from the fuel tank. In no event should the heater be more than 60" above the fuel tank.
- The fuel return line should be installed from the heater to the fuel tank.
- The fuel line must be run and secured so as to prevent damage, chafing and kinking during normal operation.
- The fuel line connection points and hoses must use suitable clamps and/or sealant and must be checked for leaks on the initial installation and also periodically as part of normal maintenance.
- A primary, UL and/or CSA approved fuel oil filter (not provided) must be installed inline in the fuel supply hose between the tank and the heater, in a manner that ensures easy access for maintenance.
- Fuel line hose used must be appropriate for your requirements. It is strongly recommended that the hoses have permanently installed end fittings.



### 4.3 What NOT to Do

- **Don't** allow the fuel or the fuel lines to become contaminated with foreign material.
- **Don't** allow the fuel lines to become damaged or constricted.

#### ! CAUTION

Ensure that fuel lines are always protected from contamination by foreign material. When installing or servicing, seal off ends to prevent contamination. After installing, you may also wish to flush the fuel line to rid it of air and any foreign material.

Be sure that all fuel lines are secured and will not become pinched, kinked or damaged during normal operation.



## 4.4 Procedure

To complete the fuel system installation:

1. Install the inline fuel filter. The optimal location is on a compartment wall next to the heater inline between the fuel tank and the heater.
2. Connect the fuel line to the dedicated fitting on the main diesel fuel tank.
3. Inspect the supply and return fuel line for any loose connections or damage. Fittings must be airtight.
4. If desired, install an inline shut-off valve on the tank side of the fuel filter to allow shutdown and filter service.
5. All fittings must be air tight and the lines purged of all air.

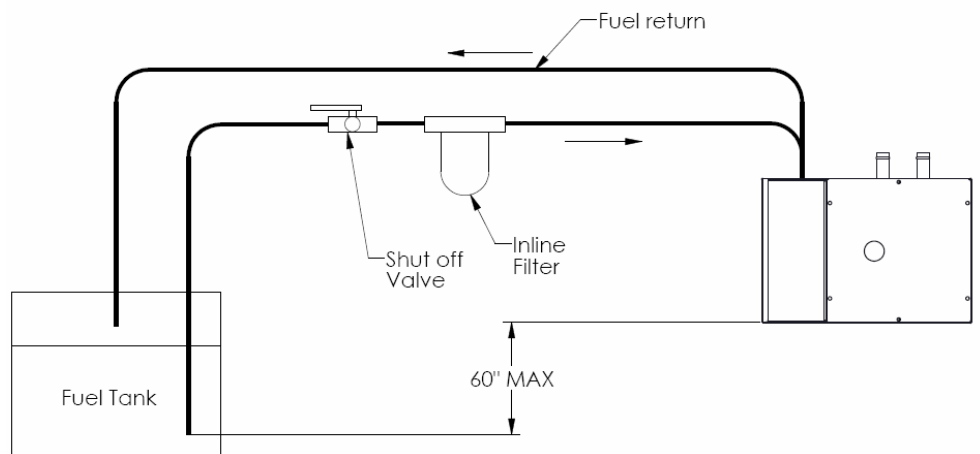

**Figure 4-1: Fuel connection schematic**



# Installing Fan Heaters



## 5.1 Before You Begin

ITR makes a variety of fan heaters that can be independently controlled by a thermostat. There are cabin heaters and Spacesaver heaters (where space is limited). These heaters draw as little as 0.9 amps and deliver 140 cfm. These heaters also come in high output versions and the above numbers are increased by 40%. They should be mounted as close to the floor as possible. They have a built-in aquastat which turns on the fan when the water running through it reaches 120°F (49°C).

The Defrost Heater provides up to 28,000 BTU/h and uses a three speed fan, 200/275/450 cfm, 40/55/100 watts.

**Note:** A limited number of fan heaters can be used with *HURRICANE® SCH25* heaters.

### NOTICE

---

Only the installation of ITR fan heaters is covered in this manual.

If you are installing non-ITR fan heaters, you must obtain prior approval from ITR. You must check the fans' total amperage draw to ensure they will be compatible with the zone controller, as well as flow capacity to ensure that each fan meets system requirements.

---

## 5.2 Fan System Operation

ITR fans consist of a 12VDC brushless fan and heater coil similar to a radiator.

When the heater unit comes on, the fan draws ambient air from the interior, blows it through the heater coil and back into the interior through a vent. There must be a return and output vent for each fan unit.

Features

ITR heater fans come with a built-in aquastat, which prevents fan operation until the system has reached minimum operating temperature. The aquastat can be deleted to meet particular installation requirements, but it is recommended that all systems be installed with the air fan aquastat.

Figure 5-1 shows how to wire up the aquastat in a fan.

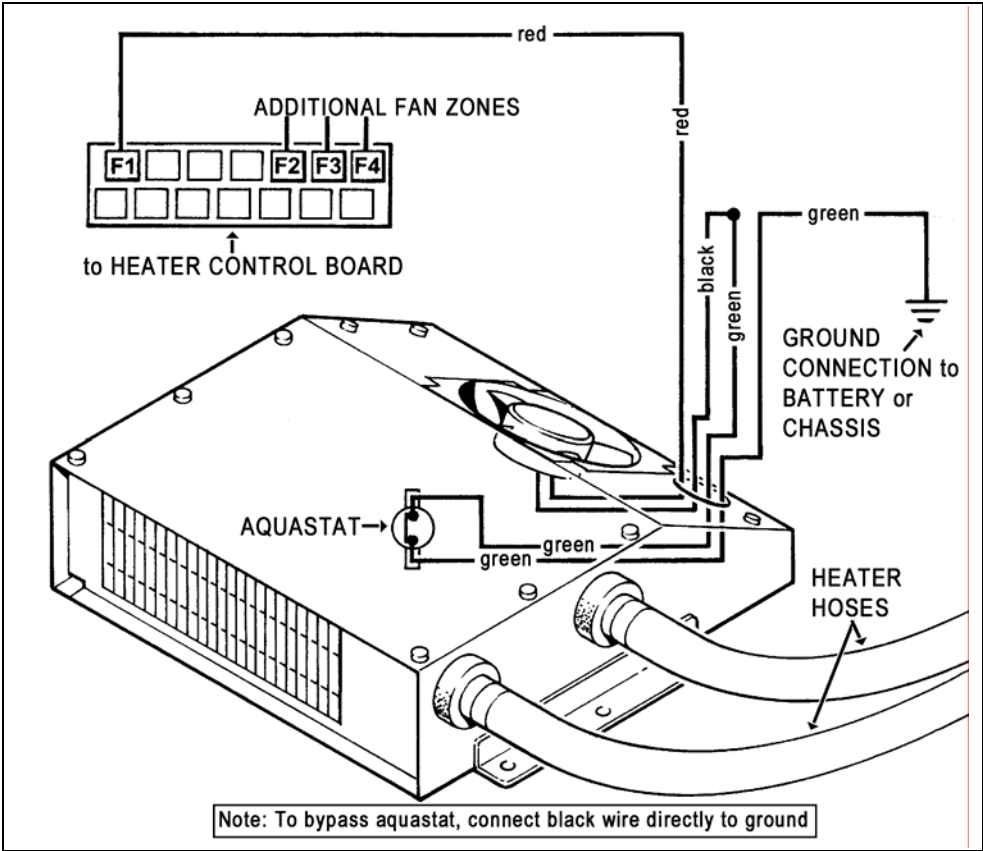

Figure 5-1: Wiring the Fan’s Aquastat

If a “passive” radiant heat system is desired (i.e., baseboard or fin and tube configurations), consult ITR for recommended

installation procedures and design. A different zone control system and additional equipment are required for a passive radiant heat system.

### Four-Zone Heating System

The Hurricane® SCH25 heater is capable of heating up to four different areas of the yacht using separately-controlled fans in a four-zone system.

Up to four thermostats (positive DC compatible) can be installed to allow temperature regulation of the four zones. The thermostats control both the fan heaters and the ITR heater itself. The accessory terminal block in the control board has a 10 amp draw limit for all the fans.

For higher BTU furnaces and larger installations an additional zone control board will give you the option of running an additional 4 thermostatically controlled zones for fan heaters.

### Accessories and Components Needed

In addition to the fans themselves, you will need at least some of the following accessories and equipment, which are not supplied:

- **Thermostats** — up to four thermostats can be installed in the interior.
- **Air Outlet Vents** — covers that are installed flush with the wall to vent heat for the installed heater unit.
- **Fan guards** — to protect the fan blades from damage, recommended for fans installed in storage areas or other accessible areas where something could contact the fans.
- **Screws** — #10 sheet metal screws or wood screws to mount the fan units. See *Figure 5-2, Mounting a Spacesaver Fan*.
- **Two-Speed Fan Switches** — to enable low and high-speed settings from inside the yacht; for use with the ITR cabin heater and Spacesaver fan.



- **Three-Speed Fan Switches** — to enable low, medium, and high-speed settings from inside the yacht; for use with the ITR defrost heater.
- **Air Ducting** — to allow you to install fans in a remote location (i.e. not directly adjacent to the interior space to be heated) and duct the heated air to its output location. Also, **air outlet plates** to allow you to install ducting for one, two or three separate outlets (e.g. you can use one fan to heat two different areas by installing a dual air outlet plate).



### 5.3 What NOT to Do

**Don't** install more fans that require more heat than a heater can produce, or a fan system that exceeds the total allowed draw of 10 amps. Your heating system will not run effectively. (If you choose to use a higher-draw fan motor, install a relay to handle the extra load; see Figure 5-3.)

**Don't** mount the return air outlet too close to the fan's air input source.



### 5.4 Mounting Locations

Carefully choose the mounting locations of your fans:

- Distribute the fans evenly throughout the yacht to ensure that all interior areas will be adequately heated.
- Typical locations are: bedroom, kitchen/hall, and living room. You can locate fans in storage areas or cabinets or behind walls.
- You should install one fan in the water storage area to protect the water and holding tanks from freezing.
- Provision must be made to protect water lines from freezing.
- Install fans at floor level or very near floor level, in order to optimize circulation.

ITR can suggest optimal fan locations if you provide a floor plan of your yacht or coach.

- Allow a minimum 16 square inch (100 cm sq) opening in the fan heaters' mounting compartments, to allow sufficient intake of air.



ITR's Spacesaver fan (pictured at left) has two stainless steel mounting brackets welded to the side of the case. It is designed to be mounted horizontally on a flat surface. This fan can also be ordered with a right- or left-hand hose configuration.



ITR's standard cabin heater fan comes with loose stainless steel brackets. The fan can be mounted on the floor or on the wall, either flat or on its side. The high output version of the standard cabin fan is pictured at left.

Thermostats should not be mounted on walls outside their respective zones because that could cause false temperature readings. Mount the thermostats on interior walls and bulkheads, away from windows and heater vents.



### 5.5 Procedure

After choosing the appropriate mounting locations and configurations:

- 1 Mount the fans using #10 sheet metal screws or wood screws.
- 2 If you are using ducting and a dual air outlet plate for any fan, limit the total length of duct for both outlets to 36" for optimum air output.
- 3 Select appropriate mounting locations for the thermostats, as well as any fan speed switches. You will wire these up to the control board in Section 6, *Wiring the Electrical System*.
- 4 If the system requires more than 1 amp per fan or a cumulative draw of more than 10 amps, install a separate relay to power the fans. This relay will use the existing fan circuit as a signal and must be wired to a secondary power source (not the heater's control board). See Figure 5-3.

- 5 To install plumbing lines to the fans, see Section 7, *Plumbing the System*.

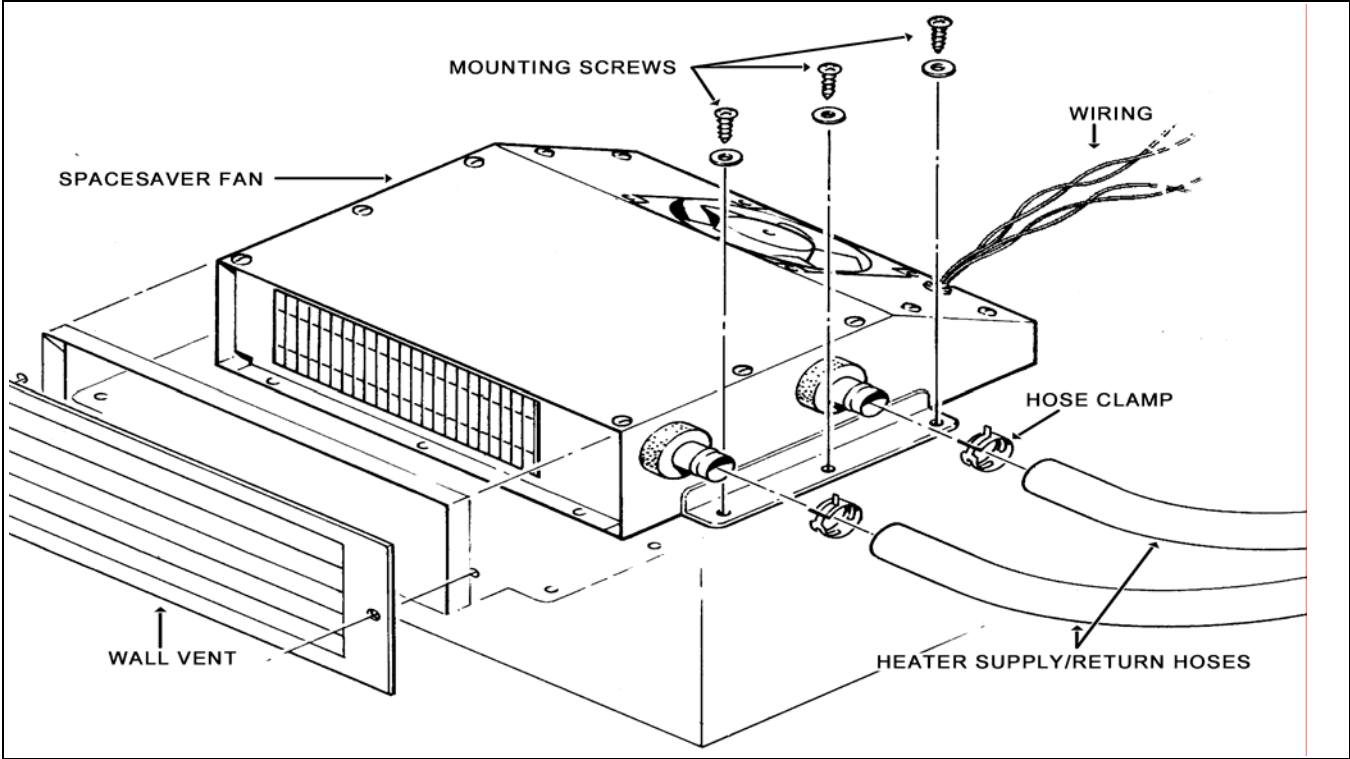

Figure 5-2: Mounting a Spacesaver Fan

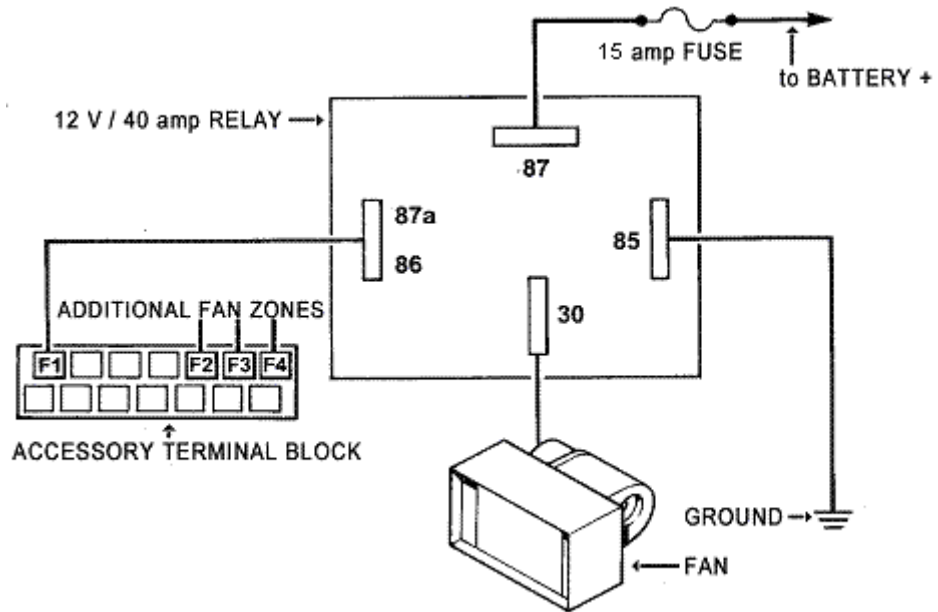

Figure 5-3: Installing a Relay for Additional Fan Amperage



# Wiring the Electrical System



## 6.1 Before You Begin

The heater and its electrical control board are pre-wired and have been thoroughly tested together as a unit.

To review the wiring system for the entire heating system, refer to the schematic at the end of this section, Figure 6-3.

### ! WARNING

---

All electrical connections and wiring must comply with normally-accepted 12 VDC wiring practices, local regulations, and ABYC standards. Only a qualified electrical installer should complete the wiring. All field wiring is to be in accordance with CSA Standard C22.1, Canadian Electrical Code Part I or the National Electric Code.

---

## 6.2 12 VDC

The following apply to the 12VDC power supplied to the heater:

- There is one electrical terminal on the main control board for the primary 12 VDC positive and negative (black) power. There are no direct 12 VDC power connections to the heater itself.

### ! WARNING

---

Primary DC power should originate from a dedicated connection on the house battery bank. A 25 amp fuse or breaker must be included inline from the battery to the positive connection on the control board. The primary power wire gauge must be sized to permit no more than a 3% voltage drop from the battery to the heater.

---

- There are no switches on the control board or box that disconnects the power to the heater and/or control board once 12 VDC power has been supplied to the board.
- A properly-shielded power system is required for safe, trouble-free operation.

---

---

## 6.4 Electrical Components



- **Control box and board** – The main control board is contained in a stainless steel control box (pictured at left) and is connected to the heater via a 10' long, ½" diameter interface cable.

All components in the heater unit are pre-wired to the main terminal block on the control board Figure 6-4 shows the connections

- **Fuses** – The control board contains four fuse holders with fuses pre-installed. These are standard, automotive, spade type fuses available from most auto parts stores.
- **Thermal Cutoff** - The heater burner box contains a non-resettable thermal cutoff that will provide protection against an overheat condition within the burner box. If activated, the thermal cutoff is designed to stop the fuel flow to the burner nozzle.
- **Accessory terminal block** – The following components need to be wired into the accessory terminal block on the control board:
  - Thermostats (up to four). Additional 4 zone board available for larger applications.
  - Fan heaters
  - Fan speed switches (if any)

- **Fault bypass and reset buttons** – These buttons allow testing of the heating system by bypassing the fault-sensing circuit. This fault bypass feature is engaged by depressing and holding the top button, depressing and releasing the bottom button, and then releasing the top button. To reset the heater, turn the heater service switch OFF, then ON again.

## ! WARNING

---

Do not leave heater running unattended in bypass mode. Bypass mode runs for five (5) minutes.

---

- **Test points** – These points on the control board allow troubleshooting of the heating system. For detailed information on the use of each test point, see Section 11.
- **Diagnostic display** – This is an LED indicator for the diagnostics of the heater. It also has signal lights for the heater power and circulating pump.
- **Circulating pump jumper** – This jumper on the control board allows you to run the circulating pump and test the system circulation without turning the heater on.
- **Battery connector** – Connection points for the positive and negative power from the house battery to the heater.
- **Remote connector** – Connection point for the cable from the remote LCD panel.
- **Service switch** – The service switch allows full (service switch on) or partial (service switch off) operation of the functions of the heater control board. In the OFF position, it will only allow the circulating pump and cabin fan circuitry of the control board to run in response to both a thermostat calling for heat and an external heat source (engine) supplying adequate heat to the system. The operating circuitry of the burner in the heater itself is non-functional. In the ON position, all operations and features of the heater and control board are functional. In normal operation, the service switch is left ON.

NOTE: The service switch has an additional short circuit fault (# 3 – 4 – 5 – 6 – 8 ) reset function. This is performed by turning the service switch OFF, then ON.

- **Hour meter** – Located on the top of the heater unit, the hour meter counts the accumulated operating hours for the heater.

Remote LCD panel – This panel enables the diesel burner and allows operational control and fault reset from inside the yacht. The panel also provides diagnostic information and a fault history. The panel connects to the control board via a supplied 25' RJ11 cable. A 50' cable is available as an option.



**NOTICE**

## 6.5 What NOT to Do

---

**Never** shut off the heater power via an inline battery or master switch while the system is running. Never disconnect the battery when the heater is running, and never disconnect the battery while the inverter is charging.

Doing either will severely damage the heater because it fails to automatically purge the combustion chamber. Such damage is detectable upon inspection and will *not* be covered under warranty. Always shut the system off using the normal system controls, after it has completed its purge.

When running in bypass mode, never leave the heater unattended.

---



## 6.6 Procedure

Consult the following table for required wire gauges and lengths. Consult Figures 6-3 to view how various components are connected.

### CONDUCTOR SIZES (GAUGE) FOR 3% DROP IN VOLTAGE

Length of Conductor from Source of Current To Device and Back To Source – Feet

	10	15	20	25	30	40	50	60	70	80	90	100
<u>AMPS</u>												
5 -	18	16	14	12	12	10	10	10	8	8	8	6
10 -	14	12	10	10	10	8	6	6	6	6	4	4
15 -	12	10	10	8	8	6	6	6	4	4	2	2
20 -	10	10	8	6	6	6	4	4	2	2	2	2

© American Boat and Yacht Council, Inc.

- 1 Mount the control box adjacent to and accessible to the heater unit. Mount it vertically, not horizontally. Do not mount it close to excessive heat.
- 2 Wire the positive terminal of the house battery through a 25 amp, heavy-duty rated fuse (using #10 gauge wire) to the positive terminal on the control board inside the main control box. Wire the negative terminal of the house battery to the negative terminal of the control board.
- 3 Using the recommended wire gauges, prepare all wire terminations for approved connections from the control board to each of the fan heaters and thermostats (and any optional switches).
- 4 Wire the fan heaters to the terminals in the control board using #16 wire (minimum) and a #8 fork connection on each fan. See Figure 6-4. There are four terminals, F1 to F4, corresponding to the four zones.
- 5 Connect the fan grounds to the negative terminal of the battery or to an adjacent chassis ground location.

## Section 6, Wiring the Electrical System

- 6** Wire the thermostats for the fan heaters to the terminals in the control board using #18 gauge wire (minimum) and a single #8 fork connection. See Figure 6-4 for the correct terminals (T1 to T4, and T-C common).
- 7** If domestic water heating, engine waste heat, or summer/winter loop functions of the heater are required, see Section 9 for details.
- 8** If installing any optional fan speed switches, wire them to the yacht's wiring system, not to the heater control board. Install the switch between the fan circuit and the positive DC fan connection using #16 wire (minimum) and a #8 fork connection. See Figure 6-3 for a switch wiring diagram.
- 9** Mount the remote panel in the living areas where it can be easily accessed. Any accessory switches should be mounted adjacent to the remote panel for ease of use.
- 10** Connect the remote cable from the control board to the remote panel.
- 11** Ensure that all pre-wired connections between the heater and control box are secure.

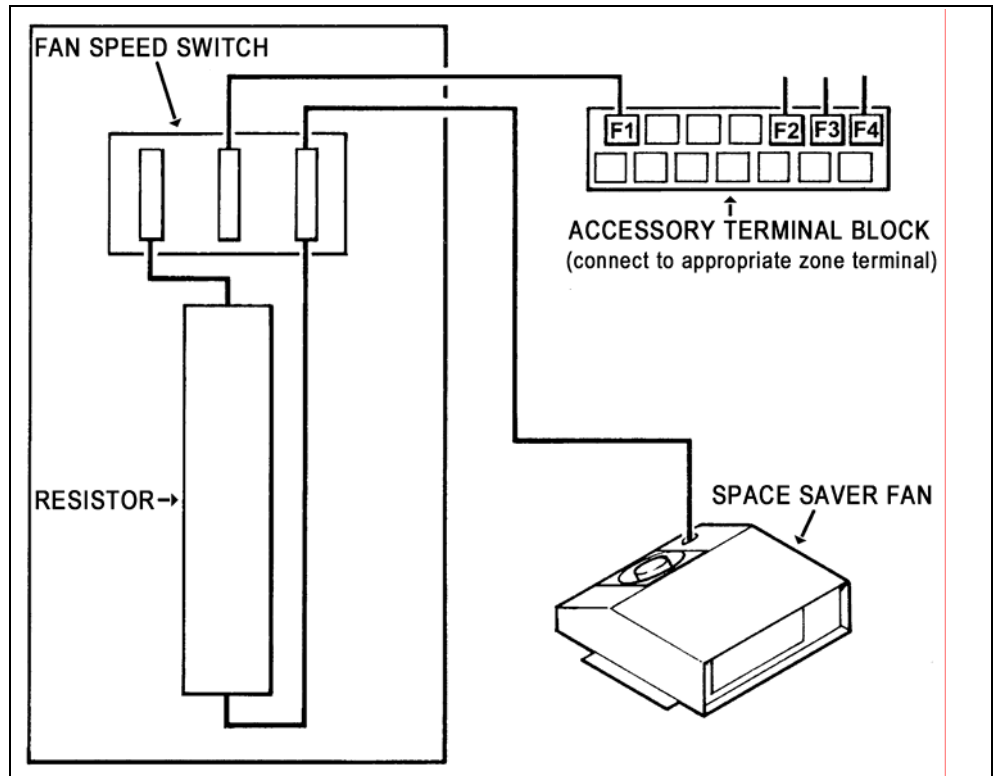
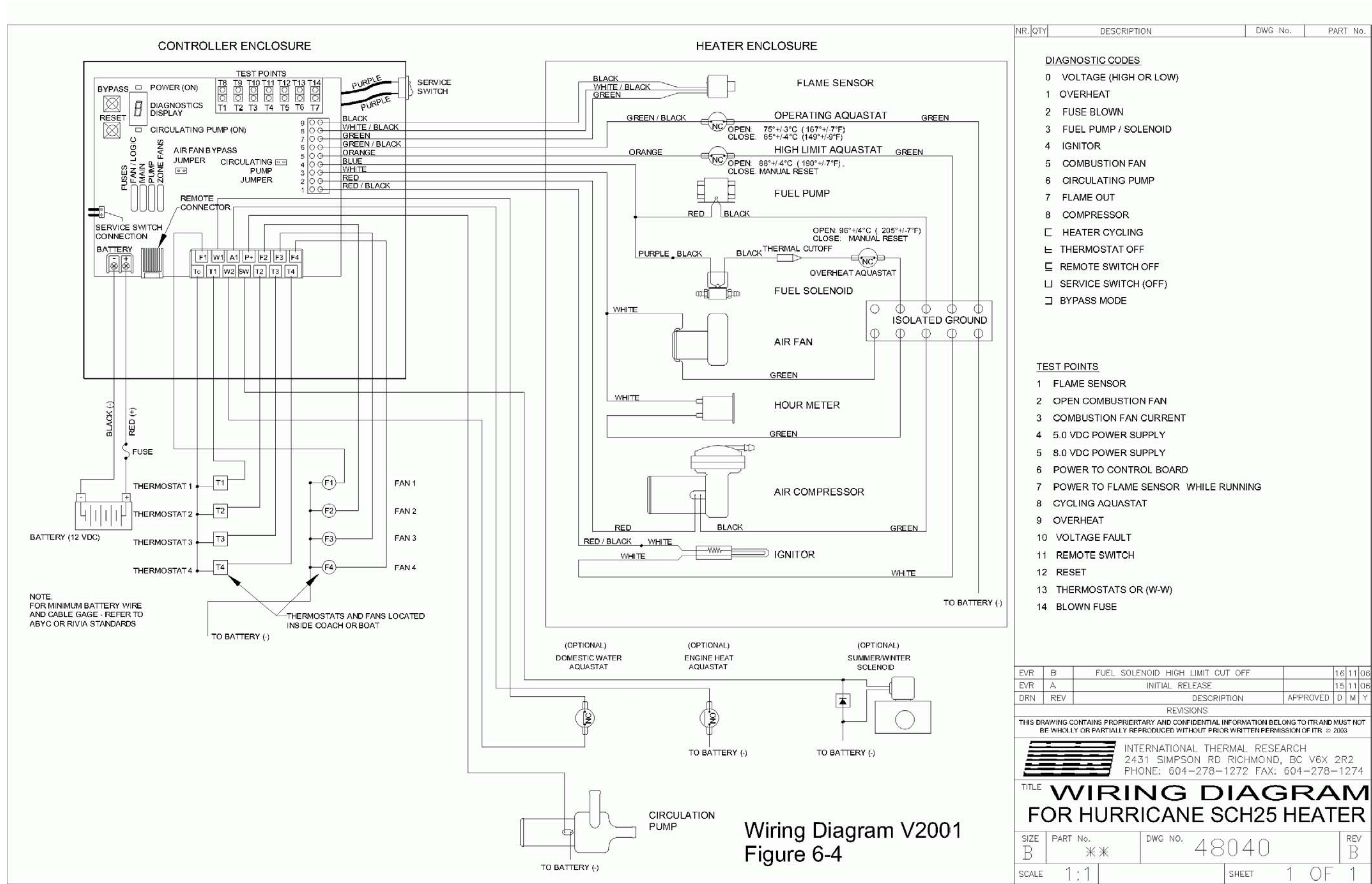
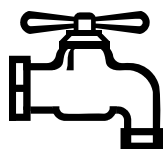

Figure 6-3: Wiring for a Fan Speed Switch



# Plumbing the System



## 7.1 Before You Begin

For an efficient heating system, you must:

- Achieve an optimum of **1 GPM per 10,000 BTU/h**
- Minimize heat loss from the heater hoses
- Eliminate air from the system

If you use more than the maximum number of cabin fan heaters to heat your boat (depending on the heater model), you may get poor results. Fans located directly after the heater will starve the system, not allowing heat to reach the fans downstream. A supply and return manifold each with 2 or 3 series loops should be used to more evenly distribute heat throughout.

## 7.2 Plumbing Components

**Circulating water pump** — Your heating system should be properly sized to circulate the water in your heating system.

A flow rate of 1 G.P.M. (gallon per minute) for every 10,000 Btu/h of heater capacity is recommended which will provide approximately 20°F temperature difference between the inlet and outlet of the heater. The slower the flow, the larger the temperature difference and the more time for heat transfer. The faster the liquid flows, the less temperature difference and the higher the resistance to the system. A pump must also have the capacity to flow the water through the resistance of a single heating loop consisting of all the pipe, fittings, boiler, heaters, etc., everything which makes up your heating system. On larger boats, a number of loops may be run off a common header in which case only the loop with the highest resistance should be used to size the pump. Each item has a pressure drop (psi.) across it and the total





pressure drop X 2.3 equals pressure head in feet. If a pressure gauge is used on the inlet and outlet of a pump, the difference in pressure (psi.) is the resistance. Using the head in feet and the flow in G.P.M., the manufacturer's flow charts will allow you to pick the right pump.



Ensure the pump is at a lower point than your *HURRICANE*® *SCH25* heater. Terminals are located inside the main control box which allows switching of pumps up to 10 amps maximum. Once the number and sizes of pumps are established, the total amperage will determine the size of wire and the fuse used in the main control board.



**Expansion tank** — It allows the circulating fluid to expand in conjunction with the overflow tank. Mount either the horizontal or vertical expansion tank at the highest point of the system and pipe to the inlet of the circulation pump. Use a 7 Lbs pressure radiator cap maximum.

**Never remove the expansion tank radiator cap when the system is hot and running. Scalding hot water may be forcefully expelled, seriously burning you. Only remove the cap when the system is cold.**

**Overflow tank** — allows you to monitor fluid levels and fill the system with fluid. An approved overflow tank (available from ITR, pictured at left) must be heavy-duty plastic. You must be able to mount it firmly to a vertical surface.

**TIP →**

Reduce heat loss as much as possible by insulating the hose where it may be exposed to outside air. However, when you run hose through closets, cupboards, and storage lockers, a little heat loss is desirable to reduce moisture in these areas.

**Heater hose** — use heavy-duty heater hose or PEX tubing. Slip-on foam insulation coverings may be used over the hose fittings to reduce heat loss. Secure all hose connections with spring clamps.

Note: If long hose runs or other restrictions reduce the fluid flow to less than the recommended flow, installing a second circulating pump is recommended.

**Air bleeder vents** — Air vents should be installed at strategic points along the water system's piping where air might accumulate. An inline bleed assembly (part # 2215), is available for placement anywhere you may be required to bleed air from the system.





**Shut-off valves** — Inline shutoff ball valves should be installed on either side of an item to isolate it so that it can be serviced or replaced without draining the system. When using a header and branching off with 2 or 3 loops, valves should be used at the start of each loop to balance the flow through each loop.



**NOTICE**

### 7.3 What NOT to Do

---

The heating system's circulating water pump is the most critical part of the heating system. **Never** let the pump run dry or you will damage the impeller. This is not covered under warranty.

**Don't** use low-quality heater hose.

**Don't** let the hose come into contact with solvents, which may cause it to soften and swell. If there is any risk that solvents may contact the hose, insert it into PVC plastic tubing for protection.

---



### 7.4 Installation Procedure

To install and connect the plumbing components and heater hose (see Figures 1-2 and 7-2 for typical plumbing diagrams):

- 1 Mount the overflow tank adjacent to the expansion tank at about the same level, in a location that allows fluid to be added to it easily.
- 2 Connect the overflow tank to the expansion tank inlet fitting using a clear plastic 3/8" hose (supplied with the ITR overflow tank). Secure both connections with a clamp.
- 3 Lay out the heater hose horizontally through the yacht, linking each fan in a series loop or manifold layout. Keep high points to a minimum.

- 4 Ensure there are no kinks or sharp bends that might restrict the fluid flow. If bends are required for PEX tubing, fit the tubing into a plastic bend support (available for 1/2", 5/8", and 3/4" tubing). Standard heater hose does not require bend supports.
- 5 At the heater, carefully connect the heater hose for the heater's plumbing system to the threaded inlet and outlet tubes on the heater, using appropriate fittings. See Figure 7-1.

## NOTICE

If you use too much force when connecting the heater hose to the fans, the ends may break and leak—this is not covered by warranty. To avoid breakage, apply a soapy lubricant to the air fan hose connections before attaching the hose.

- 6 At each fan, connect the other end of the hose or tubing to the inlet and outlet tubes.

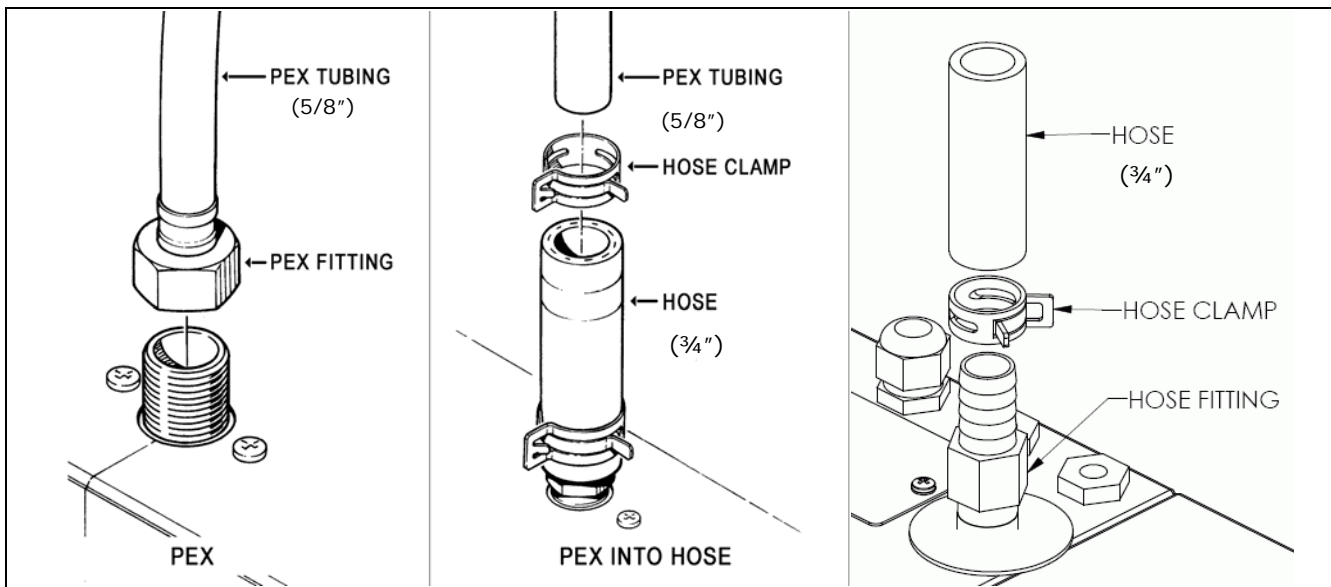

**Figure 7-1: Three Approved Methods of Installing Heater Hose  
(consult ITR for alternative methods and products)**

Section 7, Plumbing the System

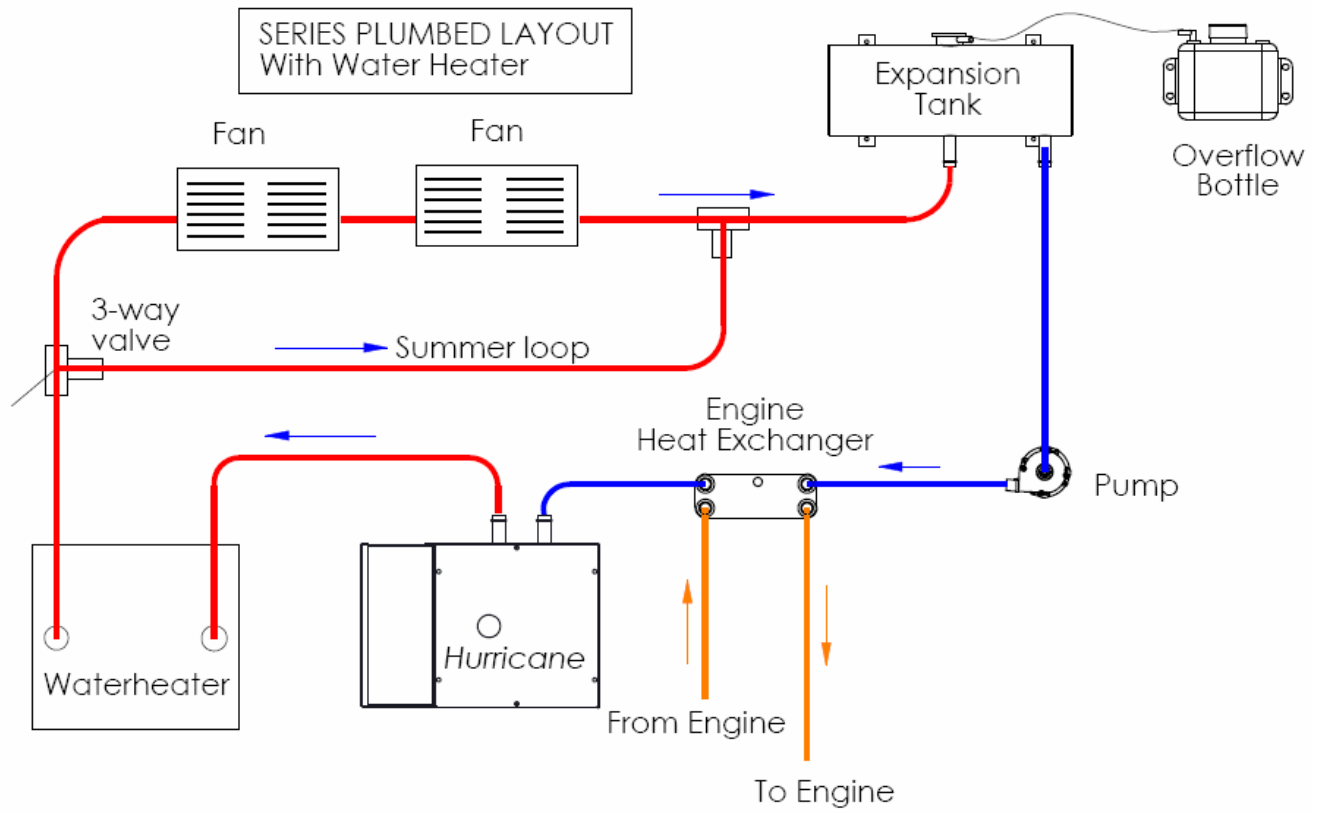

Figure 7-2: Generic Series Plumbed System with Water Heater

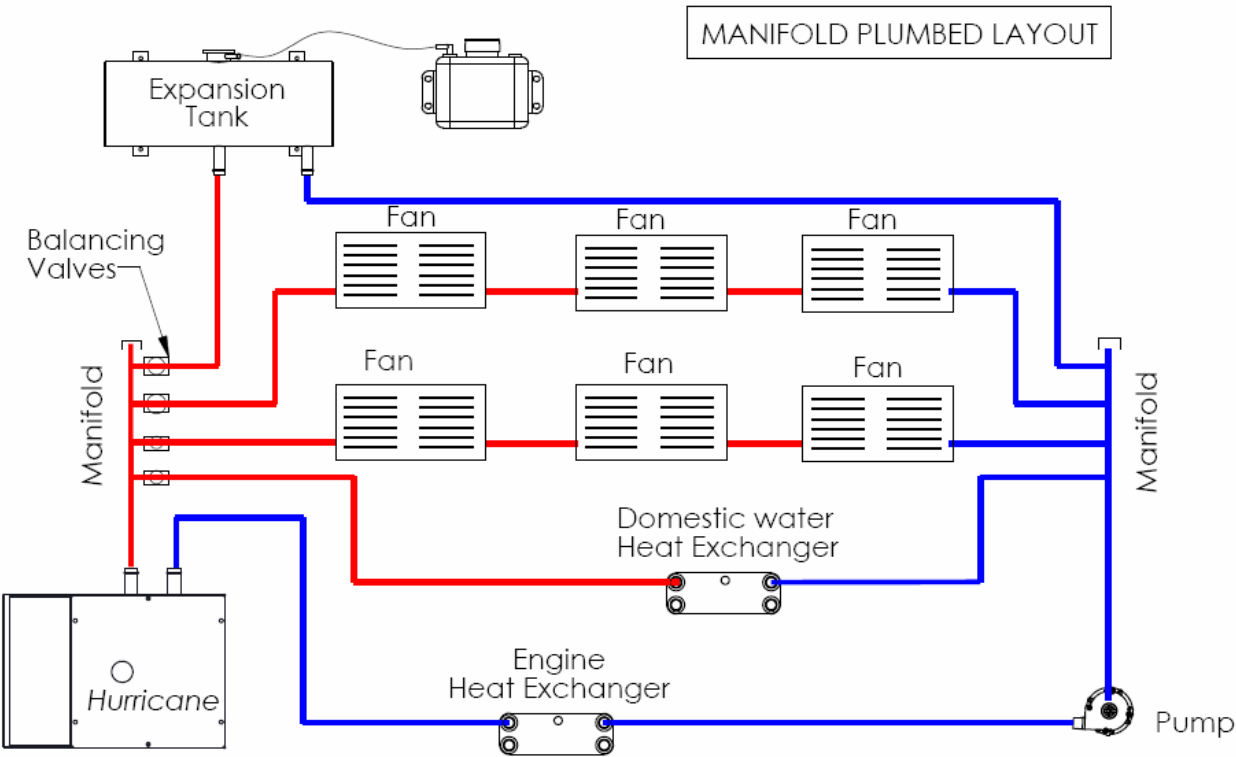

Figure 7-3: Generic Manifold Plumbed System.

# Filling and Testing the Circulation System

**TIP →**

If you fill the system with a 50/50 mix of antifreeze and water, this may save you from having to drain and refill the system.

However, if you are unsure of the installation, it's better to fill and test the system with water first.

## 8.1 Before You Begin

After the heating system has been installed, you are ready to fill the system with fluid for purging and testing purposes.

There are two recommended ways you can fill the heating system with fluid and purge it of air at the same time:

- Heater hose method
- Manifold method

These methods are described below. They are very similar, but the manifold method provides a permanent, built-in mechanism for filling and purging. For both methods, you will need a **separate self-priming pump**.

After the first 50 hours of operation, the yacht movement may cause more air bubbles to be dislodged. Monitor fluid levels carefully and add fluid if necessary.



## 8.2 What NOT To Do

**Don't** forget to remove the circulating pump jumper (see figure 6-4) after filling and purging. Otherwise, the pump will run continuously.

**Do not** attempt to purge the system without installing an expansion tank in the system. Do not bypass the expansion tank when purging the system. Failure to install the expansion tank or bypassing the expansion tank prior to purging the system will result in permanently damaging the heater

**NOTICE**

---

Although the system can operate on any standard automotive antifreeze, for safety reasons ITR strongly recommends that you use non-toxic antifreeze.

---

**NOTICE**

**Never** let the system run dry during filling and purging. Also, never operate the pump without any fluid in the system.

After purging, continue purging until you hear no bubbling or pump noise to ensure that all air has been removed from the system. Leaving air in the system can overheat and damage the unit if not fixed—such damage is not covered under warranty. Purge the system again to correct the problem. After 10 hours of system operation, check fluid levels.

**! DANGER**

---

**Never** remove the cap on the expansion tank when the system is hot and running. Scalding hot water may be forcefully expelled.

---

### 8.3 Procedure for Diaphragm Pump Filling Method



To fill, purge, and test the heater's circulation system using the diaphragm pump filling method, use the following diagram (Figure 8-1) and procedure. Do not use this method if you have installed PEX tubing at the heater connections—use the more reliable manifold method instead (see Procedure 8.5).

## Section 8, Filling and Testing the Circulation System

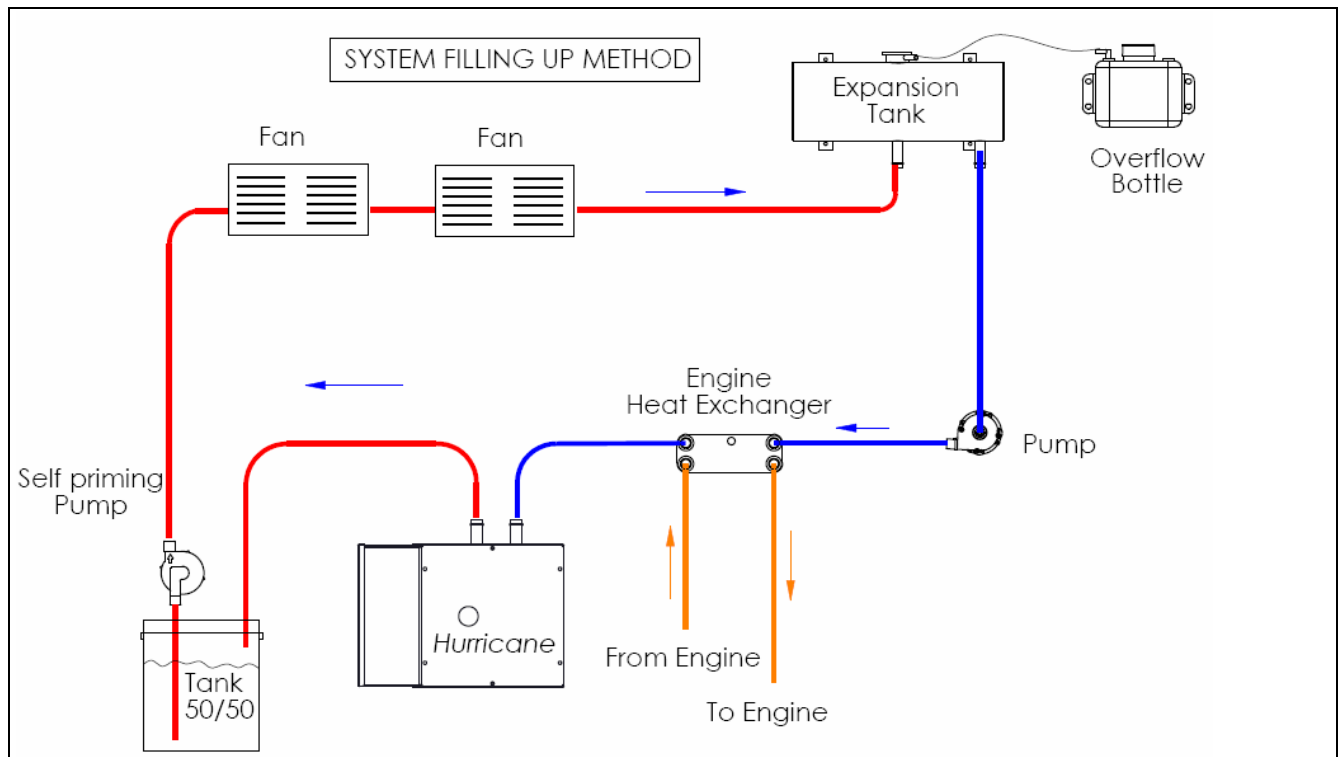

**Figure 8-1: Filling System with Fluid Using “Diaphragm Pump Filling Method”**

- 1 Disconnect one of the heater hoses. Preferably the outlet.
- 2 Connect this hose to the outlet of a self-priming pump (for example a diaphragm pump) and use a spare hose to go from the inlet of the pump into a 5-gallon tank of straight water or 50/50 mix (antifreeze and water) equipped with a mesh screen to capture any debris.
- 3 Use another spare hose to go from the heater into the tank. Secure to heater with hose clamps
- 4 Check to ensure any air vents and drains are sealed. Also check if the radiator cap on top of the expansion tank is on tight.
- 5 Start the self priming pump.
- 6 As the fluid is pumped out of the 50/50 tank, make sure that the supply pump never sucks air.

- 7 Slowly add more fluid to the tank until all air has been expelled and the mixture starts coming out of the return hose in the 50/50 tank. (Keep the fluid level in the tank above the inlet of the suction hose.) This will flush the system of any debris and purge the lines of air.
- 8 Monitor the heating system during filling and purging to ensure:
  - all fittings remain secure
  - no leaks in any connections or hosing
  - good flow through the expansion tank
  - No pressure build up in excess of 7 PSI.
- 9 If you discover any leaks, temporarily stop the filling procedure to repair the leak.
- 10 Continue running the self-priming pump for about 10 minutes *after* it has purged all air from the system, and continue monitoring for leaks.
- 11 If you filled the system with straight water, drain it and refill it with a 50/50 mix of antifreeze and water.
- 12 Stop the pump, pinch off the hose at the pump outlet and the other spare hose running into the tank.
- 13 Remove the spare hose from the heater and reconnect the original heater hose.
- 14 Check and fill the overflow tank with fluid to the correct level if necessary.
- 15 Turn on the heater's circulating pump by putting the pump jumper (see figure 6-2) and purge the system of any air.
- 16 Verify the flow rate with an inline flow meter if present.
- 17 Check that the circulating pump runs quietly and smoothly. If there is still bubbling or cavitation present, continue purging the system.
- 18 Double check the entire plumbing system for leaks. Open and close air vents (if present) to eliminate remaining air bubbles.
- 19 Recheck the fluid level and circulation in the expansion tank. Top up as necessary.

- 20 On the control board, remove the pump jumper. This returns the pump to normal operation.
- 21 The heater can now be started up.



## 8.4 Procedure for Manifold Method

This method involves permanently installing a priming manifold inline with the circulation loop, allowing the system to be purged and tested in the future (if desired). A priming manifold is available from ITR.

Use this method if you have installed PEX tubing for the heating system.

To fill, purge, and test the heater's circulation system using the manifold method, use this diagram and the following procedure:

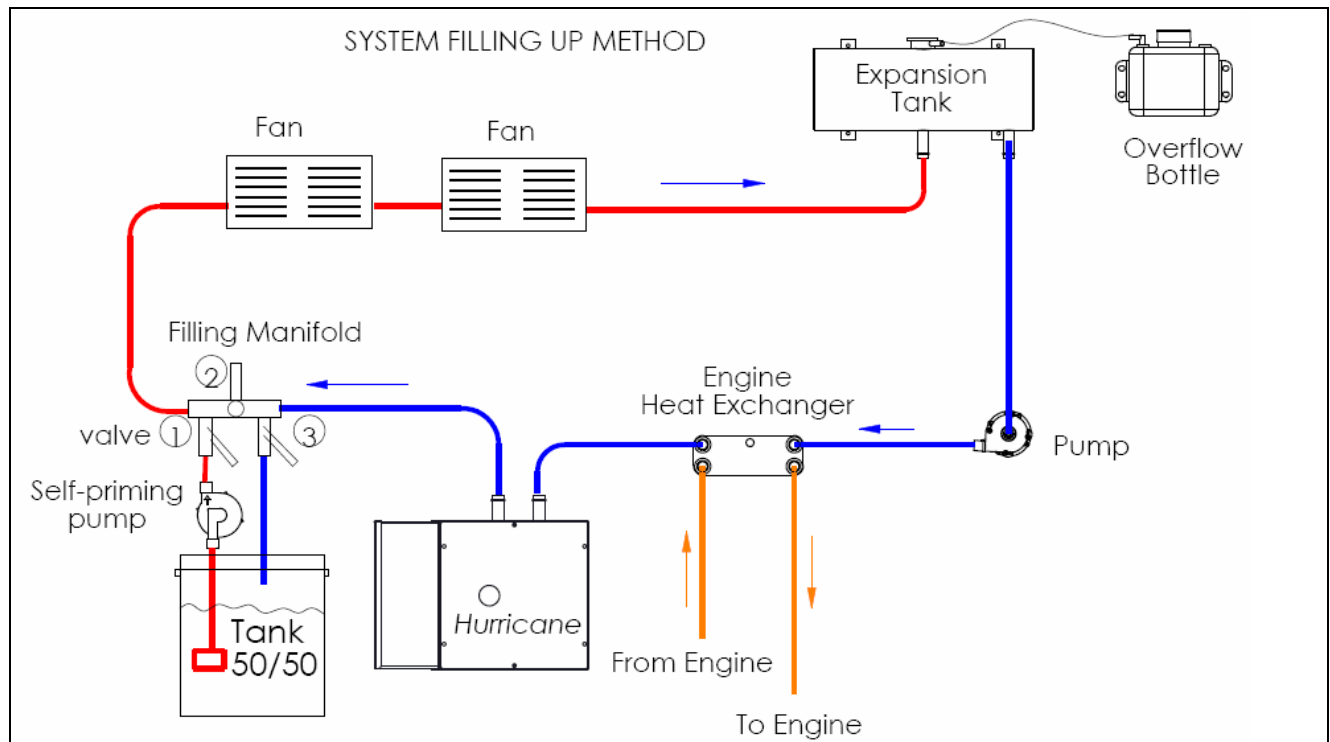

Figure 8-2: Filling System with Fluid Using "Manifold Method"

## Section 8, Filling and Testing the Circulation System

- 1** Put the pressure pump's suction hose into a 5-gallon tank of straight water or 50/50 mix (antifreeze and water), equipped with a mesh screen to capture any debris.
- 2** Attach the outlet of the self-priming pump to the manifold inlet and a spare hose from the tank to the manifold outlet. (see figure 8-2)
- 3** Close the middle valve (2) and open both in-outlet valves(1 & 3). This forces the fluid to circulate through the 50/50 tank
- 4** Check to ensure any air vents and drains are sealed.
- 5** Start the pressure pump.
- 6** As the fluid is pumped out of the 50/50 tank, make sure that the supply pump never sucks air.
- 7** Slowly add more fluid to the tank until all air has been expelled and the mixture starts coming out of the return hose in the 50/50 tank. (Keep the fluid level in the tank above the inlet of the suction hose.) This will flush the system of any debris and purge the lines of air.
- 8** Monitor the heating system during filling and purging to ensure:
  - all fittings remain secure
  - no leaks in any connections or hosing
  - good flow through the expansion tank
  - No pressure build up in excess of 7 PSI
- 9** If you discover any leaks, temporarily stop the filling procedure to repair the leak.
- 10** Continue running the pressure pump for about 10 minutes *after* it has purged all air from the system, and continue monitoring for leaks.
- 11** If you filled the system with straight water, drain it and refill it with a 50/50 mix of antifreeze and water.
- 12** Stop the pressure pump.
- 13** On the manifold, close valves 1 and 3 and open valve 2 to allow normal system operation.

## Section 8, Filling and Testing the Circulation System

- 14 Fill the overflow tank with fluid to the correct level.
- 15 Turn on the heater's circulating pump by putting the pump jumper.
- 16 Check that the circulating pump runs quietly and smoothly. If there is still bubbling or cavitation present, re-purge the system.
- 17 Verify the flow rate with an inline flow meter (see Figure 8-3 and Section 7-2).
- 18 Double check the entire plumbing system for leaks. Open and close any air vents to eliminate remaining air bubbles.
- 19 Recheck the fluid level and circulation in the expansion tank.
- 20 Remove the pump jumper on the control board. This returns the pump to normal operation.

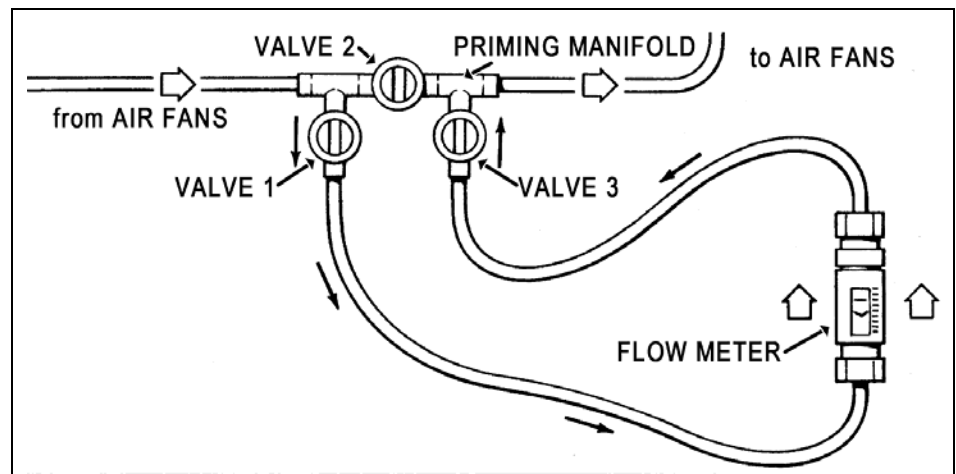

Figure 8-3: Flow Meter Inline with Circulation Loop

## 8.5 Verifying the Flow Rate

After filling, you must verify the flow rate using an inline flow meter. The purpose is to ensure the installation has been done correctly and the heater will operate effectively. If you do not have a flow meter, measure the temperature of the input and output hoses of the heater they should be under 20°F difference.

In a series-plumbed system, water flows through a single heating loop that consists of all the heater's elements—the pipe, fittings, burner, fans, etc. The entire system should have a flow of no less than 2 GPM. A flow slower than 2 GPM may be an indication of excessive resistance in the circulation system. Larger systems with more than five air fans should use a manifold to provide evenly distributed heat.

# Domestic Hot Water Heating



## 9.1 Before You Begin

The Hurricane® SCH25 Heater can provide domestic hot water. The domestic water heater, with an internal heat transfer coil, and using an adjustable aquastat (part # 1024), fastened to its storage tank, can be wired to the W1 and W2 terminals on the main control board to control the burner. We recommend a manual switch be wired in series with the aquastat.

During the summer months, when you need hot domestic water but don't need space heating, simply install a three way valve or electric solenoid to short loop the water through the heat exchanger only and not through the heating system. See Fig. 9-1. The selector valve should be mounted so it is easy to reach. See Figure 6-4 for details of the hookup of the electric solenoid.

Also, waste heat is transferred from the engine to the yacht for supplemental heat via a second heat exchanger. With the addition of an optional secondary water pump, this heat exchanger can also be used to pre-heat the yacht engine.

For help with wiring up the electrical components of the heat exchangers, see the Figure 6-4 wiring schematic in Section 6, *Wiring the Electrical System*.

## 9.2 Domestic Hot Water System

The components needed for installation and operation of the domestic hot water system include:

A heat exchanger can be added to provide continuous hot water after the stored hot water in the water tank has been depleted. The burner must be operating in order to supply continuous hot water.

**Heat exchanger** — The stainless steel flat plate heat exchanger is UL and CSA approved for domestic water heating. It can be installed for quick recovery and continuous hot water output after the hot water storage has been depleted.

**Aquastat** — An adjustable aquastat (part #1024) should be installed. This signals the burner to supply hot water.

**Mixing valve** — For temperature control and to prevent scalding since the domestic water could reach 170°F (77°C), a three-way adjustable valve (part#22014) should be installed. The valve is pre-set at 120°F (49°C) for the domestic hot water temperature, but it can be reset from 100° to 145°F (38° to 63°C). Once the temperature is set, the valve works automatically.

**Domestic water sensing switch** — If desired, you may install a manual switch to turn the domestic hot water sensing circuit on and off. This switch should be connected to the W1 and W2 terminals on the accessory terminal block.

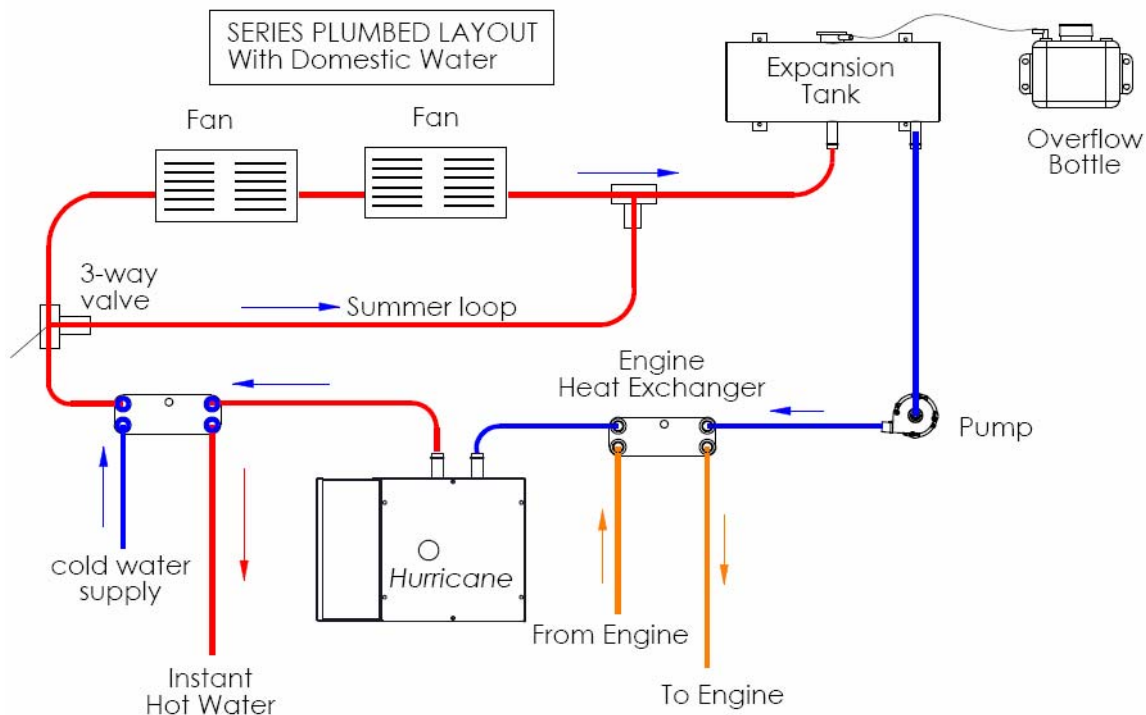

**Figure 9-1: Generic Series Plumbed Hurricane® SCH25 Hydronic System and Components**

Heat exchangers can be installed for engine waste heat, and preheat functions. You will need one heat exchanger per engine.

### 9.3 Engine Waste Heat Function

Besides space and domestic water heating, your HURRICANE® SCH25 heater can be used to both preheat your engine and to recycle waste heat produced by the engine.

A fresh water cooled engine produces a large amount of waste heat while running. You can use this waste heat, to heat your boat by adding an inline heat exchanger(s) to your heating system as shown in Fig. 9-1. A manual switch, and/or an aquastat attached to the water outlet of the engine, wired to A1 terminal, on the main board (see Figure 6-4) will start the circulating pump of your heating system (if any thermostat or domestic water aquastat is calling for heat), distributing waste engine heat to the entire boat. The heat exchanger will also preheat your engine by transferring heat to it, from the HURRICANE® SCH25 heater.



NOTE: The engine heat function can be used with the service switch ON or OFF.

#### NOTICE

**PRECAUTION:** Where there is a chance of contamination of your domestic water when using a heating system, use antifreeze specifically intended for hydronic heating systems. Inhibited propylene glycol is recommended. Do not use automotive, ethylene glycol, or any undiluted or petroleum based antifreeze as they can cause severe personal injury should antifreeze leak into your potable water supply. Double wall heat exchangers are available for potable water which will prevent contamination in the event of an internal leak.

It is not recommended to mix your engine cooling system with your heating system. Before connecting anything to your engine, consult your engine owner's manual for any restrictions or plumbing into the engine cooling system.



## Procedure

To set up the engine waste heat re-use function:

- 1 Install a switch, and/or an aquastat on the engine supply line to the heat exchanger, and wire to the A1 terminal on the main control board and battery (-) (see Figure 6-4).
- 2 Turn OFF, the ON/OFF control switch, located on the remote indicator panel. This will stop the burner from operating, but all other heater functions will operate normally. Start your engine.
- 3 When the engine aquastat heats up to its preset temperature, it will automatically switch on the circulating pump of the heating system (if any thermostats or domestic water aquastat are calling for heat). All other functions of the system will operate normally.
- 4 The circulating pump will continue to operate until the engine aquastat has cooled down or all thermostats or domestic water aquastat are satisfied. A manual switch can be wired in series with this aquastat to shut down the pump sooner if required.

## 9.4 Engine Pre-Heat Function

As an option, the heat exchanger can also be used to pre-heat an engine before starting it. Turn on the heater by a manual switch or timer wired to jumper the W-W terminal. If the heat exchanger is mounted upright, close to and near the bottom of the engine, it will transfer heat to the engine's cooling system through gravity circulation. A more positive solution is to install a pump on the engine side of the heat exchanger wired to an external power supply in series with a master switch.

Pre-heating the engine makes it easier to start and it can be put under load immediately.

If installed, the optional engine pre-heat function is enabled by flipping a manual switch mounted inside the living area (not supplied), while the engine is **off**. This turns on the secondary engine pre-heat pump.

The manual switch and engine water pump are wired to the yacht's electrical system through the heater control board.

### Procedure



To set up the engine pre-heat function:

- 1** Mount a manual switch in an appropriate place in the interior, usually near the dashboard.
- 2** Wire the manual switch to the engine water pump by connecting it to the main feed on the control board that connects to the yacht's power source (beside the battery connection, see Figure 6-4 in Section 6, *Wiring the Electrical System*). The switch circuit should include a 5 amp fuse on the power side.
- 3** Connect the ground-wire of the engine water pump to battery negative.
- 4** To test the engine pre-heat function, turn on the heater and allow it to come to temperature (about 10 minutes). Turn on the manual switch to start the engine pre-heat pump. Start the yacht engine, which should now be pre-heated to about 40°F (5°C) above ambient temperature.



# Operation



The initial start of your **HURRICANE® SCH25** heater must be done by an authorized service person. Be sure that all components have been properly installed according to the instructions laid out in this manual before the initial start.

## 10.1 Starting the Heater

The major steps in starting the heater are as follows:

1. Turn on the ON/Off control switch, located on the remote indicator panel.
2. Turn up the zone thermostat to a setting higher than room temperature.
3. Start the heater by switching the service switch to ON. This switch is located on the side of the electronic control box.

## 10.2 Signs of Normal Operation

When the heater is operating normally:



- The igniter will glow and the combustion air intake fan and the circulating pump begin to run. Whenever the pump is running, the green LED at the bottom of the LED display will be on.
- A few seconds later, the fuel pump starts delivering fuel to the regulator, the compressor turns ON, the fuel valve opens, and fuel is drawn to the air aspirating nozzle. The fuel is atomized and sprayed into the combustion chamber to start combustion.



After the ignition period (about 10 seconds), the igniter shuts OFF, and the burner continues to operate. The heater will operate until all the zone thermostats are satisfied, or until the heater reaches its normal water operating temperature of approximately 180°F. Once the normal operating temperature is reached, the burner itself will cycle off and the combustion fan will operate for an additional two minutes to purge the burner. If

a zone thermostat or domestic water heater aquastat is not satisfied, the circulating pump will continue to operate. If a thermostat cannot be satisfied by the residual heat in the system and the water temperature drops, the burner will restart and cycle until all thermostats are satisfied. Once all thermostats are satisfied, the heater will go through the two minute purge, and the circulating pump will cease. Alternatively, the circulating pump and cabin fans can be run using the A1 terminal on the control board (see Figure 6-3). A manual switch, and/or an aquastat attached to the water outlet of the engine, wired to the A1 terminal on the control board will control the engine heat function. The circulating pump will run once the engine heat is available (A1 connected to battery (-)) and any thermostat or domestic water aquastat is calling for heat. Note: The engine heat function can be used with the service switch ON or OFF. After the heater has been running for a little while, the water outlet of the heater case should become warm. If the water hose leaving the outlet of the heater does not warm up immediately after the pump comes on, water is not circulating properly and air may be in the system. Turn the heater OFF immediately and check water circulation.

### 10.3 Main Control Board Operation

Once the heater is operating normally, you must check the operating safety functions of the main board. To make sure the safety functions work properly, place your finger over the air filter inlet to the compressor, this will snuff out the flame. If you continue to block the air inlet, the heater will try to restart two more times and failing to do so will shut it down, stopping the compressor and fuel pump. This board will display a code 7. Reset the fault and the heater will continue with normal operation

### 10.4 Stopping the Heater (for Seasonal Purposes)

**NEVER shut off the power to the heater using the circuit breaker or a master switch, or disconnect the battery while the heater is running. Doing so will cause serious damage to the Heater, which will not be covered under warranty.**

To turn the Heater OFF, turn OFF, the ON/OFF control switch, located on the remote indicator panel, and turn OFF, the ON/OFF service switch on the main control board box. The room thermostat or the remote indicator panel ON/OFF switch can be turned ON or OFF at any time, without harming the heater. The

heater will automatically run through the purge cycle, which takes about two minutes.

## 10.5 Stopping the Heater (for Maintenance)

To shut down the heater totally, for maintenance purposes:

1. Turn OFF, the service switch on the electronic control box.
2. Wait until the heater has completed the purge cycle and turned itself OFF.
3. Disconnect the power supply.

## 10.6 Resetting a Fault

When a fault occurs and has been corrected, you can reset the fault by switching the service switch on the side of the main control box or the remote control switch OFF, then ON again. This will reset the fault and the diagnostic code. Note: component faults can only be reset using the service switch.

## 10.7 Electrical Noise

Noise is unwanted electrical signals, which produce undesirable effects in the electronic circuits of the control system and we must be aware of techniques to minimize the electrical noise on these controllers.

The majority of problems stem from crude wiring practices and techniques, which allow "coupling" or the transfer of electrical noise into the control circuit from the noise source. One common symptom is that the system is erratic, that is, evidence of a problem does not appear consistently. Even worse, it may give several different indications of a problem.

Low power level controllers that use electronic logic, especially those using integrated circuits, are more sensitive to noise. A typical noise source is any piece of equipment that can cause or produce very rapid or large amplitude changes in voltage or current when turned ON and OFF. A single side band transmitter is an example of this type of equipment.

Noise sources:

- Loose connections
- Switches and relay contacts operating inductive loads such as motors, coils, solenoids, and relays etc.
- All welding machinery
- Heavy current carrying conductors

- Fluorescent and neon lights

The sensor input and power output lines, as well as the power source line, all have the potential to couple or link the control circuit to a noise source.

Common Impedance Coupling occurs when two circuits share a common conductor. An example would be operating multiple, separate loads and the return lines from all are connected together and run back to the power source with one conductor. The best way to prevent this is to use independent leads for each return circuit and terminate them all at the same physical point.

Magnetic (Inductive) Coupling generally appears where there are wires running parallel or in close vicinity to each other. This is especially true when the wires from several different circuits are bundled together in order to make the system wiring appear neat. Electrostatic (Capacitive) Coupling is a function of the distance the wires run parallel with each other, the distance between the wires and the diameter of the wire. The best way to eliminate these is to run separate leads from separate circuits in separate bundles, taking special care to keep AC\* (high power lead) wires separated from DC (low power level) wires. If it is at all possible, twisted lead pairs and shielded cables should be used.

Electromagnetic (Radiation) Coupling occurs when the control circuit is very close to a high-energy source that is capable of magnetic or electrostatic induction of a voltage. A common source of such radiation is an inverter, alternator, generator, motor transformers, fluorescent lights, radio, TV, and navigation equipment.

\*Note that special attention should be given to the AC power line because it is a source of unusual types of noise-related problems in control circuits.

# Troubleshooting

## 11.1 Overview

The electronic board consists of a flash micro controller programmed to monitor the timing and safety function of the heater. Each time the board is energized by a call for heat, it will check its own circuits for any problems. Should a problem exist, the board will shut down.



You can easily monitor your HURRICANE® SCH25 heater's operation by checking the electronic control box. Any fault or problem will be immediately picked up by the control board and an LED diagnostic code indicator will light up to pinpoint the fault. Once the fault has been corrected, it can be reset by switching the service or remote switch OFF, then ON again. The diagnostic codes are described below.

## 11.2 Power On (Green)

The POWER ON indicator is lit whenever the service switch on the control box is ON and if the remote panel is switched ON, a small red LED near the lower right hand side of the digit on the remote panel will also glow. If this light does not come on, check to see if the service switch is ON.

If the power on light does NOT come on:

- Check for a blown fuse.

## 11.3 Burner On

No diagnostic code will be displayed on the main board or the remote panel when the burner is ON and operating normally. A

small red LED will glow near the lower right hand side of the digital on the remote panel indicating it is ON.

## 11.4 U – Service Switch Off

The service switch is switched OFF.

- The burner will shut down if it has been running.
- The diagnostic code, U will be displayed.
- The control board will purge the system with the combustion fan and circulating pump for two minutes. At the end of the purge period, the system will power down and will go into a low power consumption mode (10mA max.). There will not be any display or led's lit.

## 11.5 E Remote Switch Off

The remote panel is switched OFF.

- The burner will shut down.
- The diagnostic E code will be displayed.
- The control board will purge the system with the combustion fan and circulating pump for two minutes.

If the remote switch is put in the ON position, the control board will resume operation and a small red LED will glow near the lower right hand corner of the digit. If there is no diagnostic code displayed or small LED glowing:

- Make sure the service switch is ON.
- Make sure the remote switch cable is plugged into the control box and remote switch.

- Make sure the remote rocker switch is working.
- Check the cable continuity.

## 11.6 **C** Heater Cycling (Normal Operation)

The operating aquastat installed on the water jacket has been satisfied.

- The burner will shut down.
- The diagnostic code, **C** will be displayed.
- The control board will purge the burner with the combustion fan for two minutes and then stop. The circulating pump will run until the last thermostat is satisfied, then purge for two minutes and stop.
- To maintain the system temperature the operating aquastat will cycle the burner off at 170° F (77°C) and on again at 140°F (60°C).
- If the heater cools and fails to resume operations and the diagnostic code **C** continues to be displayed, the aquastat is faulty or has an open connection.

## 11.7 **E** - Thermostats Off (Normal Operation)

All thermostats and aquastats are satisfied.

- The burner will shut down.
- The diagnostic code, **E** will be displayed.

- The control board will purge the system with the combustion fan and circulating pump for two minutes. When any thermostat or aquastat calls for heat, the heater will resume normal operation.
- If the heater fails to resume operations, check the thermostat and their connections.

## 11.8 0 - Voltage Low or High

The battery or power supply voltage is below 11Vdc or above 15Vdc

- The burner will shut down.
- The diagnostic code, 0 will be displayed.
- The buzzer will sound for 10 seconds.
- The control board will purge the system with the combustion fan and circulating pump for two minutes while it is checking if the voltage fault is still present.

If the voltage fault has cleared, the control board will reset the alarm and restart the burner. If the condition has not cleared by the end of the purge period, the diagnostic code 0 will remain displayed. The control board will continue to check the voltage every half hour until the voltage fault has cleared and then restart the burner. To manually reset the fault, switch the service switch or the remote panel switch OFF then ON again.

## 11.9 I - Overheat

The high temperature limit has been reached.

- The burner will shut down.

- The diagnostic code, 1 will be displayed.
- The buzzer will sound for 10 seconds.
- The control board will purge the system with the combustion fan and circulating pump for two minutes while it is checking if the overheat condition exists. If the condition exists, the diagnostic code 1 will continue to be displayed.
- In order to restart the burner, first check the circulating pump, the level of the coolant, and the movement of the coolant while the circulating pump is running. Reset the high limit aquastat (inside heater) and the fault (switch service or remote switch OFF then ON again). If the fault does not reset, check for a faulty aquastat and proper ground. If equipped with AC elements, reset the AC hi-limit aquastat also.

If a number 1 diagnostic code lights up and the heater is not in an overheat condition, check the ground from the heater ground wire to the battery. The ground wire should be a minimum 10 gauge and connected directly to the battery.

### 11.10 2 - Fuse Blown

One of the fuses on the control board has blown.

- The burner will shut down.
- The diagnostic code, 2 will be displayed.
- The buzzer will sound for 10 seconds.
- The control board will purge the system with the combustion fan and circulating pump for two minutes while it is checking for a blown fuse.
- If a blown fuse exists, the diagnostic code 2 will continue to be displayed.
- In order to restart the burner, replace any blown fuses with one of the proper size. Then reset the fault by switching the service switch or the remote panel switch OFF then ON again.

## 11.11 3 - Fuel Pump/Solenoid

The fuel pump or fuel solenoid has shorted.

- The burner will shut down.
- The diagnostic code, 3 will be displayed.
- The buzzer will sound for 10 seconds.
- The control board will purge the system with the combustion fan and circulating pump for two minutes.
- In order to restart the burner, check the fuel pump and solenoid for a short circuit. Then reset the fault by switching the service switch OFF then ON again.

The remote panel switch does not reset short circuit faults.

## 11.12 4 - Ignitor

The ignitor is open or shorted

- The burner will shut down.
- The diagnostic code, 4 will be displayed.
- The buzzer will sound for 10 seconds.
- The control board will purge the system with the combustion fan and circulating pump for two minutes.
- In order to restart the burner, check the ignitor and connections. Then reset the fault by switching the service switch or the remote panel switch OFF then ON again if the ignitor is open or by the service switch only if the ignitor is shorted.
- The remote panel switch does not reset a short circuit fault.

### 11.13 5 - Combustion Fan

- The combustion fan or shorted.
- The burner will shut down.
- The diagnostic code, 5 will be displayed.
- The buzzer will sound for 10 seconds.
- The control board will purge with the circulating pump for two minutes.
- In order to restart the burner, check the combustion fan. Then reset the fault by switching the service switch or the remote panel switch OFF then ON again if the combustion fan is open or by the service switch only if the combustion fan has shorted.
- The remote panel switch does not reset a short circuit fault.

### 11.14 6 - Water Pump

The water pump is shorted.

- The burner will shut down.
- The diagnostic code, 6 will be displayed.
- The buzzer will sound for 10 seconds.
- The control board will purge with the combustion fan for two minutes.
- In order to restart the burner, check the water pump. Then reset the fault by switching the service switch OFF then ON again.
- The remote panel switch does not reset a short circuit fault.

## 11.15 7 - Flame Out

The flame went out or did not ignite.

- The burner will shut down.
- The diagnostic code, 7 will be displayed.
- The control board will try to restart the burner two more times. After two unsuccessful restart attempts, the buzzer will sound for 10 seconds.
- The control board will purge with the combustion fan and circulating pump for two minutes. The diagnostic code 7 will continue to be displayed.

The single most common reason for flame out faults is when air gets into the fuel system. This is normally caused by loose fittings or when your fuel supply is teed off a fuel line used by your engine or generator. As air accumulates and passes through the nozzle, it interrupts the fuel and shuts down the burner. When this happens, it may be necessary to reset the fault a few times to ensure all air has passed through the system. If the burner resumes normal operation, you must find the source of the air leak, otherwise, this fault will continue to occur. An Air Accumulator has been installed to collect the air before it reaches the nozzle. Check regularly and bleed if necessary. Air which is collected is an indication of a leak somewhere in the fuel system.

- Check the connections on the fuel tank, fuel pump, the regulator, and at the nozzle for air leaks. Find source of air entry and repair. Make sure the nozzle or fuel filter is not clogged.
- Check the airline hoses for any restriction of airflow through the compressor. Restrictions may be caused by a crimped hose, clogged air filter, or a loose or leaking air hose from the compressor outlet to the nozzle. Check the air filter inlet for any obstructions.
- Check for negative pressure in the area around the heater. When the engine is running, it can draw air back through the

heater's exhaust pipe. All intake air and exhaust connections must be tight.

- Check for restrictions or leaks in the combustion air intake hose or exhaust pipe.
- Check for open circuit on fuel pump/solenoid and compressor.

To restart the burner, check the fuel supply and clean the nozzle. Then reset the fault by switching the service switch or the remote switch OFF then ON again.

- If when reset, the board shuts down without trying to restart the burner, the board or flame sensor is defective.
- If the conditions that caused the flame fault have been addressed and the heater continues to not ignite, the thermal cutoff may have been activated by an overheat condition within the burner box. Using a multimeter, check for continuity across the leads of the thermal cutoff. The thermal cutoff is located inside the burner box, and is mounted at the top middle of the box. If there is no continuity, the heater **MUST** be inspected and the reason for the overheat condition determined and corrected before further use. A replacement thermal cutoff must be obtained from your dealer.

### 11.16 8 - Compressor

The air compressor has shorted.

- The burner will shut down.
- The diagnostic code, 8 will be displayed.
- The buzzer will sound for 10 seconds.
- The control board will purge the system with the combustion fan and circulating pump for two minutes.
- In order to restart the burner, check the air compressor. Then reset the fault by switching the service switch OFF then ON again.
- The remote panel switch does not reset a short circuit fault.

## 11.17 **⤴** - Bypass Mode

The bypass mode is a service feature to be used by authorized service personnel only. The bypass mode overrides the remote switch, voltage fault, fuse blown fault, flame out fault, open ignitor fault, open fan fault, and thermostats. All these safety devices will be bypassed for five minutes.

- While in the bypass mode, the diagnostic code, **⤴** will be displayed and the Power ON LED will flash rapidly.
- If the heater cycling aquastat is satisfied or the overheat limit is reached, the burner will stop and purge for two minutes while displaying the diagnostic codes, heater cycling, **C** or **I**, for overheat, and the Power ON LED will flash slowly. You will have to wait for the heater to cool before continuing in the bypass mode. The bypass mode will timeout in five minutes. After the first three minutes running, it will automatically purge for the last two minutes.

## 11.18 Water Pump On (Green)

The green light located directly under the LED digit on the main board will come on whenever the circulating water pump is energized.

## 11.19 Test Points

The test points on the electrical control board allow for testing and troubleshooting of the ITR heater's electrical system. You will need a voltage meter to plug into the test points.

## Section 11. Troubleshooting

Test Point	Component	Results / Optimal Condition
TP1	Flame Sensor	A voltage meter should show a voltage of 0 to 4 volts if the flame sensor detects a flame. If not, the voltage will be 0 volts.  An oscilloscope will show a 0 to 5 volt square wave with a frequency of 20 Hz to 2000 Hz, if the flame sensor is detecting a flame.
TP2	Combustion Fan	The voltage will be between 4 and 5 volts if the combustion fan is operating correctly; 1 volt if the combustion fan is not drawing any current (open).
TP3	Combustion Fan Current	The voltage will be between 1 and 5 volts if the combustion fan is drawing normal current, and 0 volts if the combustion fan is not drawing current.
TP4	5v Power Supply	The voltage should be between 4.8 and 5 volts. A lower voltage indicates a problem with the voltage supply to the logic of the control board.
TP5	8v Power Supply	The voltage should be between 7.9 and 8 volts. A lower voltage indicates a problem with the voltage supply to the logic of the control board.
TP6	Power To Control Board	This is the battery voltage supplied to the control board; it should be between 11 and 15 volts.
TP7	Power To Flame Sensor	The power to the flame sensor should read between 11 and 15 volts (same as battery voltage).
TP8	Cycling Aquastat	The voltage will be between 4.8 and 5 volts if the heater is cycling (cycling aquastat is open), and 0 if the cycling aquastat is closed.
TP9	Overheat Aquastat	The voltage will be 0 volts if an overheat condition is occurring or has occurred in the past two minutes (overheat aquastat is open). The voltage will be between 4.8 and 5 volts if the overheat aquastat is closed.
TP10	Voltage Fault	The voltage will be 0 volts if there is no voltage fault, and between 4.8 and 5 volts when there is a voltage fault.
TP11	Remote Switch	The voltage will be 0 volts when the remote switch is off, and between 4.8 and 5 volts when the switch is on.
TP12	Reset	The voltage will be 0 volts when the reset button is pressed, and between 4.8 and 5 volts when the reset button is not engaged.
TP13	Thermostats Or Domestic Water	The voltage will be 0 volts when the thermostat or domestic water system calls for heat and between 4.8 and 5 volts when heat is not called for.
TP14	Blown Fuse	Blown fuses for the burner, pump, or cabin fans will show a voltage of between 4.8 and 5 volts. Good fuses will show 0 volts.



## 11.20 LCD Readout Remote Panel (optional)

This panel will display the diagnostic explanation, which will match up to the diagnostic code on the main board. A small buzzer will sound for 10 seconds to alert you of a fault.



## 11.21 Flame Sensor Module

The Flame Sensor consists of a sealed module with a photodiode aimed at the flame, a red LED indicator light and 3 wires, red (+), black (-), and yellow (signal) connected to the main board. Under normal operating conditions whenever the burner ignition begins, the red LED will flash once indicating the red and black wires are connected and the module is receiving power and working properly. Once the burner is ignited, the LED will begin to flicker like the flame. If for any reason the flame is extinguished, the flickering will stop and the board will shut down the heater. If the yellow (signal) wire is disconnected, the board will shut down. If all the wires are properly connected with module flashing and the board still shuts down, diagnostic code 7 Flame Out, the board may be defective.

## 11.22 Reduced Output

The heater may run without faulting, but at a reduced output. If this is noticed, it could be caused by the following:

High altitude

Dirty nozzle

Defective regulator

Too small a nozzle

Poor water circulation

Ash deposit in combustion chamber

## 11.23 Smokey, Smelly Exhaust

The heater may run without faulting, but you may experience signs of soot, exhaust smoke and/or a pungent smell. This is usually caused by the wrong fuel to air mixture. This can be affected by the following:

Low voltage

High altitude

Dirty compressor air filter

Low compressor air output

Restricted combustion air flow (intake hose / exhaust hose / combustion chamber)

Low combustion fan output (defective motor / wrong rotation / dirty fan blade)

Partially clogged grooves in nozzle distributor

## 11.24 A Silent Killer

The American Boat and Yacht Council Inc. (ABYC) states:

Section 5.111: "Where heater is installed in an engine or bilge space, 100% fresh air shall be supplied for combustion.

Section 6.1: "Burners shall be of the mechanical draft type which employs a power driven fan, blower or other mechanism supplying air for combustion."

This means 100% fresh combustion air must be mechanically delivered through a sealed duct directly to the heater from outdoors. This is the recommended procedure no matter where the heater is installed. When combustion air is drawn from an unventilated heated space, the heater flame will become increasingly yellow as the oxygen in that space is consumed. An oxygen-starved flame produces excessive carbon monoxide (CO), some of which can easily escape the exhaust. Even with one porthole barely open, air doesn't circulate enough.

Carbon monoxide is a colorless, odorless, tasteless gas produced any time you burn a carbon-based fuel such as gasoline, wood, charcoal, kerosene, propane, or diesel. It disperses freely in the air and can accumulate in enclosed spaces or air pockets. Boaters are especially vulnerable to the dangers of CO because boats typically have gas or diesel engines, as well as fuel-burning appliances, and their enclosed spaces tend to accumulate CO. Because CO is a cumulative poison, it can have fatal effects even at low concentrations. It is absorbed by your lungs like oxygen, and attaches to your red blood cells. When your blood can no longer transport sufficient oxygen to the brain and other tissues, you essentially asphyxiate. Any device that burns fuel creates CO, so your cooking stove and heater are both potential sources, especially if poorly ventilated.

The exhaust systems are under constant attack from salt water, gases, vibration, and normal wear. Inspect every exhaust system aboard your boat on a routine basis. Start with a visual inspection. Check each joint for discoloration, carbon buildup, stains, water leaks, or other signs of damage. Inspect all metal parts for corrosion. Check that clamps are in good condition and secure. Ensure that all ventilation systems are in good working order and not blocked. An untuned, poorly running engine or heating appliance produces excessive CO. Make sure it is tuned up, maintained, and runs smoothly. It should never produce black smoke.

Section 2.1: "All components including frames, fuel filters, solenoid valves, fuel pumps, blowers, shall be of a type suitable for the application., i.e., resistant to corrosion in salt atmosphere, capable of proper operation under conditions of vibration, shock, and the pitch and rolling action of the boat. Refer to applicable ABYC standards. Gravity hot water, gravity hot air and high pressure steam systems are not recommended for boat use."

Make sure the heater you intend to buy is constructed of corrosion resistant material including the internal parts like the burner, combustion chamber, and water jacket. Parts made of steel or even painted steel will corrode and are very expensive to replace besides being dangerous to your health. All the major parts of the Hurricane® SCH25 Heater are constructed of corrosion resistant materials.

# Maintenance



## 12.1 The First Few Weeks

Once your HURRICANE® SCH25 heater has been installed to approved standards and workmanship, and you have test operated it a few times, your HURRICANE® SCH25 heater requires little maintenance.

About two weeks after your HURRICANE® SCH25 heater has been running, you should conduct a general inspection of the entire system.

Check for any leaks in the exhaust, fuel, or water systems. Tighten all clamps.

**It is strongly recommended that the HURRICANE® SCH25 heater be started and allowed to run through one complete heating cycle at least every 30 to 45 days to ensure its proper function and to verify the proper operation of all components.**

## 12.2 Adding Antifreeze

Once the system has been filled with water and purged of all air during the installation procedure, you need to operate the heater at normal temperatures and then check for water leaks. If you do not find any, add antifreeze to lubricate the pump and prevent the water system from corroding or freezing in cold weather. See Chapter 3, "Water filling procedures", page 3-11.

PRECAUTION: Where there is a chance of contamination of your domestic water when using a heating system, use antifreeze specifically intended for hydronic heating systems. Inhibited propylene glycol is recommended. Do not use automotive, ethylene glycol, or any undiluted or petroleum based antifreeze as they can cause severe personal injury.



IT IS VERY IMPORTANT THAT YOU NEVER USE WATER ONLY AS A COOLANT.

We recommend that you add a mixture of 50% water and 50% antifreeze. NEVER use more than a 50/50 mixture, since the added viscosity of the antifreeze solution will cause circulation problems. Your antifreeze/water mixture should be changed every three years. Antifreeze does wear out and can become very acidic.

A coolant conditioner can be added to the water system, to keep the coolant alkaline and not acidic, see page 3-14. These inhibitors also prevent the coolant from forming calcium scales. Conditioners are available from diesel engine manufacturers to maintain water stability and prolong heater life. If a conditioner is not installed in your system, check the pH level yearly. The components inside the heater should not normally require maintenance, except for periodic checks for obvious problems, such as leaks or overheating.

## 12.3 Marine Exhaust System

Always be careful that nothing combustible is placed adjacent to the exhaust pipes.



While the exhaust system is made of a high quality stainless steel material, it is still affected by the marine environment. Check the general condition of the pipes every so often for possible leaks and corrosion. You should service as required and replace corroded pipes immediately. On rough seas, there is a danger of water entering the exhaust outlet. Ask your dealer about a thru-hull plug that can be inserted into the exhaust outlet when the boat is moving through rough water. Obviously, the heater cannot be operated when the exhaust system is plugged.

## 12.4 Nozzle

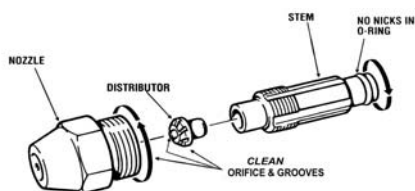

Nozzle problems such as clogging will result in a poor flame, small and blue. Carefully disassemble. Hold nozzle vertically and turn stem counter clockwise. Clean distributor orifice and air slots of any debris using solvent and high pressure air. Check O-rings for nicks and replace if in doubt. A leaking O-ring will allow air into the fuel causing popping of the flame.

## 12.5 Fuel Lines and Filter

You should check your filter every season to determine if it needs replacement. The frequency depends largely on the quality of fuel you've been using.

## 12.6 Combustion Chamber



The quality of the fuel varies and some ash is left in the chamber after combustion. The burner and combustion tube must be removed and the combustion chamber vacuumed clean every 1000 hours. If this is neglected, the exhaust will be restricted and will cause the combustion chamber to burn out. The exhaust pipe should be checked and also be vacuumed, if required.

## 12.7 Checking Hoses and Tubes

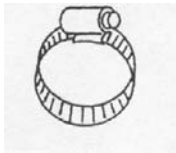

Every so often, check all water hoses and tubes for leaks or weak points. Tighten all clamps and replace any sections of worn hose immediately.

## 12.8 Electrical System

The electronic control panel should not normally require servicing, except for the following:

Make sure that all your connections are secure.

Periodically, do a voltage test to ensure that you are getting 12 volts from the battery.

Check for corrosion of wires.

## 12.9 Recommended Spare Parts

Like any piece of machinery, your HURICANE heater will need servicing from time to time. A suggested maintenance schedule, page 12-4, lists suggested maintenance items and intervals. The following is a list of parts recommended to have on hand.

- Fuel filter cartridge
- Air filter
- Fuel nozzle for your model
- Fuel nozzle "O" ring
- Flame Sensor

Over a period of time, operational parts of the heater will wear out and need replacing:

- Air compressor
- Fuel Pump
- Water Pump or pump brushes
- Fan Motor
- Ignitor
- Aquastats

<b><u>MAINTENANCE ITEM</u></b>	<b><u>MAINTENANCE FREQUENCY</u></b>	<b><u>SERVICE REQUIRED</u></b>
FUEL/WATER HOSES	SEASONALLY	INSPECT FOR LEAKS AND WEAK POINTS
HOSE CLAMPS	SEASONALLY	INSPECT FOR CORROSION TIGHTEN IF LOOSE
COMBUSTION CHAMBER AND EXHAUST	1000 HOURS	VACUUM CLEAN
FUEL FILTER	SEASONALLY	INSPECT FOR CLEANING OR REPLACEMENT
NOZZLES DISTRIBUTOR ORIFICE, AIR SLOTS & O-RINGS	SEASONALLY OR 2000 HOURS	CLEANING AND INSPECTION FOR WEAR AND DAMAGE
EXHAUST SYSTEM	SEASONALLY	INSPECT FOR LEAKS AND CORROSION
COOLANT MIXTURE	36 MONTHS 12 MONTHS	REPLACE Ph LEVEL FOR ACIDITY
ELECTRONIC CONTROL PANEL	SEASONALLY	VOLTAGE TEST / INSPECT FOR CORRODED WIRES
AIR COMPRESSOR FUEL PUMP COMBUSTION FAN MOTOR	SEASONALLY	INSPECT FOR LEAKS, CORROSION & WEAR

**Figure 12-1 Maintenance Schedule**

## 12.10 Protecting Hydronic Heating Systems

The advantage of closed hydronic heating systems is that as long as there are no leaks, (i.e., no need for constant make-up water), the fill neutralizes (that is, it reaches equilibrium). The long term result is minimal scale build-up and insignificant corrosion since after operating for a period of time, most oxygen has been "starved" out of the boiler fill water. While boiler fill water treatments have their place, leak prevention is the single most important preventative maintenance item.

Regular maintenance and prompt repair of leaks, combined with a one time application of appropriate inhibitors, can help you enjoy problem-free heating. Since it is difficult to guarantee that a hydronic heating system will never leak, corrosion inhibitors and scale inhibitors added to "fresh" boiler fill water can act as low cost "insurance" for hydronic systems.

### Causes of Scale

Tap water is the most typical source selected for boiler fill water. Water contains dissolved solids such as magnesium and calcium which when heated becomes much less soluble and forms scale. Scale comes out of solution in the largest amounts where the temperature is highest in the system (i.e., the boiler heat exchanger). As the scale builds up, noise and cold spots develop since scales plug up water channels and acts as an insulator that impedes proper heater transfer.

### Acidity and Corrosion

Corrosion is the result of metal oxidizing (that is, metals reacting with oxygen-rich boiler fill water). The acidity of any liquid (including water) is a good indicator of how much corrosion will actually take place. As a rule of thumb, boiler fill water should have a pH greater than 7 and less than 10.5. The key to preventing corrosion is to make sure that the heating system is free of leaks and there is no need to replace it with fresh, oxygen rich boiler fill water. Corrosion inside a hydronic heating system stops quite quickly as the fill water stabilizes and becomes oxygen-starved. The pH should be measured at least annually.

Since most hydronic heating systems are comprised of different metals (e.g., iron, copper, etc.), and since boiler fill water is an electrolyte (that is, it will conduct electrical current), electro-

chemical reactions ("galvanic" reactions) can take place. As the fill water stabilizes, however, it becomes a very weak electrolyte, so galvanic corrosion rarely becomes a problem - as long as the system remains leak-free.

### **Preventative Treatments**

Corrosion and scale inhibitors are relatively inexpensive. Ideally, they should be applied, once only, at the time of a new installation or whenever a system has been completely drained. Boiler water treatment specialists almost unanimously agree that the prevention of leaks and the elimination of the need for frequent boiler water make-up are top priorities for hydronic systems.

# Warranty And Service

## 13.1 Warranty

**Warranty cards must be filled in completely, signed by the Owner and Dealer and returned to ITR within 30 days of the date of the original installation.**

ITR warrants the **HURRICANE®II/IIL/COMBI, SCH25, Water Heater by ITR, (referred to as “heater(s)”) and all accessories or other supplied components with the original purchase to be free of defects in materials and workmanship under design usage and service conditions for two (2) years from the heater serial number label manufacturing date. Warranty replacement parts are covered for the remainder of the heater’s warranty.**

**This warranty does not apply to damage or failure of the heater, or the vessel or vehicle into which it was installed, due to improper installation, assembly, maintenance, or abuse, accident, or the use of parts not supplied by ITR.**

## 13.2 Installations

The purchaser and installer are advised that specific rules and regulations may be in effect with respect to the installation of the “heater”. It is the installer’s responsibility to review and comply with all such rules and regulations.

Non-standard installations, that is, those requiring a departure from published installation instructions, should not be undertaken without first having consulted and obtained the written approval of ITR. Coverage for warrantable parts will, at the discretion of ITR, be made to the claimant in the form of repair, replacement, or credit.

**“Heaters” installed using non standard, industry accepted procedures and without ITR’s or an authorized Dealer’s approval will be limited to a 90 day warranty measured from the heater serial number label manufacturing date.**



### 13.3 Limited Warranty

**The following warranties are in lieu of all other warranties and conditions. ITR makes no other warranties, representations, or conditions, express or implied, and there are expressly excluded all implied or statutory warranties or conditions of merchantability of fitness for a particular purpose and those arising by statute or otherwise in law of from a course of dealing or usage of trade.**

**The stated express warranties are in lieu of all liabilities or obligations for damages arising out of or in connection with the delivery, use, performance, or licensing of the product or in connection with any services performed. In no event whatsoever, shall ITR be liable for indirect, consequential, exemplary, incidental, special or similar damages including but not limited to lost profits, lost business revenue, failure to realize expected savings, other commercial or economic loss of any kind or any claim against ITR by any other party arising out of or in connection with the sale, delivery, use, performance, or repair or in connection with any services performed, even if ITR has been advised of the possibility of such damages, whether based upon warranty, contract, or negligence. ITR's maximum liability shall not in any case exceed the contract price for the products claimed to be defective. ITR warrants its products; ITR authorized dealers/service centers and installers provide warranty for installation. Any warrantable service and or labour is the responsibility of ITR and should be performed by an authorized dealer unless other arrangements are authorized.**

**No one is authorized to increase, alter, or enlarge ITR's responsibilities or obligations under these warranties. Warranties are void if the original serial number has been removed or altered, or cannot be readily determined.**

## 13.4 Owner's Responsibilities

**Before the expiration of the warranty, the Owner must give notice to a registered ITR Dealer of failures, if any, considered to be warrantable and deliver the defective "heater" to such dealer.** The Owner is responsible for all repairs made to the engine, equipment, vessel, or vehicle in which the "heater" is installed, other than the "heater". The Owner is responsible for lodging, meals, and other incidental costs incurred by the Owner as a result of a warrantable failure. The Owner is responsible for "down time" expenses, and all business costs and losses resulting from a warrantable failure.

**ITR IS NOT RESPONSIBLE FOR INCIDENTAL OR CONSEQUENTIAL DAMAGES.**

## 13.5 Not Covered Under Warranty

This warranty will not apply to:

- Normal usage, wear, and tear on parts, including but not limited to, fuel filter, air filter, nozzle, fuses, igniter, and carbon brushes.
- Parts or products which malfunction due to improper installation, including but not limited to malfunctions causing inadequacies in; air, fuel or coolant flow, voltage due to wiring, shock or vibration.
- Any progressive damage to the engine, vessel, or vehicle arising out of failure of the "heater".
- "Heaters" which have been modified or use of non-standard parts not approved by ITR.
- "Heaters" that have been abused, damaged, vandalized, or received improper maintenance.
- **Removal and re-installation expenses of the "heater" unless specific written permission has been obtained from ITR.**
- Travel time and expenses incurred by an ITR dealer or other personnel to perform warranty related work on the "heater"

- Diagnosis or repairs when caused by problems not directly related to the “heater” or due to empty fuel tanks or poor fuel quality, fuel additives, acidic water, electrolysis, incorrect vessel bonding leading to abnormal corrosion.
- Running the system dry or without appropriate preservatives (antifreeze), causing damage to the heat exchanger, pump seals, etc.
- Exposing the heater to an environment detrimental to its effective operation (such as excessively wet, dirty, or hot areas).
- Other products which ITR does not manufacture.
- Any products or parts which have been used in a manner contrary to ITR’s printed instructions.

**PLEASE FOLLOW THE RECOMMENDATIONS INCLUDED IN THIS MANUAL.**

## 13.6 Customer Service Calls

Normal service calls are at the owner’s expense.

**CHECK THE TROUBLESHOOTING CHAPTER OF THIS MANUAL TO SEE IF YOUR PROBLEM IS ADDRESSED.**

When calling with a service problem, please have the following information at hand:

- The model number and serial number of your heater and main electronic control board.
- If your heater is already installed, ensure you are familiar with the design and installation setup.
- Have ready a detailed description of the problem and keep the manual handy to refer to.

## 13.7 Returns

**To obtain warranty service, the owner must:**

- Provide a full description of the problem to your dealer and ITR. ITR will determine if the problem is covered under the ITR warranty.

- If ITR determines that the problem is covered under warranty, they will provide you with a Repair or Return Goods Authorization (RGA) number for any warranty return, repair or service.. ITR will refuse any return package without a proper RGA number.
- If ITR determines that “heater” repairs will be covered under warranty under in-field conditions, ITR will authorize the in-field warranty service personnel as to specific conditions and limits for parts and labor used in the repair. Any other incurred costs will not be covered under the warranty.
- When shipping your product, pack securely to prevent damage, indicate the RGA and serial number of the heater on the outside of the shipping container, and ship prepaid and insured to ITR.
- In the shipping container, provide written details of the problems, RGA number, manufacturing date as indicated by the serial number label, serial number, proof of purchase, and a return address.

**After repair or replacement** of products under warranty, ITR will return the product to the customer via standard (non expedited) delivery. Factory repairs or replacement will be done as quickly as possible, with an estimated five working day turn around.

## 13.8 Telephone Service



There is no charge for help or service information given over the telephone or by fax. Any recommendation or advice from ITR or any of its employees, or Dealers, is given only in good faith as an accommodation to the customer. Such information should not be relied upon by the customer without an independent verification of its applicability to the customer’s particular situation. For customer service or other information:

**Call the Dealer from whom you bought the heater, or call ITR**

**IN CANADA:**

**2431 Simpson Road,**

**Richmond, BC Canada V6X 2R2**

**Tel: 1-800-755-1272 or 604-278-1272**

**Fax: 604-278-1274**

**Email: [info@itrheat.com](mailto:info@itrheat.com)**

**IN THE UNITED STATES:**

**11915 NE 56<sup>th</sup> Circle Suite B**

**Vancouver, WA USA 98682**

**Tel: 1-800-993-4402 or 360-993-4877**

**Fax: 360-993-1105**

**Website: <http://www.itrheat.com>**

PLEASE FILL OUT FOR YOUR OWN REFERENCE

## INTERNATIONAL THERMAL RESEARCH

CANADA 2431 Simpson Road,  
Richmond, B.C. Canada V6X 2R2  
Ph 604-278-1272 Fax 604-278-1274  
[www.itrheat.com](http://www.itrheat.com)

### WARRANTY REGISTRATION CARD

Limited Warranty see manual  
(Please print or type)

#### HEATER

Serial No. \_\_\_\_\_

→ SERIAL NUMBER **MUST** BE RECORDED FOR WARRANTY TO APPLY

Installed by:      Owner     Dealer

Date Installed: \_\_\_\_\_

Date Purchased. \_\_\_\_\_

#### TYPE OF INSTALLATION

Marine     RV     Truck     Other

#### OWNER

\_\_\_\_\_  
Name

\_\_\_\_\_  
Address

\_\_\_\_\_  
City

\_\_\_\_\_  
State / Province

\_\_\_\_\_  
Country

\_\_\_\_\_  
Zip / Postal code

\_\_\_\_\_  
Telephone

\_\_\_\_\_  
Signature

\_\_\_\_\_  
Date

#### AUTHORIZED DEALER NAME

**NOTE:** THIS WARRANTY CARD MUST BE FILLED IN COMPLETELY, SIGNED BY THE ORIGINAL OWNER AND THE DEALER AND RETURNED TO ITR WITHIN 30 DAYS OF THE DATE OF INSTALLATION.