

**THE**  
**WindowWasher**  
**BY ITR**  
**CONTINUOUS HOT WATER FOR WINDOW WASHING**

*from Calcutt Boats*

# Installation and Operating Manual

Diesel Fired Continuous Output  
Window Cleaning Water Heater

**CE**

**Copyright © January 2010**

**MANUFACTURED BY:**

**International Thermal Research  
2431 Simpson Road,  
Richmond, BC, Canada, V6X 2R2  
Tel: +1 604-278-1272  
Fax: +1 604-278-1274  
Email: [itr@shaw.ca](mailto:itr@shaw.ca)  
Website: [www.itrheat.com](http://www.itrheat.com)**

**SOLE EUROPEAN DISTRIBUTORS:**

**Calcutt Boats Ltd.  
Tomlow Road, Stockton,  
Southam, CV47 8HX, UK  
Tel: +44 1926 813757  
Fax: +44 1926 814091  
Email: [info@dieselheating.com](mailto:info@dieselheating.com)  
Website: [www.dieselheating.com](http://www.dieselheating.com)**

All rights reserved. No part of this manual may be reproduced or transmitted in any form by any means, electronic or mechanical, including photocopying and recording, information storage, retrieval, or transmission, without permission in writing from International Thermal Research and/or Calcutt Boats Ltd.

**Disclaimer:**

Due to our commitment for quality and ongoing product improvement, ITR & Calcutt Boats reserve the right to modify or change without notice, any materials, applications, equipment, accessories, and/or prices. All measurements and weights are approximate.

# Table of Contents

<b>Section 1, Overview</b> .....	<b>1</b>
1.1 Unpacking the WindowWasher .....	2
1.2 Protect Your Warranty .....	2
1.3 The WindowWasher™ by ITR Features .....	3
1.4 Critical Factors .....	4
1.5 Equipment, Tools and Skills.....	4
1.6 Testing and Inspection .....	5
<b>Section 2, Mounting the WindowWasher</b> .....	<b>7</b>
2.1 Before You Begin .....	7
2.2 Your Mounting Location .....	8
2.3 Procedure .....	9
<b>Section 3, Installing the Exhaust System</b> .....	<b>11</b>
3.1 Before You Begin .....	11
3.2 Mounting Location.....	11
3.3 Procedure .....	13
<b>Section 4, Installing the Fuel System</b> .....	<b>15</b>
4.1 Before You Begin .....	15
4.2 Fuel System Installation .....	15
4.3 What NOT to Do .....	16
4.4 Procedure .....	17
<b>Section 5, Wiring the Electrical System</b> .....	<b>19</b>
5.1 Before You Begin .....	19
5.2 12 VDC .....	19
5.3 Remote Operating Panel Cable.....	20
5.4 Main Electronic Control Board .....	20
5.5 What NOT to Do .....	20
<b>Section 6, Plumbing the System</b> .....	<b>23</b>
6.1 Before You Begin .....	23
6.2 Plumbing Installation.....	23
6.3 What NOT to Do .....	25
6.4 Installation Procedure.....	25
<b>Section 7, Operating The WindowWasher™</b> .....	<b>27</b>
7.1 Operating Instructions.....	27
7.2 Turning the Power "ON" .....	28
7.4 Functions of the Remote Panel.....	28
7.5 Functions of Control Panel.....	29

7.6	WindowWasher Maintenance.....	31
7.7	Protect the WindowWasher™ .....	33
7.8	General Troubleshooting .....	33
<b>Section 8, Warranty Information.....</b>		<b>35</b>

## List of Figures

Figure 1-1: WindowWasher Unit .....	1
Figure 2-1: Dimensions .....	9
Figure 2-2: Location of Mounting Brackets.....	10
Figure 3-1: Installing the Exhaust System.....	14
Figure 5-1: System Wiring .....	20
Figure 6-1: Plumbing Fittings .....	23
Figure 7-1: The WindowWasher - Fittings.....	27
Figure 7-2: Remote Operating Panel.....	29
Figure 7-3: The WindowWasher - Control Panel.....	30

# Overview

Some of the figures in this manual represent a typical installation, but other configurations or methods may be acceptable. If in doubt, obtain approval from Calcutt Boats or ITR.

Thank you for purchasing The WindowWasher™ by ITR for the window cleaning trade.

This section describes features of The WindowWasher™ by ITR and covers critical information you need to know before beginning the installation, including how to protect your warranty, and tools and equipment needed.



Figure 1-1: WindowWasher Unit

## 1.1 Unpacking the WindowWasher

When you receive The WindowWasher™ by ITR:

- 1 Unpack it carefully.
- 2 Check each component against the provided parts list to ensure that you have everything and that all parts arrived undamaged.
- 3 If you discover any missing or defective parts, call Calcutt Boats or ITR immediately.
- 4 If you are not installing The WindowWasher™ by ITR right away, secure all components so none will be misplaced.
- 5 **Before installing The WindowWasher™ by ITR, read the rest of *Section 1 – Overview*. It contains critical information for a proper installation.**

A properly installed WindowWasher™ by ITR is essential for several reasons:

- To ensure that you and/or your customers receive satisfactory results.
- To ensure a trouble-free installation, a successful inspection and testing process and ease of future maintenance.
- To protect your Warranty.

## 1.2 Protect Your Warranty

This document reflects approved installation techniques, methods, and materials, and applies only to ITR equipment. The WindowWasher™ by ITR is only guaranteed by ITR if the entire system has been installed according to the requirements and recommendations set out here.

**Any modification must be approved in writing by qualified Calcutt Boats or ITR personnel, prior to the installation.**

This includes:

- Deviations from the instructions in this Manual.
- Changes to any piece of ITR-supplied equipment.
- Substitution of a non-ITR-approved component.

NOTICE

No warranty will be extended to improper installations. Use of any unapproved materials, equipment, or installation procedures will result in a voided warranty for the entire system. Calcutt Boats and ITR accept no liability for any damage or loss of service resulting from unapproved modifications.

---

- Efficient
- Clean
- Quiet
- Compact
- Safe
- Rugged
- Reliable
- Economical

### 1.3 The WindowWasher™ by ITR Features

The WindowWasher™ by ITR uses a patented diesel burner (12 VDC) controlled by a multi-functional electronic controller as the primary source of heating water. The WindowWasher™ by ITR heats water to provide a continuous supply for window cleaning.

Other features of The WindowWasher™ by ITR include:

- A high-temperature, stainless steel burner and stainless steel jacket.
- 5.3 US gallon (20.5 L) welded stainless steel insulated water tank that minimizes heat loss and optimises heat recovery.
- Low water level switch in the tank.
- Easy to install with hook-ups and connections easily accessible from the top and front of The WindowWasher™ by ITR.
- Quiet operation and low power consumption.
- Low pressure fuel system with built-in fuel pump.
- Fuel efficient burner capable of burning a wide variety of diesel-based fuels.
- Exhaust has minimal smoke or smell.
- Fan assisted sealed combustion chamber is designed to use outside air.
- Simple, low amperage draw ignition.
- Electronically-controlled system with:
  - Automatic Safety Shutdown.

- Manual reset aquastats for safety overheat protection.
- LED indicators on the Control Panel for diagnostics.
- Patented, proprietary flame sensor.
- The WindowWasher™ by ITR Remote Operating Panel with ON/OFF switch for the diesel burner and indicator LEDs for operational and diagnostic information.

## 1.4 Critical Factors

Pay attention to the notices of "Danger" "Warning" "Caution" and "Notice" in this manual.

The key factors to keep in mind when planning and carrying out the installation are:

- Mounting location restrictions for The WindowWasher™ by ITR exhaust outlet (to reduce noise, vibration, heat loss, etc.)
- Length, routing, and sizing of fluid lines, fuel lines, air flow tubing, exhaust piping and wiring.
- Unrestricted intake required to draw in outside air for combustion.
- Ability to easily access and service the product, especially fuel, plumbing, and electrical systems.
- After installation, requirement to purge water and fuel lines and inspect/test entire system using the ITR-supplied Inspection Check Sheet.

## 1.5 Equipment, Tools and Skills

As the user and/or installer, you must be qualified and authorized to do the installation, which requires mechanical aptitude and electrical knowledge. Make sure you comply with existing industry practices, using the highest and most recent standards and codes. Good workmanship is essential. Please refer back to *Section 1.2, Protect Your Warranty*.

You will need the following equipment and tools (not supplied) to install the heating system. This list does not include optional equipment and accessories:

- Standard tools normally available in a well-equipped workshop.
- Appropriate fasteners for mounting the heater unit.

- Stainless steel 1-1/2" ID exhaust piping, maximum 12' with no bends (see *Section 3 – Installing the Exhaust System*, for details when bends are present).
- Optional ITR silencer.
- 1/4" supply and return fuel line, approved rubber or copper.
- Domestic water hose and/or tubing to connect The WindowWasher™ by ITR hose fittings to the van water system.

## 1.6 Testing and Inspection

After all components have been properly installed according to standard practices, and the recommendations of this Installation and Operating Manual, The WindowWasher™ by ITR should be test-operated for inspection purposes.

For your convenience, you can use the pullout *Inspection Check Sheet* in this Manual. The Inspection Check Sheet is divided into progressive sections, allowing each phase of the inspection to be carried out systematically, and then signed off by authorized persons.



# Mounting the WindowWasher



## 2.1 Before You Begin

Plan the location of The WindowWasher™ by ITR and all its major components in advance to ensure the chosen locations are feasible and within the technical specifications.

Consider the following factors to help you decide exactly where best to mount The WindowWasher™ by ITR:

- The WindowWasher™ by ITR weight when full.
- Ventilation requirements.
- Exhaust outlet location and maximum acceptable length.
- Through van body exhaust location.
- Potential for vibration and jarring.
- Fuel storage location.
- Most efficient plumbing runs.
- Safe and convenient access for maintenance.
- Location of other equipment to be installed or connected to The WindowWasher™ by ITR.

### ! WARNING

---

Make sure you are familiar with *Section 1 – Overview* of this Manual. If the system is not installed according to specifications and with the correct equipment, The WindowWasher™ by ITR may not operate properly, safety may be compromised, and your Warranty may be voided.

---



## 2.2 Your Mounting Location

Your mounting location should consider the following:

- Mounting location must be able to support double the gross weight of The WindowWasher™ by ITR (i.e. 150 lbs. x 2 = 300 lbs/68 KG x 2 = 136 KG) and must be of a non-combustible surface.
- The WindowWasher™ by ITR is 14"H x 14"W x 24"D (35.6 cm x 35.6 cm x 60.9 cm). See *Figure 2-1: Dimensions*.

### ! CAUTION

---

The WindowWasher™ by ITR must not be installed in any compartment with flammable gasses.

---

- The WindowWasher™ by ITR must be completely isolated from living spaces. Combustion air must be drawn from a 100% outside source and cannot contain any combustible gasses.
- The WindowWasher™ by ITR must be mounted in an area that provides unrestricted access to the front panel mounted fuel and water connections, and top mounted power and exhaust connection (minimum of 10" top clearance) and 3" clearance to all other WindowWasher™ surfaces.
- The WindowWasher™ by ITR must not be installed in any compartment with flammable gasses.
- The WindowWasher™ by ITR must be mounted horizontal and level using eight (8) x 1/4" through bolts using 1" diameter washers, lock washers and nuts.
- It is recommended that a catch tray be placed under The WindowWasher™ by ITR for containing any unexpected leakage.

### NOTICE

---

If The WindowWasher™ by ITR is going to be mounted in the engine compartment, check for adequate ventilation. When the engine is running, this area could be under a negative pressure. Make sure the air intake and exhaust hoses have no leaks and are well-fastened to the heater, silencer and through van fitting. Assembly parts that may cause injury through accidental contact should be protected.

---

---

Isolate the unit in a closed compartment so that no air from the heater will infiltrate the vehicle cab.

---

- Choose a sturdy surface in a location that won't be unduly affected by vibration and the jarring of rough roads.
- Mount the unit with the front panel side facing out and accessible. Facing out simplifies installation and maintenance.
- Open access is required to properly service the heater. Leave room at the **front**, and **top** of the unit.
- Ensure that the exhaust tubing can be properly and safely routed to the outside. The maximum exhaust run for the system is 12'.

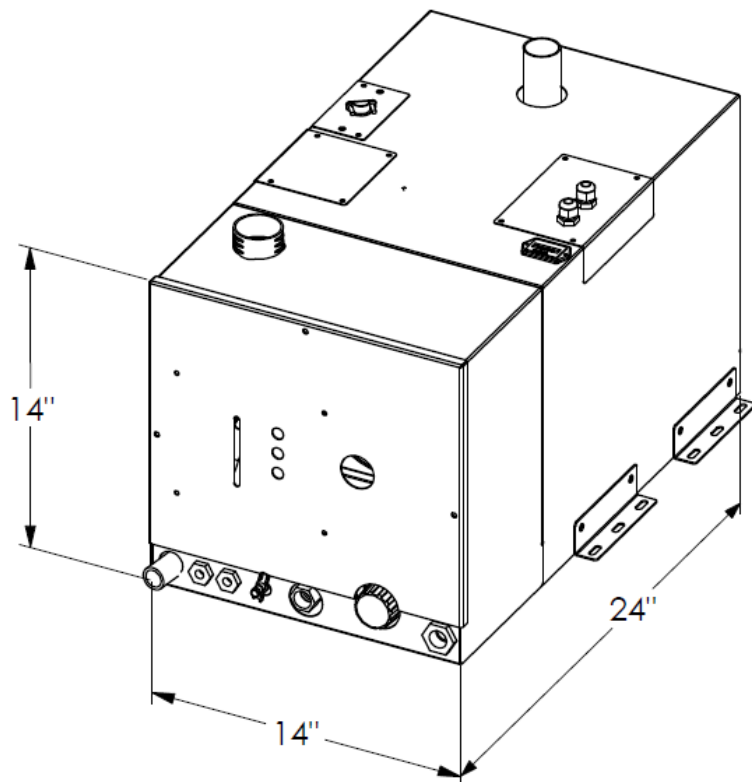

Figure 2-1: Dimensions



## 2.3 Procedure

After choosing the mounting location for The WindowWasher™ by ITR:

- 1 Mount The WindowWasher™ by ITR horizontally and level.
- 2 Secure The WindowWasher™ by ITR in place (against the wall, floor, or a mounting platform) using eight (8) x 1/4" through bolts using 1" diameter fender washers, lock washers and nuts (See *Figure 2-2: Location of Mounting Brackets.*).

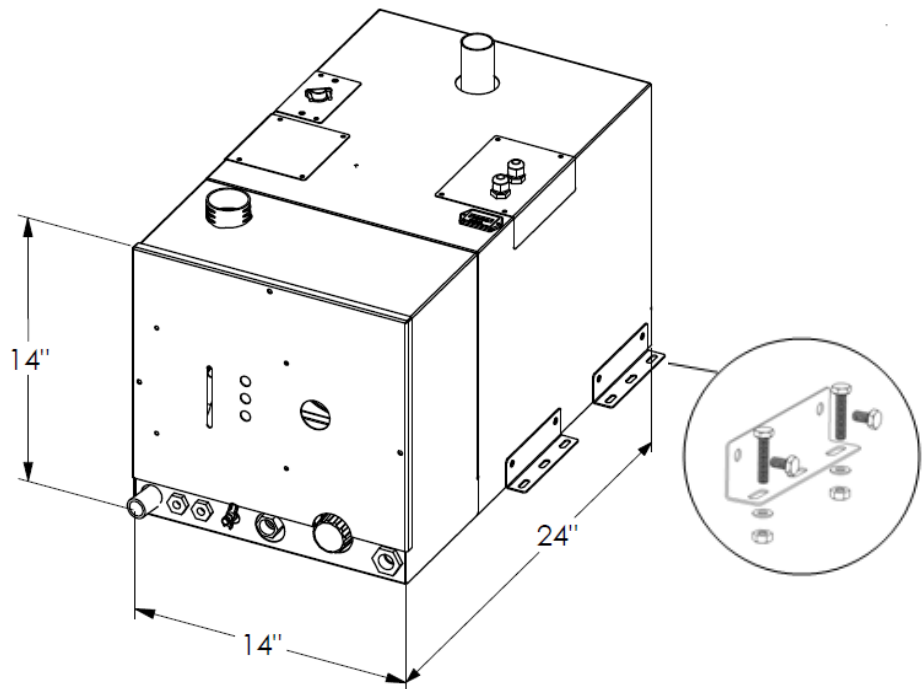

Figure 2-2: Location of Mounting Brackets

# Installing the Exhaust System



## 3.1 Before You Begin

For efficient and safe operation of The WindowWasher™ by ITR follow all recommendations for properly installing the exhaust. Any deviations from these must be approved in advance by Calcutt Boats or ITR.

**! DANGER**

---

Although the heater's exhaust produces very low carbon monoxide emissions, caution is still advised:

- Do not operate The WindowWasher™ by ITR in an enclosed area unless there is adequate ventilation.
- Isolate The WindowWasher™ by ITR in a closed compartment so that no air from the unit will infiltrate the vehicle cab.

Never place any exhaust parts close to combustible material or through a combustible wall or ceiling without fireproof protection. The exhaust can reach high temperatures.

---

## 3.2 Mounting Location

If you can't meet the technical specifications for mounting the exhaust, don't use The WindowWasher™ by ITR. The unit may perform poorly or become damaged if not installed according to specifications.



### Recommended Exhaust Outlet Locations

The following is recommended for a van exhaust outlet location:

Mount the exhaust outlet **outside** the van, not inside the heater compartment. Otherwise, exhaust fumes could infiltrate the van from The WindowWasher™ by ITR compartment.

In a van, the typical mounting location for the exhaust outlet is under the floor of the heater compartment, or on the other side of the van, directly across from the heater unit. Keep in mind you cannot exceed 12' of exhaust piping, including bends.

Position the outlet of the exhaust pipe so that the exhaust exits off the side of the van, not towards the front, back, or under an opening window, vent or slide-out.



### Recommendation for Installation

You may use sweep bends but each 90° bend is equivalent to one foot of exhaust piping. For example, if you use two 90° bends you must deduct one foot per bend from the maximum allowed 12' straight exhaust pipe length. Therefore you will be restricted to 10' of straight exhaust piping plus the two bends. Do not exceed these recommendations.

The combustion air-intake must use 100% outside air.

Use an ITR-manufactured silencer; no other silencer is acceptable.

Exhaust outlet is on the top of The WindowWasher™ by ITR, towards the back.

**! DANGER**

---

The exhaust and outlet are HOT and the surrounding areas must be thermally shielded and protected from the hot surfaces and heat build-up by insulation. Nothing can come into inadvertent contact with any part of the exhaust system

---

Exhaust pipe must have a minimum of 3" (7.6 cm) clearance from all surfaces.

Ensure that the exhaust cannot be plugged or restricted.

The exhaust fitting on The WindowWasher™ by ITR is 1.5" O.D. and the exhaust pipe used must have a minimum of 1.5" I.D throughout its length.

All exhaust elbows must be of a large radius design (minimum radius 2.0").

The exhaust must be supported a minimum of every 3' of its installed length.

The exhaust and The WindowWasher™ by ITR connection point must use appropriate clamps and sealing compound to ensure that the connections are tight and leak free. The WindowWasher™ by ITR exhaust outlet pipe and the exhaust pipe itself must not be distorted or damaged during this process.

With The WindowWasher™ by ITR running, the connection points and the system must be checked for leaks and any found must be corrected. Periodically, check the exhaust fittings, connections, exhaust tube and insulation for leaks and integrity and correct if required.

Appropriate exhaust insulation must be used to cover the entire length of any interior exhaust run.

Solid stainless steel exhaust tubing is recommended but an approved stainless steel flexible exhaust tubing can be used. If flexible exhaust tubing is used the exhaust tubing must be inspected regularly for leaks and deterioration as this type of exhaust does not have the life expectancy of solid tubing. Stepped band clamps are recommended for joining flex and solid tubing as they apply firm, even pressure.

- Install an exhaust collar on the exhaust pipe to isolate the pipe from the van.



#### What NOT to Do

**Don't** mount the exhaust pipe inside the heater compartment.

**Don't** use more than 10' of exhaust pipe including no more than 180° of total bends.

**Don't** use silencers with any flow restrictions.

**Don't** over tighten exhaust clamps or you may crush The WindowWasher™ by ITR's exhaust spout.



### 3.3 Procedure

Figure 3-1 shows a standard setup for the up exhaust. To install the exhaust system:

- 1 Leave suitable air spacing to protect combustible materials; use an exhaust collar and metal shields where required.
- 2 Securely seal the exhaust piping to The WindowWasher™ by ITR fitting using an approved exhaust clamp.

## Section 4, Installing the Fuel System

- 3 Connect the exhaust piping in series with the silencer, using heavy-duty exhaust clamps. If you use vibration isolation mounts they must be high temperature.
- 4 Connect the air-intake tubing (2" I.D.) to the air-intake fitting on top of the heater, and to an outside air-intake fitting. Ensure the run of tubing is as short as possible to facilitate air flow.
- 5 Secure both ends of the air-intake tubing with properly sized hose clamps to prevent air leaks.
- 6 Make sure the air-intake and exhaust hoses have no leaks and are not touching each other.

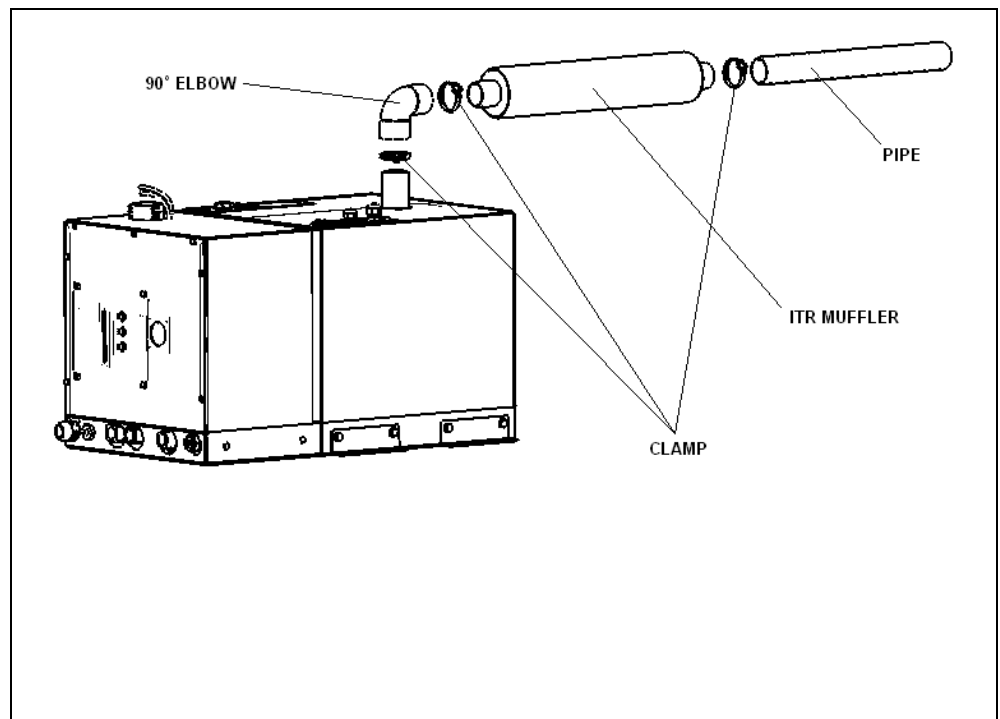
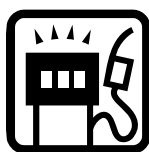

Figure 3-1: Installing the Exhaust System

# Installing the Fuel System



## 4.1 Before You Begin

For efficient and safe operation of The WindowWasher™ by ITR, follow all recommendations for properly installing the fuel system. Any deviations from these recommendations must be approved in advance by Calcutt Boats or ITR.

### ! DANGER

---

Never use petrol in The WindowWasher™ by ITR. Use only diesel fuel, furnace oil, stove oil or kerosene.

Keep fuel lines away from any heat source above 100°F (38°C).

Keep petrol and any equipment that uses petrol away from The WindowWasher™ by ITR location. The WindowWasher™ by ITR is not rated for use in an explosive environment.

### ! WARNING

---

Never share the fuel supply to The WindowWasher™ by ITR with any other fuel-burning device.

---

## 4.2 Fuel System Installation



### Recommendation for Installation

The WindowWasher™ by ITR's fuel connections are accessed from the front panel of the heater. The fuel inlet and fuel return are labelled and located on the front lower face of The WindowWasher™ by ITR and are not interchangeable. These fittings consist of 1/8" female NPT that connect to the fuel pump inside the units' front cover.

The following is recommended for the fuel system installation:

**The fuel supply requires a dedicated pickup line from the main fuel tank.** The pickup must allow the heater to run out of fuel before the tank itself is empty.

The fuel supply from the fuel storage tank to the fuel inlet must be from a dedicated fuel pickup on the top of the tank.

- The fuel supply line should be installed with minimal rise from the fuel tank. In no event should The WindowWasher™ by ITR be more than 60" above the fuel tank.
- The fuel return line should be installed from The WindowWasher™ by ITR to the fuel tank.
- The fuel line must be run and secured so as to prevent damage, chafing and kinking during normal operation.
- All fuel line connection points and hoses must use suitable clamps and/or sealant and must be checked for leaks on the initial installation and also periodically as part of normal maintenance.
- A primary fuel oil filter (not provided) must be installed inline in the fuel supply hose between the tank and The WindowWasher™ by ITR, in a manner that ensures easy access for maintenance. A secondary fuel filter is mounted inside The WindowWasher™ by ITR case. Both filters must be inspected and replaced as required as part of normal maintenance.
- Fuel line hose used must be appropriate for your requirements. It is strongly recommended that the hoses have permanently installed end fittings.



### 4.3 What NOT to Do

**Don't** allow the fuel or the fuel lines to become contaminated with foreign material.

**Don't** allow the fuel lines to become damaged or constricted.

Ensure that fuel lines are always protected from contamination by foreign material. When installing or servicing, seal off ends to prevent contamination. After installing, you may also wish to flush the fuel line to rid it of air and any foreign material.

---

**! CAUTION**

---

Be sure that all fuel lines are secured and will not become pinched, kinked or damaged during normal operation.

---



## 4.4 Procedure

To complete the fuel system installation:

- 1** Install the inline fuel filter. The optimal location is on a compartment wall next to The WindowWasher™ by ITR, inline between the fuel tank and The WindowWasher™ by ITR.
- 2** Connect the fuel line to the dedicated fitting on the main diesel fuel tank.
- 3** Inspect the supply and return fuel line for any loose connections or damage. Fittings must be airtight.
- 4** If desired, install a shut-off valve on the tank side of the fuel filter to allow shutdown and filter service.

## Section 4, Installing the Fuel System

# Wiring the Electrical System



## 5.1 Before You Begin

The WindowWasher™ by ITR and its electrical Control Board are pre-wired and have been thoroughly tested together as a unit.

To review the wiring system for The WindowWasher™ by ITR, refer to the schematic in this *Section 5, Figure 5-1: System Wiring*.

### ! WARNING

---

All electrical connections and wiring must comply with normally-accepted 12 VDC wiring practices and local regulations. Only a qualified electrical installer should complete the wiring.

---

## 5.2 12 VDC

The following apply to the 12 VDC connections to the The WindowWasher™ by ITR:

- There is one paired set of 12 VDC electrical connections on the top right of The WindowWasher™ by ITR. They consist of the primary DC positive (red) and negative (black) connection and are 14 gauge stranded copper wires.

### ! WARNING

---

Primary DC power should originate from a dedicated connection to an auxiliary battery. A 20 amp fuse or breaker must be included inline from the battery to the positive (red) connection on The WindowWasher™ by ITR. The primary power wire gauge must be sized to permit no more than a 3% voltage drop from the battery to The WindowWasher™ by ITR.

---

- A properly-shielded power system is required for safe, trouble-free operation.

### 5.3 Remote Operating Panel Cable

- The other connection on the top right of The WindowWasher™ by ITR is a short four (4) wire remote operating panel cable with a four (4) pin connector. This connects to a matching 25' connector cord that plugs directly into the Remote Operating Panel. Refer to *Figure 6-1: System Wiring*.

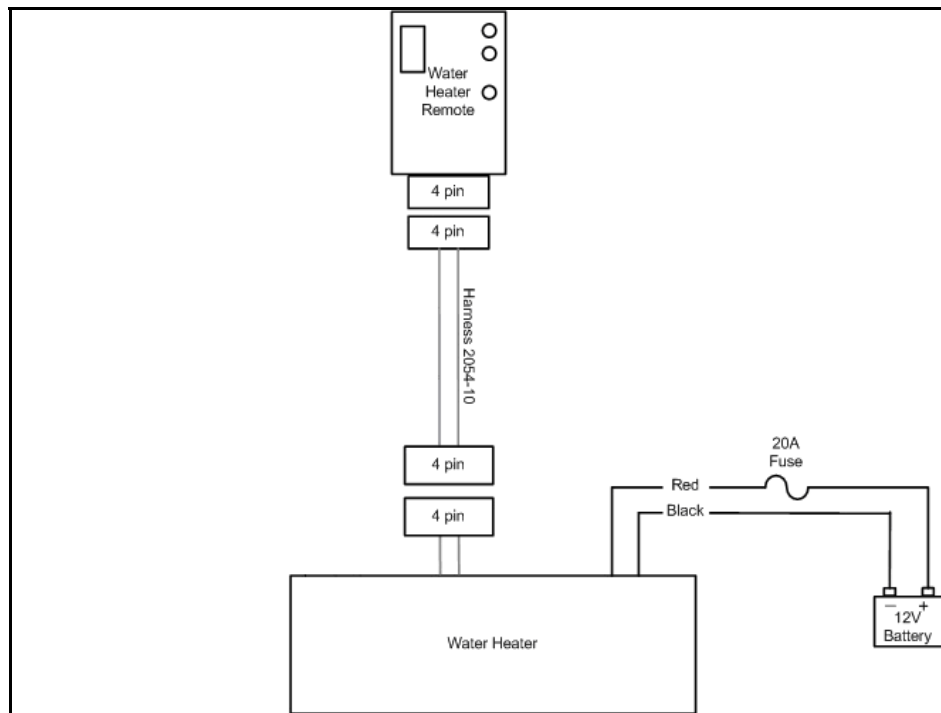

Figure 5-1: System Wiring

### 5.4 Main Electronic Control Board

- The main electronic Control Board is mounted on board The WindowWasher™ by ITR itself. It has no user adjustable components.



### 5.5 What NOT to Do

**NOTICE**

**Never** shut off The WindowWasher™ by ITR power via an inline battery or master switch while the system is running. Never disconnect the battery when The WindowWasher™ by ITR is running, and never disconnect the battery while the inverter is charging.

---

Doing either will severely damage The WindowWasher™ by ITR because it fails to automatically purge the combustion chamber. Such damage is detectable upon inspection and will *not* be covered under warranty. Always shut the system off using the normal system controls, after it has completed its purge.

---



# Plumbing the System

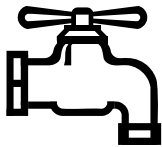

## 6.1 Before You Begin

For efficient and safe operation of The WindowWasher™ by ITR, follow all recommendations for properly installing the plumbing system. Any deviations from these must be approved in advance by Calcutt Boats or ITR.

## 6.2 Plumbing Installation

### NOTICE

Do not operate The WindowWasher™ by ITR until water is in the WindowWasher™ and heating system, and all trapped air has been bled.

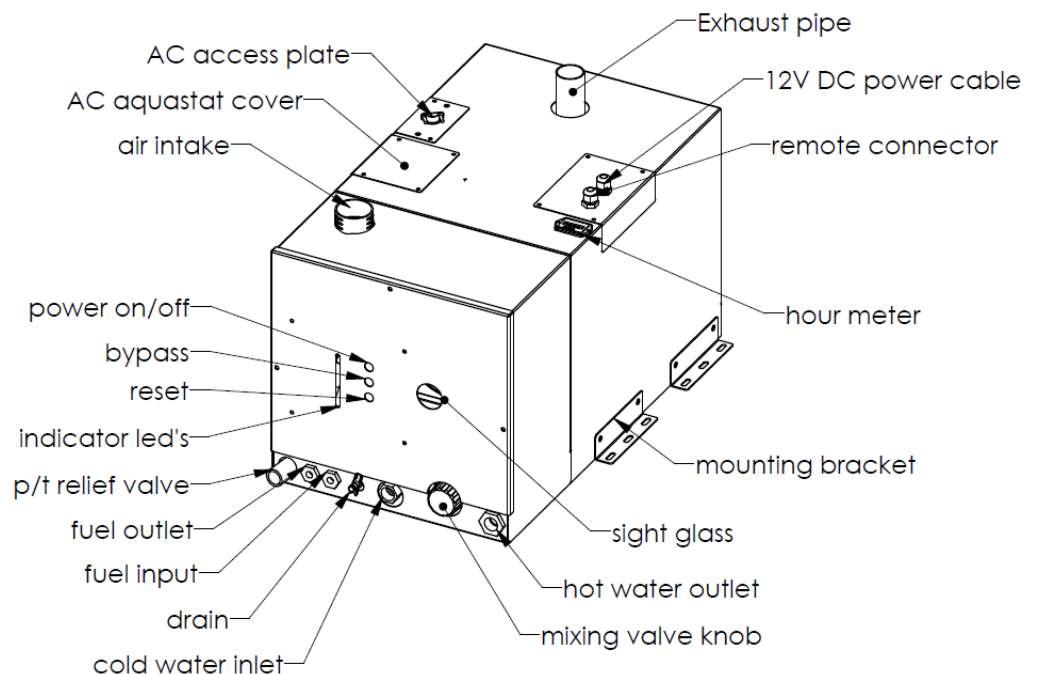

**Figure 6-1: Plumbing Fittings**

The plumbing installation should consider the following:

**NOTICE**

All fittings on the WindowWasher™ require two wrenches when tightening.

**NOTICE**

All fittings, hose and/or tubing involving the domestic water component of the distribution module (optional) must be approved for use with domestic water.

- All fittings on The WindowWasher™ by ITR require two wrenches when tightening. One wrench must be placed on the tank fitting and held in place to prevent this fitting from being overstressed. The other wrench can be used to tighten the matching half of the fitting onto it. Failure to follow this procedure will damage The WindowWasher™ by ITR and the fittings.
- All fittings, hose and/or tubing involving the domestic water must be approved for use with domestic water and rated for the domestic water system pressure. The working pressure limit of The WindowWasher™ by ITR tank is 150 psi.
- All plumbing lines must be run and secured so as to prevent damage, chafing and kinking.
- The WindowWasher™ by ITR should be filled and flushed prior to operation to remove any foreign debris.
- The WindowWasher™ by ITR is supplied with a temperature/pressure relief valve and drain fitting. This valve drains through the drain relief hose located at an opening on the left front lower face of The WindowWasher™ by ITR and is labelled "Temp/Pressure Relief Valve". Do not block or plug the valve or the hose. See the label attached onto the drain relief hose for the proper utilization and routing of this hose (see next page).

**NOTICE**

The WindowWasher™ is supplied with a temperature and pressure relief valve and drain relief hose. This valve drains through the drain relief hose located at an opening on the left front lower face of the WindowWasher™ and is labelled "Temp/Pressure Relief Valve". Do not block or plug the valve or the hose. See the label attached onto the drain relief hose for the proper utilization and routing of this hose.

**NOTICE****CAUTION! THIS IS A DISCHARGE LINE!**

**IT IS CONNECTED TO THE COMBINATION TYPE TEMPERATURE AND PRESSURE SAFETY RELIEF VALVE AT THE TANK. PROPER INSTALLATION IS REQUIRED.**

Discharge line should terminate through plain (unthreaded) pipe with at least a 6" (152mm) air gap from a location where any discharge will be clearly visible. In no case may a discharge line be directly connected to a sewer line. No reducing coupling or other restriction shall be installed in the discharge line. The discharge line shall be installed to allow complete drainage of both the valve and the discharge line. The discharge line must be installed in a continuously downward direction and in a frost free environment. Water may drip from the discharge line. The discharge line must be left open to atmosphere. Discharge line material must conform to local plumbing codes or ASME requirements. Excessive length over 30' (9.14m), use of more than four elbows, or reducing discharge line size will cause a restriction and reduce the discharge capacity of the valve. The pressure relief valve is to be operated regularly to remove lime deposits and to verify that it is not blocked. Temperature and pressure safety relief valve should be inspected at least once every three years and replaced, if necessary. See tag attached to the valve for additional instructions.

**Heater hose** — PEX tubing. Slip-on foam insulation coverings may be used over the hose fittings to reduce heat loss. Secure all hose connections with spring clamps.

- **Air vents** — Air vents for the fluid circulation system are not supplied, but may be optionally installed to help bleed air from the system.

## 6.3 What NOT to Do

---

**Don't** use low-quality heater hose.

**Don't** let the hose come into contact with solvents, which may cause it to soften and swell. If there is any risk that solvents may contact the hose, insert it into PVC plastic tubing for protection.

---



## 6.4 Installation Procedure

To install and connect The WindowWasher™ by ITR and heater hose.

- 1 The supply and return plumbing connections are on the front lower face of The WindowWasher™ by ITR and are 1/2" female NPT fittings. The supply input is labelled "Cold Water Inlet" and the hot water output is labelled "Hot Water Outlet". Ensure proper direction of flow.
- 2 Two male 1/2" NPT PEX tube fittings (not supplied) must be fitted into the supply and return fittings and tightened to a leak free condition.

- 3** Connect the water holding tank to the Cold Water Inlet. In some installations, a check valve may have to be obtained and installed on the cold input line to The WindowWasher™ by ITR to prevent warm water from backfilling to the water storage tank. Check the appropriate standards and regulations. Ensure there are no kinks or sharp bends that might restrict the fluid flow. If bends are required for PEX tubing, fit the tubing into a plastic bend support. Do not use rubber heater hose for potable water plumbing.
- 4** Connect the hot water supply line to the Hot Water Outlet. Ensure there are no kinks or sharp bends that might restrict the fluid flow. If bends are required for PEX tubing, fit the tubing into a plastic bend support. Do not use rubber heater hose for potable water plumbing.
- 5** A drain point, labelled “Drain” is provided on the front lower middle face of The WindowWasher™ by ITR and consists of a thumb valve.
- 6** A suggested procedure for filling The WindowWasher™ by ITR is to close The WindowWasher™ by ITR drain valve, open the highest hot water fitting, open the valve to the cold water inlet to The WindowWasher™ by ITR and then allow to fill. Once the water is flowing in a steady stream from the hot water fitting, close the fitting.
- 7** To drain the WindowWasher™ by ITR, have the outlet of the pressure relieve valve and the outlet of the drain valve go into a bucket or to a drain where it will not create a mess. Open the drain valve and open the pressure relief valve and allow all of the water to drain from the tank. Once the water has been drained, close the pressure relief valve and the drain valve.

# Operating The WindowWasher™

## 7.1 Operating Instructions

This section describes the operation and maintenance of your new WindowWasher™ by ITR.

### NOTICE

The WindowWasher™ by ITR must be installed and connections made in accordance with the recommendations in the Installation and Operating Manual prior to operating The WindowWasher™ by ITR.

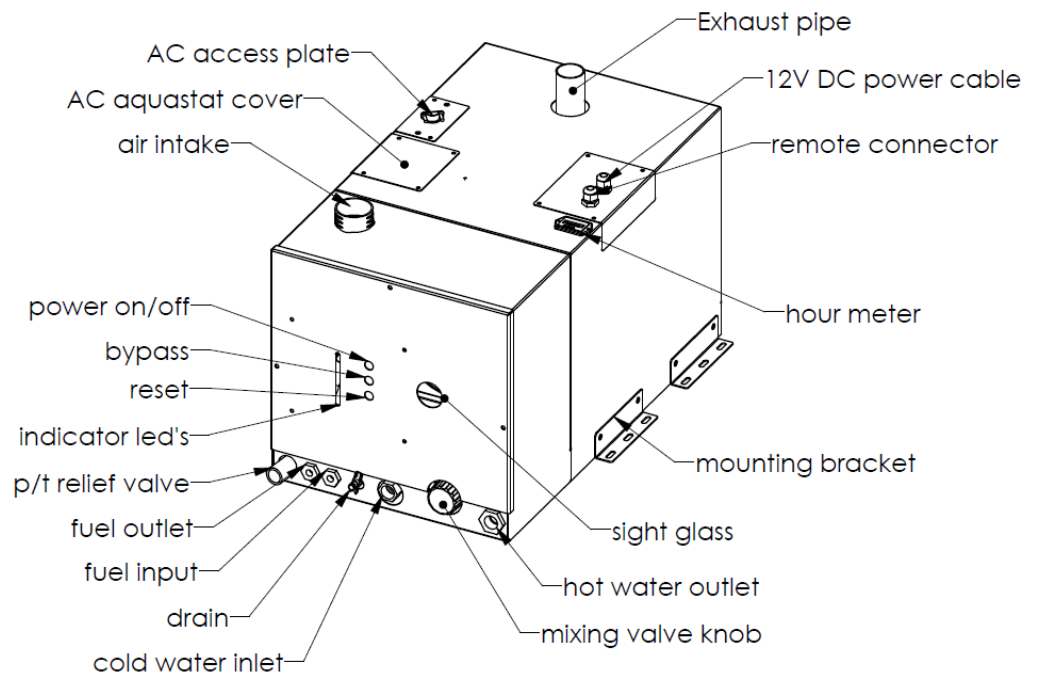

**Figure 7-1: The WindowWasher - Fittings**

## 7.2 Turning the Power “ON”

- The WindowWasher™ by ITR’s Control Panel located on the WindowWasher™ itself contains three push buttons: ON/OFF power, Bypass and Reset. The power switch must be pushed ON (power LED will turn ON) to turn the DC electrical power to the main Control Board and WindowWasher™ ON and is required to be left ON during any period where heat is requested. When The WindowWasher™ by ITR is shut down for any extended period or the season it is recommended that the power switch be turned OFF.

## 7.3 Activating the Burner (Primary)

### Activating the Burner (Primary Heat Source)

**NOTICE**  
Do not operate the WindowWasher until it is filled with water and all trapped air has been bled.

- The burner switch on the Remote Operating Panel controls the ON/OFF of the diesel burner (primary heat source). When the burner switch is turned ON, the diesel portion of The WindowWasher™ by ITR will turn on after ten seconds. The Burner LED on the Remote Operating Panel will turn ON when the diesel burner has been activated. The burner will continue to operate until the water in The WindowWasher™ by ITR reaches the set operating temperature range. At this point, the diesel burner will turn OFF. If The WindowWasher™ by ITR water should cool to outside of this temperature range, the burner will again come on and will continue until either the burner switch on the Remote Operating Panel is turned OFF or the temperature range is again achieved. If the burner switch on the Remote Operating Panel is turned OFF, the burner stops and The WindowWasher™ by ITR enters a two minute cool down stage prior to completely shutting down.

## 7.4 Functions of the Remote Panel

- The WindowWasher™ by ITR’s Remote Operating Panel, *Figure 7-2: Remote Operating Panel*, contains one ON/OFF burner switch and three LEDs indicating Burner activation, AC element activation, and service.

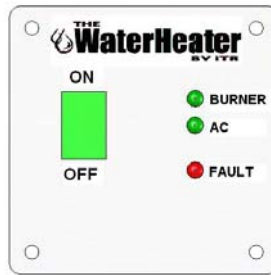

**Figure 7-2: Remote Operating Panel**

### **Burner Switch (Primary Heat Source)**

- The burner switch controls the ON/OFF of the diesel burner. The Burner LED will turn ON when the diesel burner has been activated.

### **Burner LED (Green)**

- When ON, indicates the diesel burner has been activated.

### **AC Heat LED (Green)**

- Not used.

### **Service LED (Red)**

- When ON, indicates The WindowWasher™ by ITR has faulted. The specific fault can be identified by examining the WindowWasher™ Control Panel located on the WindowWasher™. There are three red and six green indicator LEDs on this panel. Refer to the description of the WindowWasher™ Control Panel for further details.

## 7.5 Functions of Control Panel

The WindowWasher™ by ITR's Control Panel, *Figure 7-3: WindowWasher™ Control Panel*, contains three push buttons: ON/OFF power, Bypass and Reset. In addition, it contains nine LEDs indicating Power, Air Compressor, Fuel Pump, Combustion Fan, Igniter, Flame Fault, Voltage Fault and Low Water Level Fault.

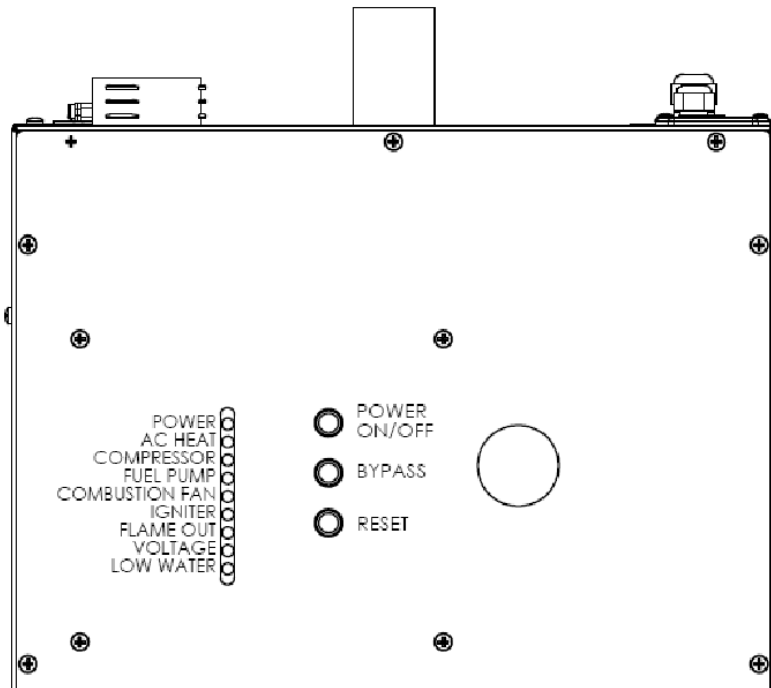

Figure 7-3: The WindowWasher - Control Panel

### Power On/off Button

- The *Power On/Off* button turns ON/OFF the power to the WindowWasher™ Control Board. The Power LED (green) turns ON when the power to the control board is ON.

### Bypass Button

- The *Bypass* button is for authorized service personnel only.

### Reset Button

- The *Reset* button when pressed resets the WindowWasher™ Control Board.

### Power LED (Green)

- The *Power* LED (green) turns ON when the power to The WindowWasher™ by ITR Control Board is ON. The LED flashes when the WindowWasher™ is in bypass mode.

**AC Heat LED (Green)**

- Not used.

**Compressor, Fuel Pump, Combustion Fan, Igniter LED (Green)**

- The air *Compressor, Fuel Pump, Combustion Fan* and *Igniter* LEDs (green) turn ON when the component is ON, and will flash if the component is electrically open or shorted.

**Flame Out LED (Red)**

- The *Flame Out* fault LED (red) turns ON when a flame fault has been detected.

**Voltage LED (Red)**

- The *Voltage* fault LED (red) turns ON when a voltage fault has been detected.

**Low Water LED (Red)**

- The *Low Water* level fault LED (red) turns ON when a low water level in the WindowWasher™ has been detected.

## 7.6 WindowWasher Maintenance

**Customer Monthly Maintenance:** Check the following and correct as required:

Water hoses and fittings for leaks and integrity.

Exhaust fittings, connections, tubes for leaks, and integrity.

Exhaust and air-intake checked for no obstructions.

Fuel lines, fittings for leaks and integrity.

External fuel filter for clogging.

**Annual Factory Maintenance:** Perform the following:

Factory Service Tune-up (DC power is disconnected):

Prior to operation for the season, a factory service tune-up of the modular system should be performed by trained service personnel. Only personnel familiar with the equipment modules should perform the service tune-up. It is recommended that the dealer be contacted for this service or if not available, contact Calcutt Boats or ITR for further instructions.

As a general guide, the regular maintenance items such as the igniter, fuel nozzle, fuel filters (internal and external) and air filter (internal) should be replaced as opposed to inspected and cleaned. Their performance may be

deteriorating and/or their remaining service life ending without any apparent visual signs or operating symptoms. The major components such as the air compressor, fuel pump, and combustion air fan should be examined for wear and should be replaced by the service technician as required. They are not serviceable and must be replaced. The combustion tube should be inspected by the service technician for wear and replaced if necessary. If the tube is satisfactory, a thorough cleaning of the tube and burner chamber should be performed. The domestic water mixing valve on the WindowWasher™ should be inspected every year and replaced if necessary. See the tag attached to the valve for additional instructions (see below).

This \_\_\_\_ Mixing Valve must be installed and adjusted per the supplied instruction sheet. It must be installed in accordance with applicable plumbing codes. To insure that the valve keeps working properly, periodically turn the handwheel a full number lower (higher) than the set number. If you do not detect a noticeable decrease (increase) in the discharge temperature, service the valve immediately. Otherwise, turn the handwheel back to the original setting.

This \_\_\_\_ valve was installed \_\_\_\_\_. The handwheel was set to number : \_\_\_\_\_. Any change in the setting to a higher number may raise the discharge temperature to an unsafe temperature which may lead to scalds.

The temperature and pressure safety relief valve on the WindowWasher™ should be inspected every year and replaced if necessary. See the tag attached to the valve for additional instructions (see below).

**DO NOT REMOVE THIS TAG FROM VALVE.**

**WARNING:**

**FAILURE TO COMPLY WITH THESE INSTURCTIONS REGARDING THIS VALVE CAN RESULT IN SERIOUS PERSONAL INJURY OR DEATH AND/OR SEVERE PROPERTY DAMAGE.**

**ANNUAL OPERATION OF T& P RELIEF VALVES**

**WARNING:** Following installation, the valve lever **MUST** be operated **AT LEAST ONCE A YEAR** by the water heater owner to ensure that waterways are clear. Certain naturally occurring mineral deposits may adhere to the valve, blocking waterways, rendering it inoperative. When the lever is operated, hot water will discharge if the waterways are clear. **PRECAUTIONS MUST BE TAKEN TO AVOID PERSONAL INJURY FROM CONTACT WITH HOT WATER AND TO AVOID PROPERTY DAMAGE. BEFORE** operating lever, check to see that a discharge line is connected to this valve, directing the flow of hot water from the valve to a proper place of disposal. If no water flows when the lever is operated, replacement of the valve is required. **TURN THE WATER HEATER “OFF”** (see instruction manual) **AND CALL A PLUMBER IMMEDIATELY.**

**REINSPECTION OF T & P RELIEF VALVES:**

**WARNING:** Temperature and Pressure Relief Valves should be inspected **AT LEAST ONCE EVERY THREE YEARS**, and replaced, if necessary, by a licensed plumbing contractor or qualified service technician, to ensure that the product has not been affected by corrosive water conditions and to ensure that the valve and discharge line have not been altered or tampered with illegally. Certain naturally occurring conditions may corrode the valve or its components over time, rendering the valve inoperative. Such conditions can only be detected if the valve and its components are physically removed and inspected. **Do not attempt to conduct an inspection on your own.** Contact your plumbing contractor for a reinspection to assure continuing safety.

**WARNING: FAILURE TO REINSPECT THIS VALVE AS DIRECTED COULD RESULT IN UNSAFE TEMPERATURE OR PRESSURE BUILD-UP WHICH CAN RESULT IN SERIOUS INJURY OR DEATH AND/OR SEVERE PROPERTY DAMAGE.**

If discharge occurs, **CALL A PLUMBER IMMEDIATELY**. Discharge may indicate that an unsafe temperature or pressure condition exists which requires immediate attention by a qualified service technician or licensed plumbing contractor.

SEE WATER HEATER INSTRUCTION MANUAL FOR ADDITIONAL INFORMATION REGARDING THE TEMPERATURE AND PRESSURE RELIEF VALVE.

See other side for important information

**WARNING:** To avoid water damage and/or scalding due to valve operation, a discharge line must be connected to valve outlet and run to a safe place of disposal. The discharge line shall be installed to allow complete drainage of both the valve and the discharge line. No reducing coupling or other restriction shall be installed in the discharge line. The discharge line must pitch downward from the valve and terminate with a 6" (152mm) air gap from an approved location or building drain. The discharge line must terminate through plain (unthreaded) pipe. Discharge line material must conform to local plumbing code or A.S.M.E. requirements. Excessive length – more than 30 feet (9.14m), use of more than four elbows or bends in discharge piping, or reduction of discharge line size will cause a restriction and reduce the discharge capacity of the valve. No shut-off valve should be installed between the relief valve and tank, or in the discharge line.

To ensure proper operation, this valve must be installed by a qualified service technician or licensed plumbing contractor in accordance with these instructions and local plumbing codes and standards.

**WARNING:**

**FAILURE TO COMPLY WITH THESE INSTRUCTIONS REGARDING THIS VALVE CAN RESULT IN SERIOUS PERSONAL INJURY OR DEATH AND/OR SEVERE PROPERTY DAMAGE.**

Combination temperature and pressure relief valves with extension thermostats must be installed so that the temperature-sensing element is immersed in the water in the top 6" (152mm) of the water storage tank. They must be installed either in the hot outlet service line or directly in a tank tapping. Valves must be located so as to assure isolation from flue gas heat or other ambient conditions that are not indicative of stored water temperature. See other instructions regarding the discharge line.

This device is designed for emergency safety relief and must not be used as an operating control.

Repair or alteration of valve in any way is prohibited by national safety standards/local codes.

Regular inspection and maintenance are a necessary part of a properly operating module and satisfactory performance.

## 7.7 Protect the WindowWasher™

Protect The WindowWasher™ by ITR from temperature extremes and any dusty, dirty, corrosive environment.

Protect The WindowWasher™ by ITR from cold temperatures and corrosion.

Note that any water in The WindowWasher™ by ITR will freeze in cold temperatures and will damage the components. The WindowWasher™ by ITR and all associated components must be completely drained of water and emptied before freezing temperatures are encountered.

## 7.8 General Troubleshooting

**Ensure that The WindowWasher™ by ITR has both sufficient battery voltage and water level as The WindowWasher™ is designed not to allow operation if either are incorrect (indicated by lit Voltage Fault or Low Water Level Fault LEDs on The WindowWasher™ Control Panel) .**

### **Burner Does Not Start Up**

WindowWasher™ connected to 12 VDC power?

*Power On/Off* button on WindowWasher™ Control Panel pushed ON?

*Power* LED lit on Remote Operating Panel?

Burner switch on Remote Operating Panel ON?

Fuses or circuit breakers blown or tripped?

**Burner Starts but Flame Faults**

Fuel supply present and adequate?

Air-intake or exhaust not blocked or obstructed?

Air in fuel line (White smoke from exhaust)?

Fuel filter (external) dirty?

Component LEDs all glowing green on The WindowWasher™ Control Panel?

# Warranty Information

## NOTICE

### Attention Purchaser and Installer

**No warranty covers damage or failure of the heater (“The Product”) or to the vehicle in which it is installed, due to unapproved, unauthorized, or improper installations of the Product. Use of any unapproved materials or equipment in the Product’s installation or operation will result in a voided warranty for the entire heating system.**

- You must install the Product in compliance with the specifications, standards, and instructions in the *Installation Manual*.
- If you need to depart from the manual, you must first consult and obtain the written approval of Calcutt Boats or ITR. Otherwise, your warranty may be voided or limited.
- Systems that are not installed to the published installation instructions (unless with prior written approval of Calcutt Boats or ITR) will be ineligible for warranty coverage.
- Fill in the enclosed Warranty Card completely. It must be completed by the Owner and returned to Calcutt Boats within 30 days of the date of the original installation. The Owner cannot transfer this warranty. Before mailing, make photocopies of the completed Warranty Card for your records. It will be a valuable reference if you need warranty repairs in the future.

## General Warranty

ITR warrants all water jackets or coolant jackets in the Products to be free of defects in materials and workmanship under design usage and service conditions for three (3) years from the date of the sale to the original retail owner or three thousand (3000) hours of operation of the Product, whichever comes first.

ITR warrants the water tank in the WindowWasher to be free of defects in materials and workmanship under design usage and service conditions for two (2) years from the date of the sale to the original retail owner or two thousand (2000) hours of operation of the Product, whichever comes first. All other accessories and components supplied or installed in the heater will be covered by the lesser of the accessory and component manufacturer's warranty or a period of two (2) years or two thousand (2000) hours from the date of the sale to the original retail owner of the Product. Warranty replacement parts are covered for the remainder of the Product's warranty or ninety (90) days, whichever is greater. At ITR's discretion, coverage for warrantable parts may be made to the Owner in the form of repair, replacement, or credit.

## Limited Warranty

The following warranties are in lieu of all other warranties and conditions. ITR makes no other warranties, representations, or conditions, express or implied. Expressly excluded are all implied or statutory warranties or conditions of merchantability of fitness for a particular purpose, and those arising by statute or otherwise in law or from dealing or trade usage.

The stated express warranties are in lieu of all liabilities or obligations for damages arising out of or in connection with the delivery, use, performance, or licensing of the Product or in connection with any services performed. In no event whatsoever will ITR be liable for indirect, consequential, exemplary, incidental, special, or similar damages, including but not limited to, lost profits, lost business revenue, failure to realize expected savings, other commercial or economic loss of any kind or any claim against ITR by any other party arising out of or in connection with the sale, delivery, use, performance, or repair of the Product, or in connection with any services performed, even if ITR has been advised of the possibility of such damages, whether based upon warranty, contract, or negligence. ITR's maximum liability shall not in

any case exceed the contract price for the Products claimed to be defective.

No one is authorized to increase, alter, or enlarge ITR's responsibilities or obligations under these warranties.

## Owner's Responsibilities

If any warrantable failures occur before the expiration of the warranty, the Owner must give notice of such failures to ITR or to the authorized ITR dealer from which the Product was originally purchased, and obtain written approval for the warranty repair.

The Owner is responsible for the following costs in case of a warrantable failure:

- shipping and insurance costs to deliver the defective Product to the dealer or ITR (if necessary)
- all repairs made to equipment ancillary to the Product, including the vehicle, engine, and other associated components of the vehicle in which the Product is installed
- lodging, meals, and other incidental expenses incurred by the Owner as a result of a warrantable failure
- "down time" expenses and all business costs and losses resulting from the warrantable failure

## Not Covered Under Warranty

Warranty will be voided or not extended in the following circumstances:

- Owner fails to notify ITR or the authorized ITR dealer from which the Product was originally purchased about a warrantable failure and to obtain prior written approval for warranty repair.
- Original serial number on Product or electrical control board has been removed, altered, or is unreadable.
- Product has been modified or uses non-standard parts not approved by ITR.
- Product has been abused (such as by dropping it), damaged, vandalized, or has received improper maintenance.
- Product has been run dry or operated without appropriate antifreeze; causing damage to the heat exchanger, pump seals, etc.

- Product has been exposed to an environment detrimental to its effective operation, such as excessively wet, dirty, or hot areas.

**Also not covered under warranty:**

- Parts or Products no longer within the manufacturer's warranty period.
- Parts or Products installed or used in a manner contrary to ITR's printed instructions without ITR's prior written permission.
- Normal wear and tear of parts, including but not limited to, fuel filter, air filter, nozzles, fuses, ignitor, electrical motors, fuel pumps, air compressors, and carbon brushes.
- Product malfunctions due to improper installation of parts or Products, including but not limited to malfunctions causing inadequacies in air, fuel, or coolant flow; voltage problems due to improper wiring; and shock or vibration.
- Progressive damage to the engine or vehicle caused by failure of the Product or an improper installation.
- Diagnosis or repairs to fix problems not directly related to the Product or due to empty fuel tanks or poor fuel quality, fuel additives, acidic water, electrolysis, or any chemical reactions.
- Travel time and expenses by an ITR dealer.
- Removal and re-installation expenses for the ITR heater.

## Customer Service Calls

ITR warrants the ITR heater and the Dealer warrants the installation.

If you have a service problem, first check the *Troubleshooting* section of the *Owner's Manual* to determine if your problem is addressed. Also ensure you are familiar with the design and installation setup.

When calling ITR or the Dealer with a service problem, have the following information ready at hand:

- model number and serial number of the Product
- a detailed description of the problem
- your *Installation Manual* and *Owner's Manual*

Depending on your location, an authorized service person may be able to visit your van to help troubleshoot problems

and repair your Product. Such service calls are at the Owner's expense. Regardless, you must obtain written approval from ITR or the Dealer for any warranty repair before it is undertaken. All repairs done under warranty are subject to the terms and conditions of the flat-rate manual.

## Returns

If a service call by an authorized service person is not feasible, the Owner must do the following to obtain warranty service:

1. Immediately contact ITR (or your Dealer) and provide a full description of the problem.
2. Obtain (in writing) a Return or Repair Material Authorization (RMA) number from ITR for any warranty, return, repair, or service. ITR will refuse any return package and will not authorize service or repairs without a RMA number. (For repairs by authorized Dealers, the dealer must obtain an authorized RMA number from ITR before warranty work commences.)
3. When shipping your Product, pack securely, show the RMA and serial number of the Product on the outside of the shipping container, and ship prepaid and insured.
4. Provide written details of the problems, date of installation, proof of purchase, and a return address.

After repair or replacement of the Products still under warranty, ITR will pay return shipping charges. Factory repairs or replacement will be done as quickly as possible, with an estimated turnaround of five working days. All repairs done under warranty are subject to the terms and conditions of the flat-rate manual.

## Telephone / Email Service

There is no charge for help or service information given over the telephone or by fax or email. However, any informal advice or recommendation from ITR employees or Dealers is given only in good faith as an accommodation to the customer. Such information should not be relied upon without an independent verification of its applicability to the customer's particular situation. For customer service or other information, contact:

**CALCUTT BOATS LTD**  
**Tomlow Road**  
**Stockton**  
**Southam**  
**CV47 8HX, UK**  
**Tel: +44 1926 813757**  
**Fax: +44 1926 814091**  
**Email: [info@dieselheating.com](mailto:info@dieselheating.com)**  
**Website: [www.dieselheating.com](http://www.dieselheating.com)**

## OWNER NOTES

WindowWasher Serial No:	
Installation Date:	
Installed by:	