

**INTERNATIONAL LTD
THERMAL RESEARCH**

The WaterHeater™ by ITR

Installation and Operating Manual

Continuous Domestic Hot Water Heater and Heating
System for Recreational Vehicles and Yachts

Copyright © June 2005

International Thermal Research

IN CANADA:

2431 Simpson Road

Richmond, BC, Canada V6X 2R2

Tel: 1-800-755-1272 or 604-278-1272

Fax: 604-278-1274

Email: itr@shaw.ca

IN THE UNITED STATES:

Suite 260, 600 SE Maritime Ave.

Vancouver WA USA 98661

Tel: 1-800-993-4402 or 360-993-4877

Fax: 360-993-1105

Email: info@itrheat.com

Website: <http://www.itrheat.com>

All rights reserved. No part of this manual may be reproduced or transmitted in any form by any means, electronic or mechanical, including photocopying and recording, information storage, retrieval, or transmission, without permission in writing from International Thermal Research

Right to Modify:

Due to our commitment for quality and ongoing product improvement, ITR reserves the right to modify or change without notice, any materials, applications, equipment, accessories, and/or prices. All measurements and weights are approximate.

Table of Contents

Section 1, Overview	1-1
1.1 Unpacking The WaterHeater™ by ITR.....	1-1
1.2 Protect Your Warranty	1-2
1.3 The WaterHeater™ by ITR Features	1-3
1.4 Critical Factors.....	1-4
1.5 Equipment, Tools and Skills	1-5
1.6 Testing and Inspection.....	1-6
Section 2, Mounting - The WaterHeater™	2-1
2.1 Before You Begin	2-1
2.2 Identifying The WaterHeater™ by ITR Model	2-2
2.3 Your Mounting Location.....	2-2
2.4 What NOT to Do.....	2-4
2.5 Procedure	2-5
Section 3, Installing the Exhaust System.....	3-1
3.1 Before You Begin	3-1
3.2 Mounting Location	3-1
Recommended Exhaust Outlet Locations.....	3-1
Recommendation for Installation	3-2
What NOT to Do.....	3-4
3.3 Procedure	3-4
Section 4, Installing the Fuel System	4-1
4.1 Before You Begin	4-1
4.2 Fuel System Operation.....	4-1
Recommendation for Installation	4-1
4.3 What NOT to Do.....	4-2
4.4 Procedure	4-3

Section 5, Installing Fan Heaters – With “Space heating Module” Only 5-1

- 5.1 Before You Begin 5-1
- 5.2 Fan System Operation 5-1
 - Features 5-2
 - Single Zone Heating 5-3
 - Accessories and Components Needed 5-3
- 5.3 What NOT to Do 5-4
- 5.4 Mounting Locations 5-4
- 5.5 Procedure 5-5

Section 6, Wiring the Electrical System 6-1

- 6.1 Before You Begin 6-1
- 6.2 12 VDC 6-1
- 6.3 120 VAC 6-2
- 6.4 Remote Operating Panel Cable 6-2
- 6.5 Main Electronic Control Board 6-3
- 6.6 Space Heating Control Board (optional) 6-3
- 6.7 What NOT to Do 6-4

Section 7, Plumbing the System 7-1

- 7.1 Before You Begin 7-1
- 7.2 Plumbing Installation 7-2
- 7.3 What NOT to Do 7-4
- 7.4 Installation Procedure 7-4

Section 8, Operating The WaterHeater™ by ITR 8-1

- 8.1 Operating Instructions for The WaterHeater™ by ITR 8-1
- 8.2 Turning the Power to The WaterHeater™ by ITR ON 8-2
- 8.3 Activating the Burner (Primary) 8-2
- 8.4 Activating the Cabin Fan Heaters through the Thermostats 8-3
- 8.5 Functions of the Remote Operating Panel 8-3
- 8.6 Functions of The WaterHeater™ by ITR Control Panel 8-4

8.7	Functions of the Space Heating Module (Optional) Zone Control Board.....	8-6
8.8	Maintenance.....	8-7
8.9	Protect The WaterHeater™ by ITR™ and Space Heating Module (Optional).....	8-10
8.10	General Troubleshooting	8-10

**Section 9, Installing The Space Heating Module
(Optional) 9-1**

9.1	Before you Begin.....	9-1
9.2	Identifying Your Space Heating (Optional) Model	9-2
9.3	Your Mounting Location.....	9-2
9.4	Selecting the Space Heating Module Zone Box Location.....	9-3
9.5	Plumbing Installation	9-3
9.6	Electrical Connection	9-7
9.7	Space Heating Zone Board	9-7
9.8	What NOT to Do.....	9-10
9.9	Procedure	9-10
9.10	INSPECTION AND TESTING	9-10

Section 10, Warranty Information

List of Figures

Figure 1-1	Hot Water Heater and Space Heating Module (Optional)	1-1
Figure 2-1	Dimensions	2-4
Figure 2-2	Location of Mounting Brackets Insets: Bracket/Nut/Bolt Configurations.....	2-5
Figure 3-1	Installing the Exhaust System (Up Exhaust) ...	3-5
Figure 3-2	The Exhaust Goose Neck Configuration.....	3-5
Figure 5-1	Wiring the Fan's Aquastat	5-2
Figure 5-2	Mounting a Spacesaver Fan	5-5
Figure 5-3	Installing a Relay for Add'l Fan Amperage	5-6
Figure 6-1	System Wiring	6-3
Figure 7-1	Plumbing Fittings.....	7-2
Figure 7-2	The Approved Method of Installing Heater Hose (Consult ITR for Alternative Methods and Products)	7-5
Figure 8-1	The WaterHeater™ by ITR – Fittings	8-1
Figure 8-2	Remote Operating Panel.....	8-3
Figure 8-3	The WaterHeater™ by ITR – Control Panel	8-5
Figure 9-1	Space Heating Module Plumbing Fittings	9-3
Figure 9-2	Space Heating Module and Hot Water Heater Hookup.....	9-5
Figure 9-3	Space Heating Module and Zone Board Electrical Hookup.....	9-8

Overview

Thank you for purchasing The WaterHeater™ by ITR for recreational vehicles and marine yachts.

Some of the figures in this manual represent a typical installation, but other configurations or methods may be acceptable. If in doubt, obtain approval from ITR.

This section describes features of The WaterHeater™ by ITR and covers critical information you need to know before beginning the installation, including how to protect your warranty, and tools and equipment needed.



1.1 Unpacking The WaterHeater™ by ITR

When you receive The WaterHeater™ by ITR:

- 1 Unpack it carefully.

- 2 Check each component against the provided parts list to ensure that you have everything and that all parts arrived undamaged.
- 3 If you discover any missing or defective parts, call ITR immediately.
- 4 If you are not installing The WaterHeater™ by ITR right away, secure all components so none will be misplaced.
- 5 **Before installing The WaterHeater™ by ITR, read the rest of *Section 1 – Overview*. It contains critical information for a proper installation.**

A properly installed WaterHeater™ by ITR is essential for several reasons:

- To ensure that you and/or your customers receive satisfactory results.
- To ensure a trouble-free installation, a successful inspection and testing process and ease of future maintenance.
- To protect your Warranty.

1.2 Protect Your Warranty

This document reflects approved installation techniques, methods, and materials, and applies only to ITR equipment. The WaterHeater™ by ITR is only guaranteed by ITR if the entire system has been installed according to the requirements and recommendations set out here.

NOTICE

Any modification must be approved in writing by qualified ITR personnel, prior to the installation.

This includes:

- Deviations from the instructions in this Manual.
- Changes to any piece of ITR-supplied equipment.
- Substitution of a non-ITR-approved component.

No warranty will be extended to improper installations. Use of any unapproved materials, equipment, or installation procedures will result in a voided warranty for the entire heating system. ITR accepts no liability for any damage or loss of service resulting from unapproved modifications.

- Efficient
- Clean
- Quiet
- Compact
- Safe
- Rugged
- Reliable
- Economical

1.3 The WaterHeater™ by ITR Features

The WaterHeater™ by ITR uses a patented diesel burner (12 VDC) controlled by a multi-functional electronic controller as the primary source of heating water. A single 1500 watt, 120 VAC immersion element is used as a secondary heat source (240 VAC also available). The WaterHeater™ by ITR heats water to provide a continuous supply for all domestic hot water needs. The WaterHeater™ by ITR can also provide a single zone of space heating using the Space Heating Module (optional). See Figure 1-1.

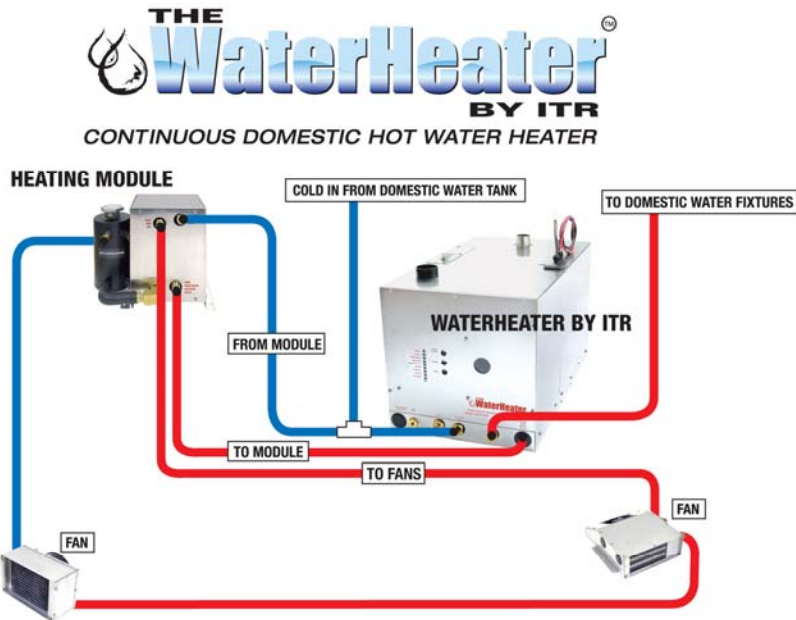

ITR INTERNATIONAL THERMAL RESEARCH
All rights Reserved - 11/2004

Figure 1-1: Hot Water Heater and Space Heating Module (Optional)

Other features of The WaterHeater™ by ITR include:

- A high-temperature, stainless steel burner and stainless steel jacket.
- 5.3 US gallon (20.5 l) welded stainless steel insulated water tank that minimizes heat loss and optimizes heat recovery.
- Low water level switch in the tank.
- Easy to install with hookups and connections easily accessible from the top and front of The WaterHeater™ by ITR.
- Quiet operation and low power consumption.
- Low pressure fuel system with built-in fuel pump.
- Fuel efficient burner capable of burning a wide variety of diesel-based fuels.
- Exhaust has minimal smoke or smell.
- Fan assisted sealed combustion chamber is designed to use outside air.
- Simple, low amperage draw ignition.
- Electronically-controlled system with:
 - Automatic Safety Shutdown.
 - Manual reset aquastats for safety overheat protection.
 - LED indicators on the Control Panel for diagnostics.
 - Patented, proprietary flame sensor.
- The WaterHeater™ by ITR Remote Operating Panel with ON/OFF switch for the diesel burner and indicator LED's for operational and diagnostic information.

1.4 Critical Factors

Pay attention to the notices of "Danger" "Warning" "Caution" and "Notice" in this manual.

The key factors to keep in mind when planning and carrying out the installation are:

- Mounting location restrictions for The WaterHeater™ by ITR, Space Heating Module (optional), and exhaust outlet (to reduce noise, vibration, heat loss, etc.)

- Length, routing, and sizing of fluid lines, fuel lines, air flow tubing, exhaust piping and wiring.
- Unrestricted intake required to draw in outside air for combustion.
- Ability to easily access and service the product, especially fuel, plumbing, and electrical systems.
- After installation, requirement to purge water and fuel lines and inspect/test entire system using the ITR-supplied Inspection Check Sheet.

1.5 Equipment, Tools and Skills

As the user and/or installer, you must be qualified and authorized to do the installation, which requires mechanical aptitude and electrical knowledge. Make sure you comply with existing RVIA or ABYC industry practices, using the highest and most recent standards and codes. Good workmanship is essential. Please refer back to *Section 1.2, Protect Your Warranty*.

You will need the following equipment and tools (not supplied) to install the heating system. This list does not include optional equipment and accessories:

- Standard tools normally available in a well-equipped shop.
- Appropriate fasteners for mounting the heater unit.
- Stainless steel 1-1/2" ID exhaust piping, maximum 12' with no bends (see *Section 3 – Installing the Exhaust System*, for details when bends are present).
- ITR muffler.
- 1/4" supply and return fuel line, approved rubber or copper.
- Heater hose (to connect Space Heating Module [optional] hose fittings to interior fans).
- Domestic water hose and/or tubing to connect The WaterHeater™ by ITR hose fittings to the domestic water system.

1.6 Testing and Inspection

After all components have been properly installed according to standard practices, RVIA or ABYC standards, and the recommendations of this Installation and Operating Manual, The WaterHeater™ by ITR should be test-operated for inspection purposes.

For your convenience, you can use the pullout *Inspection Check Sheet* in this Manual. The Inspection Check Sheet is divided into progressive sections, allowing each phase of the inspection to be carried out systematically, and then signed off by authorized persons.

Mounting - The WaterHeater™



2.1 Before You Begin

Plan the location of The WaterHeater™ by ITR and all its major components in advance to ensure the chosen locations are feasible and within the technical specifications.

Consider the following factors to help you decide exactly where best to mount The WaterHeater™ by ITR:

- The WaterHeater™ by ITR weight when full.
- Ventilation requirements.
- Exhaust outlet location and maximum acceptable length.
- Thru hull location.
- Potential for vibration and jarring.
- Fuel storage location.
- Most efficient plumbing runs.
- Safe and convenient access for maintenance.
- Number and location of interior fans.
- Location of other equipment to be installed or connected to The WaterHeater™ by ITR, including Space Heating Module, Zone Control Box, heat exchangers, overflow tank, batteries, etc.

! WARNING

Make sure you are familiar with *Section 1 – Overview* of this Manual. If the system is not installed according to specifications and with the correct equipment, The WaterHeater™ by ITR may not operate properly, safety may be compromised, and your Warranty may be voided.



2.2 Identifying The WaterHeater™ by ITR Model

As the owner, you must be fully aware of the controls and operating features particular to your model of The WaterHeater™ by ITR. This is essential for the proper functioning and life of The WaterHeater™ by ITR as well as protecting your warranty. Your model can be identified by locating the serial number label on the outside case of The WaterHeater™ by ITR. The serial number identifies the model type through the first series of letters and numbers.

The types of The WaterHeater™ by ITR models are:

HWH – The WaterHeater™ by ITR



2.3 Your Mounting Location

Your mounting location should consider the following:

- Mounting location must be able to support double the gross weight of The WaterHeater™ by ITR (i.e. 150 lbs. x 2 = 300 lbs/68 KG x 2 = 136 KG) and must be of a non-combustible surface.
- The WaterHeater™ by ITR is 14"H x 14"W x 24"D (35.6 cm x 35.6 cm x 60.9 cm). See *Figure 2-1: Dimensions*.

! CAUTION

The WaterHeater™ by ITR must not be installed in any compartment with flammable gases.

- The WaterHeater™ by ITR must be completely isolated from living spaces. Combustion air must be drawn from an outside source and cannot contain any combustible gases.
- The WaterHeater™ by ITR must be mounted in an area that provides unrestricted access to the front panel mounted fuel and water connections, and top mounted power and exhaust connection (minimum of 10" top clearance – top exhaust version; and, minimum of 6" top clearance – bottom exhaust version) and 3" clearance to all other WaterHeater™ surfaces.

- The WaterHeater™ by ITR must not be installed in any compartment with flammable gases.
- The WaterHeater™ by ITR must be mounted horizontal and level using eight (8) x 1/4" through bolts and 1" diameter fender washers, lock washers and nuts.
- It is recommended that a catchpan be placed under The WaterHeater™ by ITR for containing any unexpected leakage.

NOTICE

If The WaterHeater™ by ITR is going to be mounted in the engine compartment, check for adequate ventilation. When the engine is running, this area could be under a negative pressure. Make sure the air intake and exhaust hoses have no leaks and are well-fastened to the heater, muffler and thru hull fitting. Assembly parts that may cause injury through accidental contact should be protected.

Isolate the unit in a closed compartment so that no air from the heater will infiltrate the living areas.

- Choose a sturdy surface in a location that won't be unduly affected by vibration and the jarring of rough roads or rough seas.
- Mount the unit with the front panel side facing out and accessible. Facing out simplifies installation and maintenance.
- Open access is required to properly service the heater. Leave room at the **front**, and **top** of the unit.
- Ensure that the exhaust tubing can be properly and safely routed to the outside. The maximum exhaust run for the system is 12'.

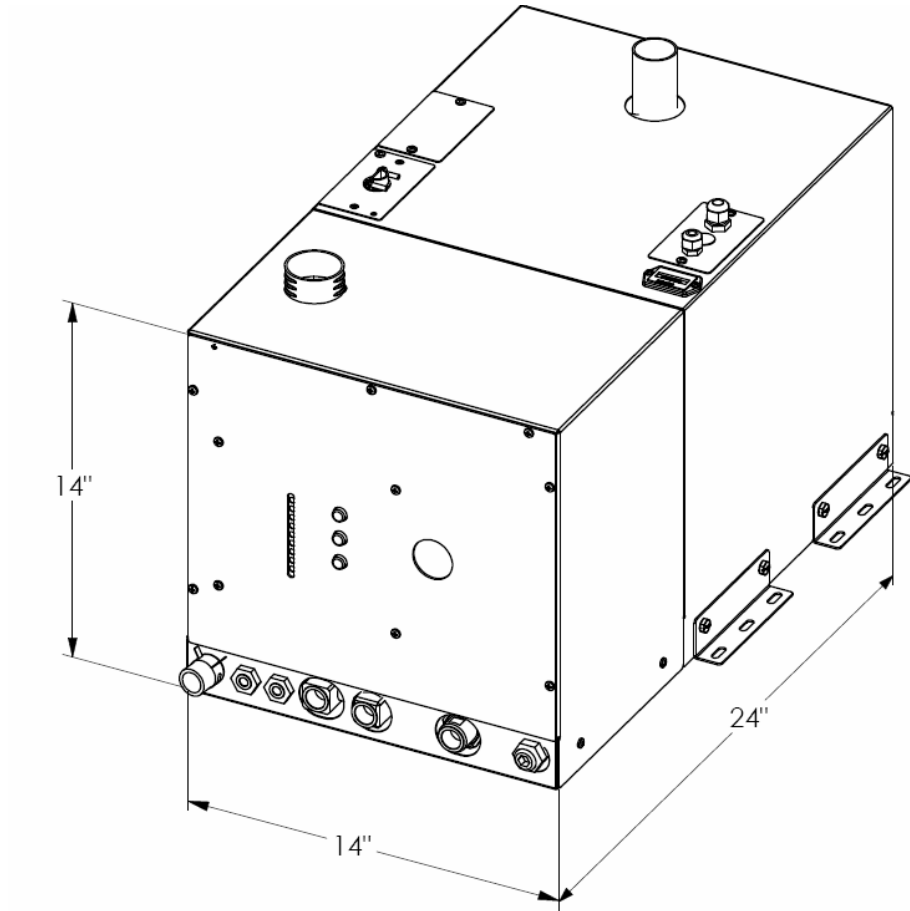

Figure 2-1: Dimensions



2.4 What NOT to Do

- **Don't** mount The WaterHeater™ by ITR in the rear of the coach or yacht underneath the sleeping area. The sound of The WaterHeater™ by ITR cycling on and off may disturb light sleepers.



2.5 Procedure

After choosing the mounting location for The WaterHeater™ by ITR:

- 1 Mount The WaterHeater™ by ITR horizontally and level.
- 2 Secure The WaterHeater™ by ITR in place (against the wall, floor, or a mounting platform) and eight (8) x 1/4" through bolts and 1" diameter fender washers, lock washers and nuts (See *Figure 2-2: Location of Mounting Brackets.*).

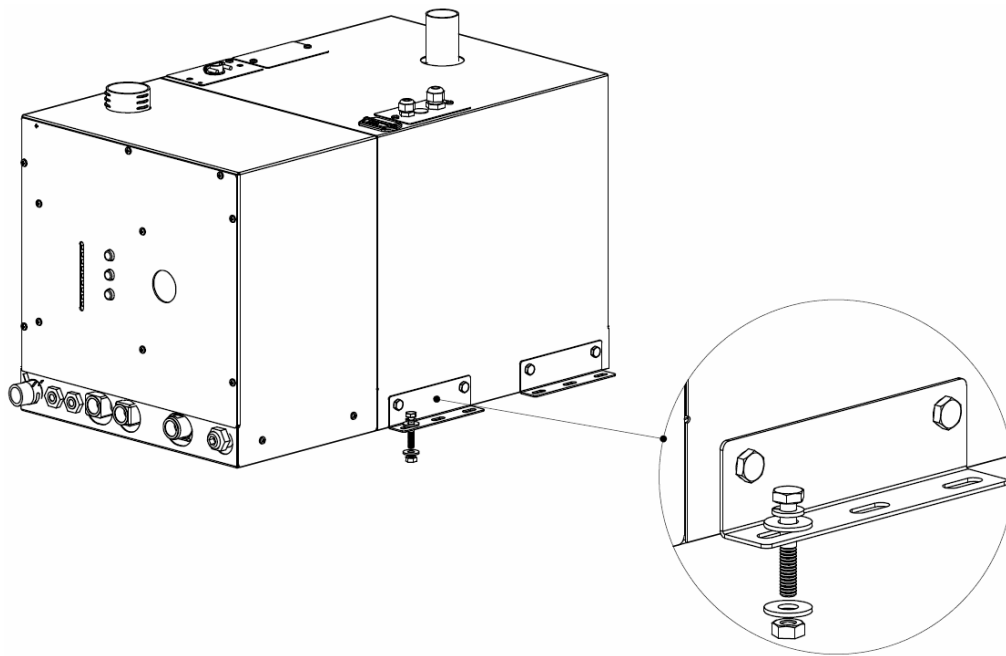

**Figure 2-2: Location of Mounting Brackets.
Insets: Bracket/Nut/Bolt Configurations**

Installing the Exhaust System



3.1 Before You Begin

For efficient and safe operation of The WaterHeater™ by ITR follow all recommendations for properly installing the exhaust. Any deviations from these must be approved in advance by ITR.

! DANGER

Although the heater's exhaust produces very low carbon monoxide emissions, caution is still advised:

- Do not operate The WaterHeater™ by ITR in an enclosed area unless there is adequate ventilation.
- Isolate The WaterHeater™ by ITR in a closed compartment so that no air from the unit will infiltrate the living areas.

Never place any exhaust parts close to combustible material or through a combustible wall or ceiling without fireproof protection. The exhaust can reach high temperatures.

3.2 Mounting Location

If you can't meet the technical specifications for mounting the exhaust, don't use The WaterHeater™ by ITR. The unit may perform poorly or become damaged if not installed according to specifications.



Recommended Exhaust Outlet Locations

The following is recommended for a coach exhaust outlet location:

- Mount the exhaust outlet **outside** the coach, not inside the heater compartment. Otherwise, exhaust fumes could infiltrate the coach from The WaterHeater™ by ITR compartment.

- In a coach, the typical mounting location for the exhaust outlet is under the floor of the heater compartment (see Figure 3-1), or on the other side of the coach, directly across from the heater unit. Keep in mind you cannot exceed 12' of exhaust piping, including bends.
- Position the outlet of the exhaust pipe so that the exhaust exits off the side of the coach, not towards the front, back, directly underneath the coach, or under an openable window, vent or slide-out.

In a yacht installation, the following is recommended for the exhaust outlet location:

- Make sure that the thru hull is at least 30" above the water line with a goose neck rise on the exhaust to help eliminate water from getting to The WaterHeater™ by ITR through the exhaust. If the dual exhaust air-intake thru hull is used, ensure that the air-intake is placed between 10 o'clock and 2 o'clock and also goose-necked to avoid water ingestion, see Figure 3-2.
- There needs to be a 1/8" air gap around the exhaust thru hull. The standard thru hull is 3" in diameter. The hole for the fitting should be 3-1/4". Make sure that the holes for the mounting screws have enough material left to properly bite. The fitting must be centered in the hole.



Recommendation for Installation

The following applies to both a coach and yacht:

- You may use sweep bends but each 90° bend is equivalent to one foot of exhaust piping. For example, if you use two 90° bends you must deduct one foot per bend from the maximum allowed 12' straight exhaust pipe length. Therefore you will be restricted to 10' of straight exhaust piping plus the two bends. Do not exceed these recommendations.
- Combustion air must be drawn from outside the coach or yacht.
- Use an ITR-manufactured muffler; no other muffler is acceptable.
- Exhaust outlet is on the top or bottom (model dependant) of The WaterHeater™ by ITR, towards the back.

! DANGER

The exhaust and outlet are **HOT** and the surrounding areas must be thermally shielded and protected from the hot surfaces and heat buildup by insulation. Nothing can come into inadvertent contact with any part of the exhaust system

- Exhaust pipe must have a minimum of 3" (7.6 cm) clearance from all surfaces.
- Ensure that the exhaust cannot be plugged or restricted.
- The exhaust fitting on The WaterHeater™ by ITR is 1.5" O.D. and the exhaust pipe used must have a minimum of 1.5" I.D throughout its length.
- All exhaust elbows must be of a large radius design (minimum radius 2.0").
- The exhaust must be supported a minimum of every 3' of its installed length.
- The exhaust and The WaterHeater™ by ITR connection point must use appropriate clamps and sealing compound to ensure that the connections are tight and leak free. The WaterHeater™ by ITR exhaust outlet pipe and the exhaust pipe itself must not be distorted or damaged during this process.
- When The WaterHeater™ by ITR is running, the connection points and the system must be checked for leaks and any found must be corrected. Periodically, check the exhaust fittings, connections, exhaust tube and insulation for leaks and integrity and correct if required.
- Appropriate exhaust insulation must be used to cover the entire length of any interior exhaust run.
- Solid stainless steel exhaust tubing is recommended but an approved stainless steel flexible exhaust tubing can be used. If flexible exhaust tubing is used the exhaust tubing must be inspected regularly for leaks and deterioration as this type of exhaust does not have the life expectancy of solid tubing. Stepped band clamps are recommended for joining flex and solid tubing as they apply firm, even pressure.
- In a coach, install an exhaust collar on the exhaust pipe to isolate the pipe from the coach.



What NOT to Do

Don't mount the exhaust pipe inside the heater compartment.

Don't use more than 10' of exhaust pipe including no more than 180° of total bends.

Don't use mufflers with any flow restrictions.

Don't over tighten exhaust clamps or you may crush The WaterHeater™ by ITR's exhaust spout.



3.3 Procedure

Figure 3-1 shows a standard setup for the down exhaust. To install the exhaust system:

- 1** Leave suitable air spacing to protect combustible materials; use an exhaust collar and metal shields where required.
- 2** Securely seal the exhaust piping to The WaterHeater™ by ITR fitting using an approved exhaust clamp.
- 3** Connect the exhaust piping in series with the muffler, using heavy-duty exhaust clamps. If you use vibration isolation mounts they must be high temperature.
- 4** Connect the air-intake tubing (2" I.D.) to the air-intake fitting on top of the heater, and to an outside air-intake fitting or dual thru hull (outside air only). Ensure the run of tubing is as short as possible to facilitate air flow.
- 5** Secure both ends of the air-intake tubing with properly sized hose clamps to prevent air leaks.
- 6** Make sure the air-intake and exhaust hoses have no leaks and are not touching each other.
- 7** On a yacht, make sure the thru hull is at least 30" above the waterline and the exhaust must be goose-necked (see Figure 3.2).

Section 3, Installing the Exhaust System

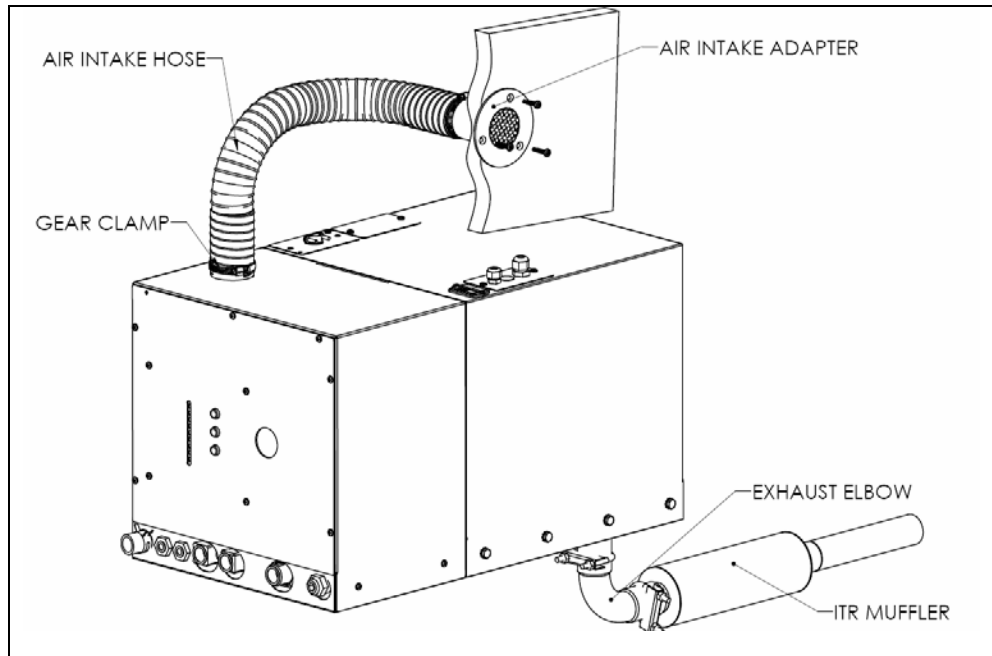

Figure 3-1: Installing the Exhaust System (Down Exhaust)

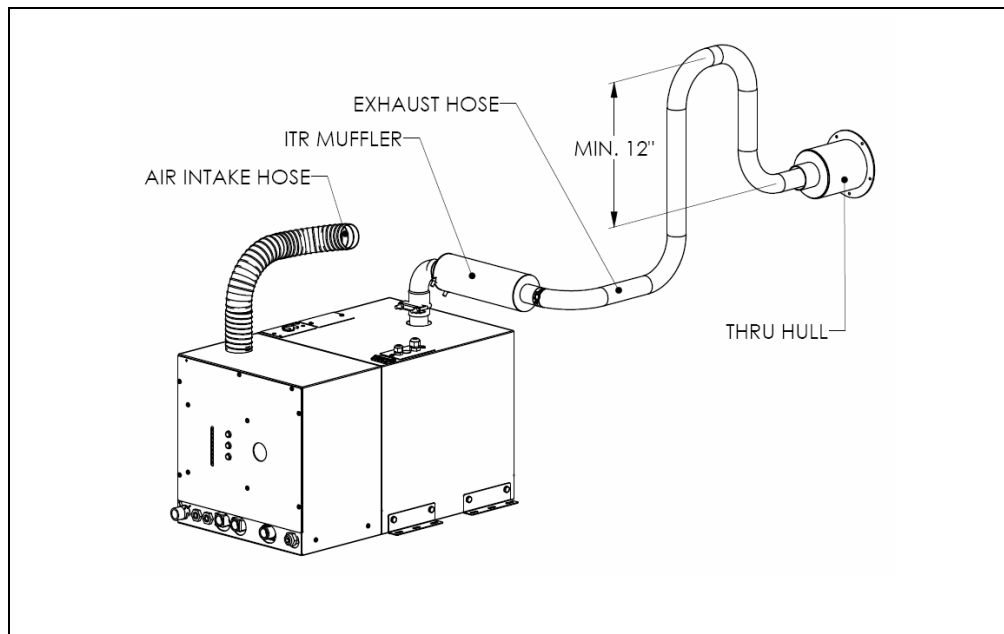
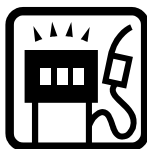

Figure 3-2: The Exhaust Goose Neck Configuration

Installing the Fuel System



4.1 Before You Begin

For efficient and safe operation of The WaterHeater™ by ITR, follow all recommendations for properly installing the fuel system. Any deviations from these recommendations must be approved in advance by ITR.

! DANGER

Never use gasoline in The WaterHeater™ by ITR. Use only diesel fuel, furnace oil, stove oil or kerosene.

Keep fuel lines away from any heat source above 100°F (38°C).

Keep gasoline and any equipment that uses gasoline away from The WaterHeater™ by ITR location. The WaterHeater™ by ITR is not rated for use in an explosive environment.

! WARNING

Never share the fuel supply to The WaterHeater™ by ITR with any other fuel-burning device.

4.2 Fuel System Installation



Recommendation for Installation

The WaterHeater™ by ITR's fuel connections are accessed from the front panel of the heater. The fuel inlet and fuel return are labelled and located on the front lower face of The WaterHeater™ by ITR and are not interchangeable. These fittings consist of 1/8" female NPT that connect to the fuel pump inside the units' front cover.

The following is recommended for the fuel system installation:

The fuel supply requires a dedicated pickup line from the main fuel tank. The pickup must allow the heater to run out of fuel before the tank itself is empty.

- The fuel supply from the fuel storage tank to the fuel inlet must be from a dedicated fuel pickup on the top of the tank.
- The fuel supply line should be installed with minimal rise from the fuel tank. In no event should The WaterHeater™ by ITR be more than 60" above the fuel tank.
- The fuel return line should be installed from The WaterHeater™ by ITR to the fuel tank.
- The fuel line must be run and secured so as to prevent damage, chafing and kinking during normal operation.
- All fuel line connection points and hoses must use suitable clamps and/or sealant and must be checked for leaks on the initial installation and also periodically as part of normal maintenance.
- A primary, UL and/or CSA approved fuel oil filter (not provided) must be installed inline in the fuel supply hose between the tank and The WaterHeater™ by ITR, in a manner that ensures easy access for maintenance. A secondary fuel filter is mounted inside The WaterHeater™ by ITR case. Both filters must be inspected and replaced as required as part of normal maintenance.
- Fuel line hose used must be appropriate for your requirements. It is strongly recommended that the hoses have permanently installed end fittings.



4.3 What NOT to Do

- **Don't** allow the fuel or the fuel lines to become contaminated with foreign material.
- **Don't** allow the fuel lines to become damaged or constricted.

! CAUTION

Ensure that fuel lines are always protected from contamination by foreign material. When installing or servicing, seal off ends to prevent contamination. After installing, you may also wish to flush the fuel line to rid of it air and any foreign material.

Be sure that all fuel lines are secured and will not become pinched, kinked or damaged during normal operation.



4.4 Procedure

To complete the fuel system installation:

- 1** Install the inline fuel filter. The optimal location is on a compartment wall next to The WaterHeater™ by ITR, inline between the fuel tank and The WaterHeater™ by ITR.
- 2** Connect the fuel line to the dedicated fitting on the main diesel fuel tank.
- 3** Inspect the supply and return fuel line for any loose connections or damage. Fittings must be airtight.
- 4** If desired, install a shut-off valve on the tank side of the fuel filter to allow shutdown and filter service.

Installing Fan Heaters – With “Space Heating Module” Only



5.1 Before You Begin

ITR makes a variety of fan heaters that can be independently controlled by a thermostat. There are cabin heaters and Spacesaver heaters (where space is limited). These heaters draw as little as 0.9 amps and deliver 140 cfm. These heaters also come in high output versions and the above numbers are increased by 40%. They should be mounted as close to the floor as possible. They have a built-in aquastat which turns on the fan when the water running through it reaches 120°F (49°C).

The Defrost Heater provides up to 28,000 BTU/h and uses a three speed fan, 200/275/450 cfm, 40/55/100 watts.

Note: A limited number of fan heaters can be used with The WaterHeater™ by ITR.

NOTICE

Only the installation of ITR fan heaters is covered in this Manual.

If you are installing non-ITR fan heaters, you must obtain prior approval from ITR. You must check the fans' total amperage draw to ensure they will be compatible with the Zone Control Board, as well as flow capacity to ensure that each fan meets system requirements.

5.2 Fan System Operation

ITR fans consist of a 12 VDC brushless fan and heater coil similar to a radiator.

When the heater unit comes on, the fan draws ambient air from the interior, blows it through the heater coil and back into the interior through a vent. There must be an input and output vent for each fan unit.

Features

- ITR heater fans are supplied with a built-in aquastat which prevents fan operation until the system has reached minimum operating temperature. The aquastat can be deleted to meet particular installation requirements, but it is recommended that all systems be installed with the air fan aquastat. *Figure 5-1* shows how to wire-up the aquastat in a fan.

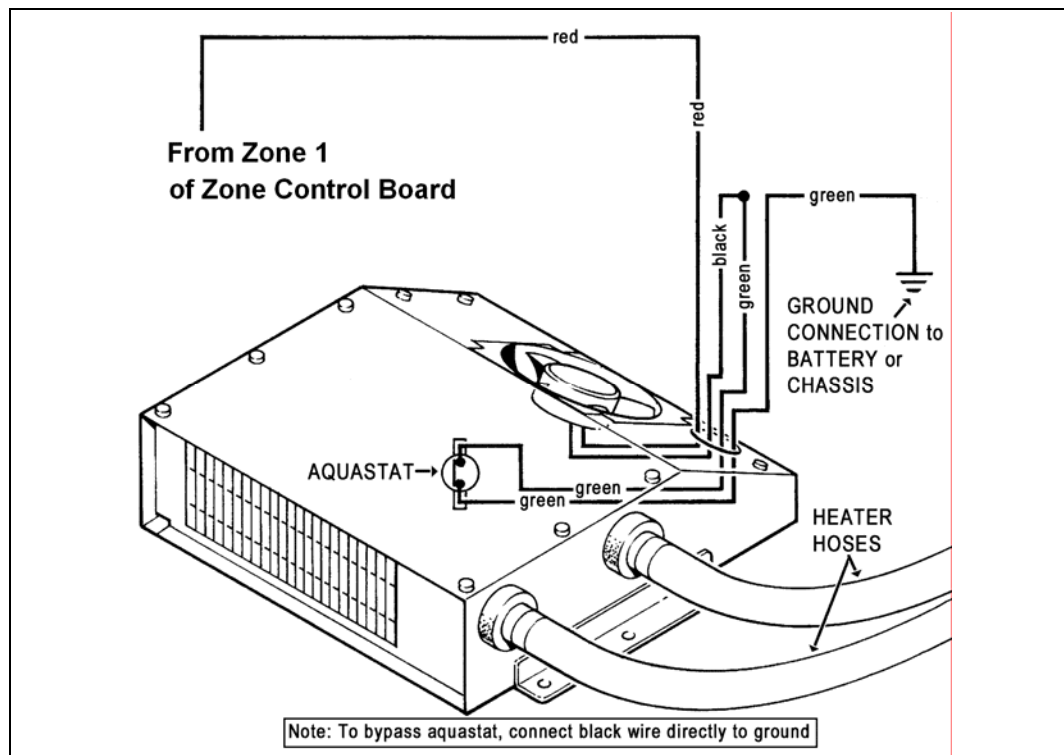

Figure 5-1: Wiring the Fan's Aquastat

- If a "passive" radiant heat system is desired (i.e. baseboard or fin and tube configurations), consult ITR for recommended installation procedures and design.

Single Zone Heating

The WaterHeater™ by ITR is capable of heating a single interior zone using the optional Space Heating Module. See *Section 9 – Installing the Space Heating Module*.

A single thermostat (positive DC compatible) can be installed to allow temperature regulation of the zone. The thermostat controls the fan heater.

For larger installations, consult ITR.

Accessories and Components Needed

In addition to the fans themselves, you will need at least some of the following optional accessories and equipment which are not supplied:

- **Thermostat** — a single thermostat can be installed in the interior.
- **Air Outlet Vents** — covers that are installed flush with the wall to vent heat for the installed heater unit.
- **Fan Guards** — to protect the fan blades from damage, recommended for fans installed in storage areas or other accessible areas where something could contact the fans.
- **Screws** — #10 sheet metal screws or wood screws to mount the fan units. See *Figure 5-2, Mounting a Spacesaver Fan*.
- **Two-Speed Fan Switches** – to enable low and high-speed settings from inside the coach or yacht; for use with the ITR cabin heater and Spacesaver fan.
- **Three-Speed Fan Switches** — to enable low, medium and high-speed settings from inside the coach or yacht; for use with the ITR defrost heater.
- **Air Ducting** — to allow you to install fans in a remote location (i.e. not directly adjacent to the interior space to be heated) and duct the heated air to its output location. Also, **air outlet plates** to allow you to install ducting for one, two or three separate outlets (e.g. you can use one fan to heat two different areas by installing a dual air outlet plate).



5.3 What NOT to Do

- **Don't** install more than two (2) fans, or fan(s) that require more heat than The WaterHeater™ by ITR can produce. Your heating system will not run effectively. (If you choose to use a higher-draw fan motor, install a relay to handle the extra load; see *Figure 5-3: Installing a Relay for Additional Fan Amperage*).
- **Don't** mount the return air outlet too close to the fan's air intake source.



5.4 Mounting Locations

Carefully choose the mounting locations of your fans:

- Locate the fan to evenly heat the zone.
- Provision must be made to protect water lines from freezing.
- Install fan at floor level or very near floor level, in order to optimize circulation.
- Allow a minimum 16 square inch (100 cm sq.) opening in the fan heaters' mounting compartment to allow sufficient intake of air.

ITR can suggest optimal fan locations if you provide a floor plan of your coach.

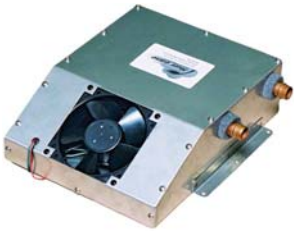

ITR's Spacesaver fan (pictured at left) has two stainless steel mounting brackets welded to the side of the case. It is designed to be mounted horizontally on a flat surface. This fan can also be ordered with a right-hand or left-hand hose configuration.

ITR's standard cabin heater fan comes with loose stainless steel brackets. The fan can be mounted on the floor or on the wall, either flat or on its side.

The thermostat should not be mounted on walls outside of the zone because that could cause false temperature readings. Mount on interior walls and bulkheads, away from windows and heater vents.



5.5 Procedure

After choosing the appropriate mounting location and configuration:

Section 5, Installing Fan Heaters

- 1 Mount the fan using #10 sheet metal screws or wood screws.
- 2 If you are using ducting and a dual air outlet plate for any fan, limit the total length of duct for both outlets to 36" for optimum air output.
- 3 Select the appropriate mounting location for the thermostat, as well as any fan speed switches. You will wire these up to the Zone Control Board, see *Section 9 - Installing the Space Heating Module (Optional)*.
- 4 If the fan(s) require(s) more than 8 amps, install a separate relay to power the fans. This relay will use the existing fan circuit as a signal and must be wired to a secondary power source (not the heater's Control Board). See *Figure 5-3: Installing a Relay for Additional Fan Amperage*.
- 5 To install plumbing lines to the fans, see *Section 7 - Plumbing the System*.

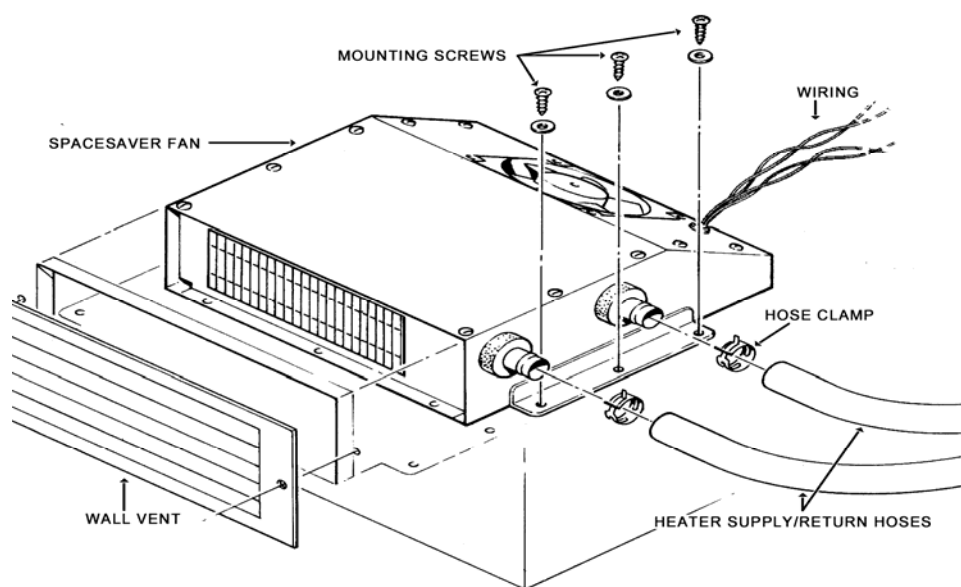

Figure 5-2: Mounting a Spacesaver Fan

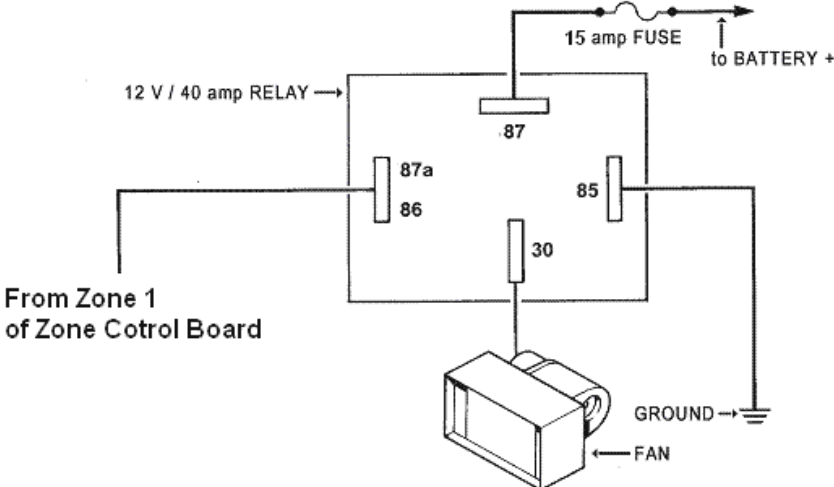

Figure 5-3: Installing a Relay for Additional Fan Amperage

Wiring the Electrical System



6.1 Before You Begin

The WaterHeater™ by ITR and its electrical Control Board are pre-wired and have been thoroughly tested together as a unit.

To review the wiring system for The WaterHeater™ by ITR, refer to the schematic in this *Section 6, Figure 6-1: System Wiring*.

! WARNING

All electrical connections and wiring must comply with normally-accepted 12 VDC and 120 VAC wiring practices, local regulations, and ABYC/RVIA standards. Only a qualified electrical installer should complete the wiring. All field wiring is to be in accordance with CSA Standard C22.1, Canadian Electrical Code Part I or the National Electric Code.

6.2 12 VDC

The following apply to the 12 VDC connections to the The WaterHeater™ by ITR:

- There is one paired set of 12 VDC electrical connections on the top right of The WaterHeater™ by ITR. They consist of the primary DC positive (red) and negative (black) connection and are 14 gauge stranded copper wires.

! WARNING

Primary DC power should originate from a dedicated connection on the house battery bank. A 20 amp fuse or breaker must be included inline from the battery to the positive (red) connection on The WaterHeater™ by ITR. The primary power wire gauge must be sized to permit no more than a 3% voltage drop from the battery to The WaterHeater™ by ITR.

- A properly-shielded power system is required for safe, trouble-free operation.

6.3 120 VAC

- The WaterHeater™ by ITR is equipped with one 1500 watt 120 VAC electrical element. The connections for the electrical supply are on the top left side of The WaterHeater™ by ITR, under a cover, labeled AC power.
- The power wires for the AC elements are three 14 gauge stranded copper leads that use standard AC color code (black - hot, white – neutral, green - ground). These are to be connected using standard 120 VAC electrical connectors and terminals. Once the connection is completed, the wires are to be inserted back into their compartment and the cover secured.

NOTICE

Do not operate the electric elements until water is added to The WaterHeater™ by ITR and Space Heating Module (optional) and all trapped air has been removed.

6.4 Remote Operating Panel Cable

- The other connection on the top right of The WaterHeater™ by ITR is a short four (4) wire remote operating panel cable with a four (4) pin connector. This connects to a matching 25' connector cord that plugs directly into the Remote Operating Panel. Refer to *Figure 6-1: System Wiring*.

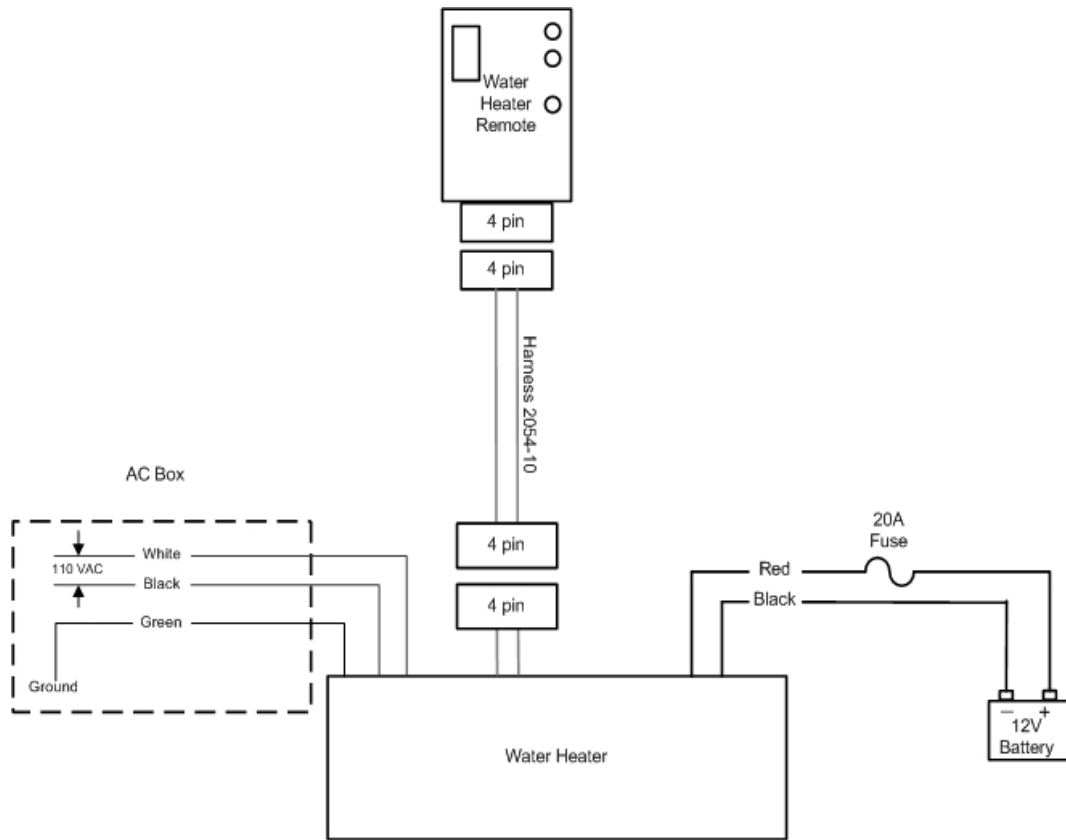

Figure 6-1: System Wiring

6.5 Main Electronic Control Board

- The main electronic Control Board is mounted on board The WaterHeater™ by ITR itself. It has no user adjustable components.

6.6 Space Heating Control Board (optional)

- The Space Heating Module (optional) is controlled by a separate Space Heating Control Board. See *Section 9 – Installing the Space Heating Module (Optional)*.



6.7 What NOT to Do

NOTICE

Never shut off The WaterHeater™ by ITR power via an inline battery or master switch while the system is running. Never disconnect the battery when The WaterHeater™ by ITR is running, and never disconnect the battery while the inverter is charging.

Doing either will severely damage The WaterHeater™ by ITR because it fails to automatically purge the combustion chamber. Such damage is detectable upon inspection and will *not* be covered under warranty. Always shut the system off using the normal system controls, after it has completed its purge.

Plumbing the System

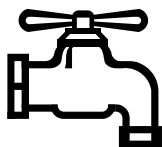

7.1 Before You Begin

For efficient and safe operation of The WaterHeater™ by ITR, follow all recommendations for properly installing the plumbing system. Any deviations from these must be approved in advance by ITR.

! DANGER

The WaterHeater™ by ITR if attached to the Space Heating Module (optional) must use the following:

Use only a non-toxic propylene glycol based coolant with additives generally recognized as safe "GRAS" by the FDA in the coolant side of the Space Heating Module.

For an efficient WaterHeater™ by ITR operation, you must:

- Minimize the heat loss from the hoses and eliminate air from the system.
- Follow the flow directions for the fluids in The WaterHeater™ by ITR. *Section 1 – Overview, Figure 1-1: Hot Water Heater and Space Heating Module, if installed, shows how the water flows through The WaterHeater™ by ITR and how the circulation fluid (propylene glycol antifreeze and water is recommended) flows in and out of the Space Heater Module . Section 9 – Installing the Space Heating Module , Figure 9-1: Space Heating Module Plumbing Fittings, shows a typical plumbing layout for circulating to the cabin fans.*

When heat is called for, the heating water pump in the Space Heating Module (optional) sends heated fluid out to the cabin fans.

7.2 Plumbing Installation

NOTICE

Do not operate The WaterHeater™ by ITR until water is in the WaterHeater™ and heating system, and all trapped air has been bled.

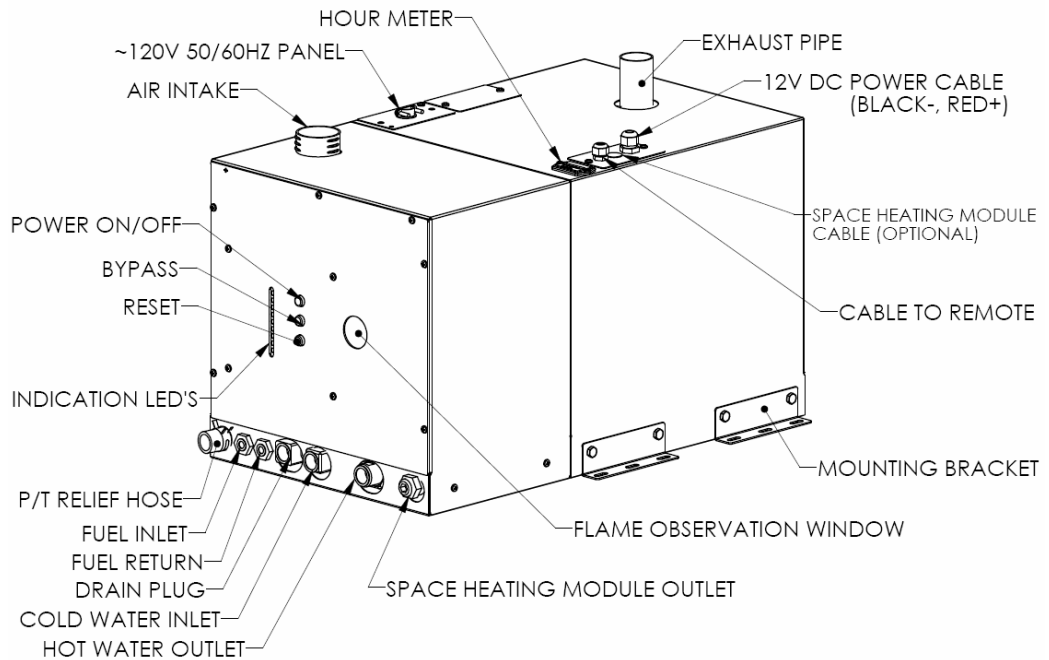

Figure 7-1: Plumbing Fittings

The plumbing installation should consider the following:

- All fittings on The WaterHeater™ by ITR require two wrenches when tightening. One wrench must be placed on the tank fitting and held in place to prevent this fitting from being overstressed. The other wrench can be used to tighten the matching half of the fitting onto it. Failure to follow this procedure will damage The WaterHeater™ by ITR and the fittings.
- For connecting the hot water heater to the Space Heating Module, if installed, see *Section 9 – Installing the Space Heating Module*.
- All fittings, hose and/or tubing involving the domestic water must be approved for use with domestic water and rated for the domestic water system pressure. The working pressure limit of The WaterHeater™ by ITR tank is 150 psi.

NOTICE

All fittings on the WaterHeater™ require two wrenches when tightening.

NOTICE

All fittings, hose and/or tubing involving the domestic water component of the distribution module (optional) must be approved for use with domestic water.

- All plumbing lines must be run and secured so as to prevent damage, chafing and kinking.
- The Space Heating Module contains a distribution pump and heat exchanger and is pre-wired and pre-plumbed for ease of installation.
- The WaterHeater™ by ITR should be filled and flushed prior to operation to remove any foreign debris.
- The WaterHeater™ by ITR is supplied with a temperature/pressure relief valve and drain fitting. This valve drains through the drain relief hose located at an opening on the left front lower face of The WaterHeater™ by ITR and is labeled "Temp/Pressure Relief Valve". Do not block or plug the valve or the hose. See the label attached onto the drain relief hose for the proper utilization and routing of this hose (see below).

NOTICE

The WaterHeater™ is supplied with a temperature and pressure relief valve and drain relief hose. This valve drains through the drain relief hose located at an opening on the left front lower face of the WaterHeater™ and is labeled "Temp/Pressure Relief Valve". Do not block or plug the valve or the hose. See the label attached onto the drain relief hose for the proper utilization and routing of this hose.

CAUTION! THIS IS A DISCHARGE LINE!

IT IS CONNECTED TO THE COMBINATION TYPE TEMPERATURE AND PRESSURE SAFETY RELIEF VALVE AT THE TANK. PROPER INSTALLATION IS REQUIRED.

Discharge line should terminate through plain (unthreaded) pipe with at least a 6" (152mm) air gap from a location where any discharge will be clearly visible. In no case may a discharge line be directly connected to a sewer line. No reducing coupling or other restriction shall be installed in the discharge line. The discharge line shall be installed to allow complete drainage of both the valve and the discharge line. Discharge line material must conform to local plumbing codes or ASME requirements. Excessive length over 30' (9.14m), use of more than four elbows, or reducing discharge line size will cause a restriction and reduce the discharge capacity of the valve. Temperature and pressure safety relief valve should be inspected at least once every three years and replaced, if necessary. See tag attached to the valve for additional instructions.

- **Heater hose** — PEX tubing. Slip-on foam insulation coverings may be used over the hose fittings to reduce heat loss. Secure all hose connections with spring clamps.
- **Air vents** — Air vents for the fluid circulation system are not supplied, but may be optionally installed to help bleed air from the system.



7.3 What NOT to Do

NOTICE

Don't use low-quality heater hose.

Don't let the hose come into contact with solvents, which may cause it to soften and swell. If there is any risk that solvents may contact the hose, insert it into PVC plastic tubing for protection.



7.4 Installation Procedure

To install and connect The WaterHeater™ by ITR and heater hose (see *Section 1 – Overview, Figure 1-1: Hot Water Heater and Space Heating Module, if installed, and Section 9 – Installing the Space Heating Module, Figure 9-1: Space Heating Module Plumbing Fittings*, for details):

- 1 The supply and return plumbing connections are on the front lower face of The WaterHeater™ by ITR and are 1/2" female NPT fittings. The supply input is labeled "Cold Water Inlet" and the hot water output is labeled "Hot Water Outlet". Ensure proper direction of flow.
- 2 Two male 1/2" NPT PEX tube fittings (not supplied) must be fit into the supply and return fittings and tightened to a leak free condition.
- 3 Connect the domestic water holding tank to the Cold Water Inlet. In some installations, a check valve may have to be obtained and installed on the cold input line to The WaterHeater™ by ITR to prevent warm water from backfilling to the water storage tank. Check the appropriate standards and regulations. Ensure there are no kinks or sharp bends that might restrict the fluid flow. If bends are required for PEX tubing, fit the tubing into a plastic bend support. Do not use rubber heater hose for potable water plumbing. See *Figure 7-2: The Approved Method of Installing Heater Hose (Consult ITR for Alternative Methods and Products)* for methods of attaching heater hose.

- 4 Connect the hot water supply line to the Hot Water Outlet. Ensure there are no kinks or sharp bends that might restrict the fluid flow. If bends are required for PEX tubing, fit the tubing into a plastic bend support. Do not use rubber heater hose for potable water plumbing. See *Figure 7-2: The Approved Method of Installing Heater Hose (Consult ITR for Alternative Methods and Products)* for methods of attaching heater hose.
- 5 A drain point, labeled "Drain" is provided on the front lower middle face of The WaterHeater™ by ITR and consists of a 1/2" threaded pipe with a temporary plastic cap installed. Prior to filling The WaterHeater™ by ITR with water, remove the plastic cap and install the drain valve (provided) and tighten to a leak free condition. Use two wrenches. Use a food safe Teflon tape for thread sealant. If the Space Heating Module has been added, see the Space Heating Module instructions before installing the drain valve.
- 6 A suggested procedure for filling The WaterHeater™ by ITR is to close The WaterHeater™ by ITR drain valve, open the highest hot water faucet in the domestic water system, open the valve to the cold water inlet to The WaterHeater™ by ITR and then allow to fill. Once the water is flowing in a steady stream from the hot water faucet, close the faucet.

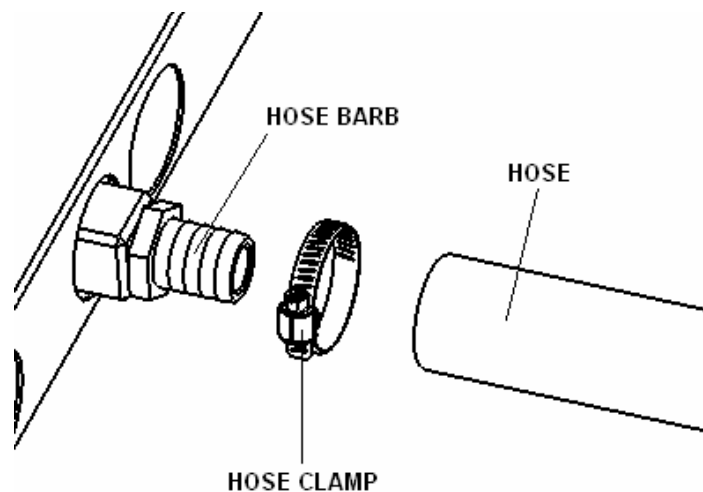

Figure 7-2: The Approved Method of Installing Heater Hose (Consult ITR for Alternative Methods and Products)

Operating The WaterHeater™

8.1 Operating Instructions for The WaterHeater™ by ITR

This section describes the operation and maintenance of your new WaterHeater™ by ITR.

The WaterHeater™ by ITR has the ability to support zone heating with the available add-on space heating module and Zone Control Board.

The WaterHeater™ by ITR must be installed and connections made in accordance with the recommendations in the Installation and Operating Manual prior to operating The WaterHeater™ by ITR.

NOTICE

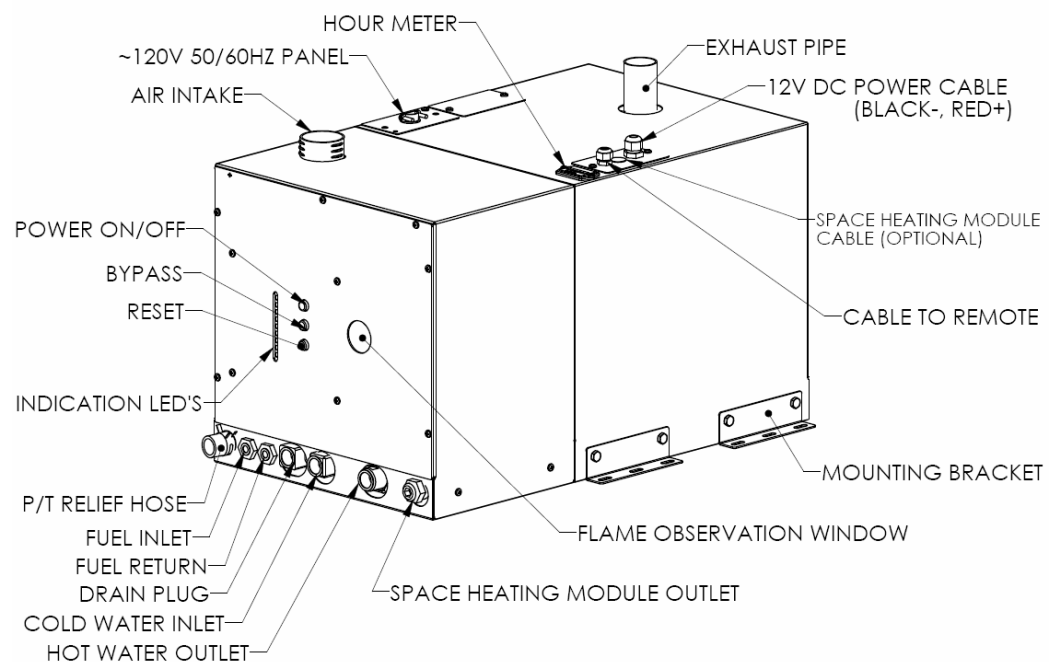

Figure 8-1: The WaterHeater™ by ITR - Fittings

8.2 Turning the Power to The WaterHeater™ by ITR “ON”

- The WaterHeater™ by ITR's Control Panel located on the WaterHeater™ itself contains three push buttons: ON/OFF power, Bypass and Reset. The power switch must be pushed ON (power LED will turn ON) to turn the DC electrical power to the main Control Board and WaterHeater™ ON and is required to be left ON during any period where heat is requested. When The WaterHeater™ by ITR is shut down for any extended period or the season it is recommended that the power switch be turned OFF.

8.3 Activating the Burner (Primary)

Activating the Burner (Primary Heat Source)

- The burner switch on the Remote Operating Panel controls the ON/OFF of the diesel burner (primary heat source). When the burner switch is turned ON, the diesel portion of The WaterHeater™ by ITR will turn on after ten seconds. The Burner LED on the Remote Operating Panel will turn ON when the diesel burner has been activated. The burner will continue to operate until the water in The WaterHeater™ by ITR reaches the set operating temperature range. At this point, the diesel burner will turn OFF. If The WaterHeater™ by ITR water should cool to outside of this temperature range, the burner will again come on and will continue until either the burner switch on the Remote Operating Panel is turned OFF or the temperature range is again achieved. If the burner switch on the Remote Operating Panel is turned OFF, the burner stops and The WaterHeater™ by ITR enters a two minute cool down stage prior to completely shutting down.

Activating the AC immersion element (Secondary Heat Source)

- Turn the AC breaker panel circuit breaker to the AC element ON. The AC Heat (green) LED on the remote operating panel will turn ON indicating the AC element is energized and the water is being electrically heated. It will continue to operate until the water in the WaterHeater reaches the set operating temperature range. At this point, the element will turn OFF. If the water should cool to outside of this temperature range, the AC immersion element will again be energized and will continue until either the AC circuit breaker is placed OFF or the temperature range is again achieved.

NOTICE

Do not operate the WaterHeater™ until it is filled with water and all trapped air has been bled.

Use only a non toxic propylene glycol based coolant with additives generally recognized as safe "GRAS" by the FDA in the coolant side of the Space Heating Module

Activating the Burner and AC Immersion Element Jointly

- Turn the burner switch on the Remote Operating Panel to the ON position. Place the AC circuit breaker to the element ON. The Burner and AC Heat (green) LED's on the Remote Operating Panel will turn ON indicating the diesel burner and AC immersion element have been selected.

8.4 Activating the Cabin Fan Heaters through the Thermostats

(Space Heating Module equipped model only) (Burner or AC Heat on)

- Any thermostat connected to the Space Heating Module and calling for heat will cause the cabin fan controlled by that thermostat to commence running. The ITR cabin fan heater has a built-in aquastat that prevents the cabin fan from starting until the coolant in the cabin fan heater itself has reached a set temperature. Once the room temperature has reached the temperature called for by the thermostat, the cabin fan will turn OFF.

8.5 Functions of the Remote Operating Panel

- The WaterHeater™ by ITR's Remote Operating Panel, *Figure 8-2: Remote Operating Panel*, contains one ON/OFF burner switch and three LED's indicating Burner activation, AC element activation, and service.

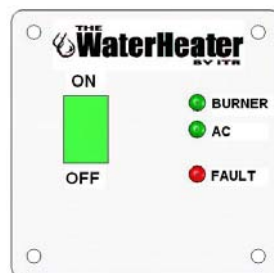

Figure 8-2: Remote Operating Panel

Burner Switch (Primary Heat Source)

- The burner switch controls the ON/OFF of the diesel burner. The Burner LED will turn ON when the diesel burner has been activated.

Burner LED (Green)

- When ON, indicates the diesel burner has been activated.

AC Heat LED (Green)

- When ON, indicates the 120 VAC immersion element has been activated.

Service LED (Red)

- When ON, indicates The WaterHeater™ by ITR has faulted. The specific fault can be identified by examining the WaterHeater™ Control Panel located on the WaterHeater™. There are three red and six green indicator LED's on this panel. Refer to the description of the WaterHeater™ Control Panel for further details.

8.6 Functions of The WaterHeater™ by ITR Control Panel

The WaterHeater™ by ITR's Control Panel, *Figure 8-3: WaterHeater™ Control Panel*, contains three push buttons: ON/OFF power, Bypass and Reset. In addition, it contains nine LED's indicating Power, AC Heat, Air Compressor, Fuel Pump, Combustion Fan, Igniter, Flame Fault, Voltage Fault and Low Water Level Fault.

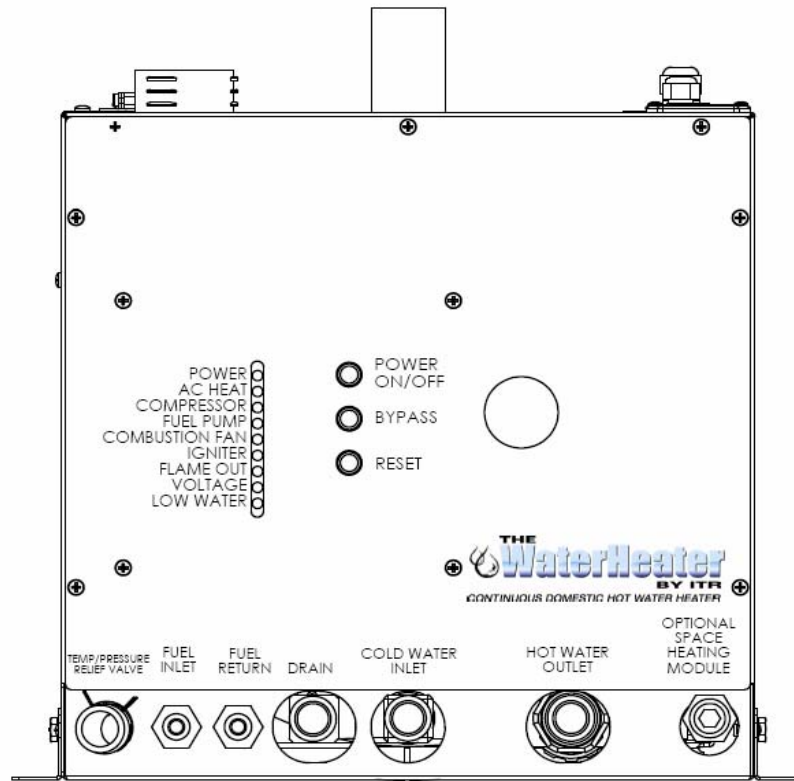

Figure 8-3: The WaterHeater™ by ITR - Control Panel

Power On/off Button

- The *Power On/Off* button turns ON/OFF the power to the WaterHeater™ Control Board. The Power LED (green) turns ON when the power to the control board is ON.

Bypass Button

- The *Bypass* button is for authorized service personnel only.

Reset Button

- The *Reset* button when pressed resets the WaterHeater™ Control Board.

Power LED (Green)

- The *Power* LED (green) turns ON when the power to The WaterHeater™ by ITR Control Board is ON. The LED flashes when the WaterHeater™ is in bypass mode.

AC Heat LED (Green)

- The *AC Heat* LED (green) turns ON when the AC immersion element has been activated.

Compressor, Fuel Pump, Combustion Fan, Igniter LED (Green)

- The air *Compressor, Fuel Pump, Combustion Fan* and *Igniter* LED's (green) turn ON when the component is ON, and will flash if the component is electrically open or shorted.

Flame Out LED (Red)

- The *Flame Out* fault LED (red) turns ON when a flame fault has been detected.

Voltage LED (Red)

- The *Voltage* fault LED (red) turns ON when a voltage fault has been detected.

Low Water LED (Red)

- The *Low Water* level fault LED (red) turns ON when a low water level in the WaterHeater™ has been detected.

8.7 Functions of the Space Heating Module (Optional) Zone Control Board

The Space Heating Module (optional) Zone Control Board contains six green LED's for power, heat available, thermostat, cabin fan, cabin fan pump, and WaterHeater pump.

Power LED (Green)

- The *Power* LED turns ON when the power to the Space Heating Module (optional) Zone Control Board is ON.

Heat Available LED (Green)

- The *Heat Available* LED turns ON when there is enough hot water heat for the cabin fan heaters to function without blowing cold air.

Thermostat LED (Green)

- The *Thermostat* LED turns ON when the thermostat in the space heating zone is calling for heat.

Domestic Water Pump, Cabin Fan Pump, Cabin Fan (Green)

- The Domestic Water Pump, Cabin Fan Pump and Cabin Fan LED's turn ON when the devices are functioning. They will be off if a fuse has been blown.

8.8 Maintenance

Customer Monthly Maintenance: Check the following and correct as required:

- Water and coolant (Space Heating Module) hoses and fittings for leaks and integrity.
- Check coolant level in the overflow bottle (for Space Heating Module); (3/4 full when hot). **Fill only when the module is COLD.**
- Exhaust fittings, connections, tubes for leaks, and integrity.
- Exhaust and air-intake checked for no obstructions.
- Fuel lines, fittings for leaks and integrity.
- External fuel filter for clogging.

Annual Factory Maintenance: Perform the following:

- **Factory Service Tune-up** (AC and DC power is disconnected):
- **Prior to operation for the season, a factory service tune-up of the modular system should be performed by trained service personnel.** Only personnel familiar with the equipment modules should perform the service tune-up. It is recommended that the dealer be contacted for this service or if not available, contact ITR for further instructions.
- As a general guide, the regular maintenance items such as the igniter, fuel nozzle, fuel filters (internal and external) and air filter (internal) should be replaced as opposed to inspected and cleaned. Their performance may be deteriorating and/or their remaining service life ending without any apparent visual signs or operating symptoms.

- The major components such as the air compressor, fuel pump, and combustion air fan should be examined for wear and should be replaced by the service technician as required. They are not serviceable and must be replaced.
- The combustion tube should be inspected by the service technician for wear and replaced if necessary. If the tube is satisfactory, a thorough cleaning of the tube and burner chamber should be performed.
- The domestic water mixing valve on the WaterHeater™ should be inspected every year and replaced if necessary. See the tag attached to the valve for additional instructions (see below).

This ____ Mixing Valve must be installed and adjusted per the supplied instruction sheet. It must be installed in accordance with applicable plumbing codes. To insure that the valve keeps working properly, periodically turn the handwheel a full number lower (higher) than the set number. If you do not detect a noticeable decrease (increase) in the discharge temperature, service the valve immediately. Otherwise, turn the handwheel back to the original setting.

This ____ valve was installed _____. The handwheel was set to number : _____. Any change in the setting to a higher number may raise the discharge temperature to an unsafe temperature which may lead to scalds.

- The temperature and pressure safety relief valve on the WaterHeater™ should be inspected every year and replaced if necessary. See the tag attached to the valve for additional instructions (see below).

DO NOT REMOVE THIS TAG FROM VALVE.

WARNING:

FAILURE TO COMPLY WITH THESE INSTURCTIONS REGARDING THIS VALVE CAN RESULT IN SERIOUS PERSONAL INJURY OR DEATH AND/OR SEVERE PROPERTY DAMAGE.

ANNUAL OPERATION OF T & P RELIEF VALVES

WARNING: Following installation, the valve lever MUST be operated AT LEAST ONCE A YEAR by the water heater owner to ensure that waterways are clear. Certain naturally occurring mineral deposits may adhere to the valve, blocking waterways, rendering it inoperative. When the lever is operated, hot water will discharge if the waterways are clear. PRECAUTIONS MUST BE TAKEN TO AVOID PERSONAL INJURY FROM CONTACT WITH HOT WATER AND TO AVOID PROPERTY DAMAGE. **BEFORE** operating lever, check to see that a discharge line is connected to this valve, directing the flow of hot water from the valve to a proper place of disposal. If no water flows when the lever is operated, replacement of the valve is required. **TURN THE WATER HEATER "OFF"** (see instruction manual) **AND CALL A PLUMBER IMMEDIATELY.**

REINSPECTION OF T & P RELIEF VALVES:

WARNING: Temperature and Pressure Relief Valves should be inspected AT LEAST ONCE EVERY THREE YEARS, and replaced, if necessary, by a licensed plumbing contractor or qualified service technician, to ensure that the product has not been affected by corrosive water conditions and to ensure that the valve and discharge line have not been altered or tampered with illegally. Certain naturally occurring conditions may corrode the valve or its components over time, rendering the valve inoperative. Such conditions can only be detected if the valve and its components are physically removed and inspected. **Do not attempt to conduct an inspection on your own.** Contact your plumbing contractor for a reinspection to assure continuing safety.

WARNING: FAILURE TO REINSPECT THIS VALVE AS DIRECTED COULD RESULT IN UNSAFE TEMPERATURE OR PRESSURE BUILD-UP WHICH CAN RESULT IN SERIOUS INJURY OR DEATH AND/OR SEVERE PROPERTY DAMAGE.

If discharge occurs, **CALL A PLUMBER IMMEDIATELY.** Discharge may indicate that an unsafe temperature or pressure condition exists which requires immediate attention by a qualified service technician or licensed plumbing contractor.

SEE WATER HEATER INSTRUCTION MANUAL FOR ADDITIONAL INFORMATION REGARDING THE TEMPERATURE AND PRESSURE RELIEF VALVE.

See other side for important information

WARNING: To avoid water damage and/or scalding due to valve operation, a discharge line must be connected to valve outlet and run to a safe place of disposal. The discharge line shall be installed to allow complete drainage of both the valve and the discharge line. No reducing coupling or other restriction shall be installed in the discharge line. The discharge line must pitch downward from the valve and terminate with a 6" (152mm) air gap from an approved location or building drain. The discharge line must terminate through plain (unthreaded) pipe. Discharge line material must conform to local plumbing code or A.S.M.E. requirements. Excessive length – more than 30 feet (9.14m), use of more than four elbows or bends in discharge piping, or reduction of discharge line size will cause a restriction and reduce the discharge capacity of the valve. No shut-off valve should be installed between the relief valve and tank, or in the discharge line.

To ensure proper operation, this valve must be installed by a qualified service technician or licensed plumbing contractor in accordance with these instructions and local plumbing codes and standards.

WARNING:

FAILURE TO COMPLY WITH THESE INSTRUCTINS REGARDING THIS VALVE CAN RESULT IN SERIOUS PERSONAL INJURY OR DEATH AND/OR SEVER PROPERTY DAMAGE.

Combination temperature and pressure relief valves with extension thermostats must be installed so that the temperature-sensing element is immersed in the water in the top 6" (152mm) of the water storage tank. They must be installed either in the hot outlet service line or directly in a tank tapping. Valves must be located so as to assure isolation from flue gas heat or other ambient conditions that are not indicative of stored water temperature. See other instructions regarding the discharge line.

This device is designed for emergency safety relief and must not be used as an operating control.

Repair or alteration of valve in any way is prohibited by national safety standards/local codes.

- Regular inspection and maintenance are a necessary part of a properly operating module and satisfactory performance.

8.9 Protect the WaterHeater™ and Space Heating Module (If Installed)

- Protect The WaterHeater™ by ITR and Space Heating Module from temperature extremes and any dusty, dirty, corrosive environment.
- Protect The WaterHeater™ by ITR and Space Heating Module from cold temperatures and corrosion. Protect the Space Heating Module coolant side by using a proper mixture of anti-freeze and water. Use only a non-toxic propylene glycol based coolant with additives generally recognized as safe “GRAS” by the FDA in the coolant side of the Space Heating Module. Read and follow the anti-freeze manufacturer’s instructions for the type of anti-freeze and mixture recommended for your application.
- Note that any domestic water in The WaterHeater™ by ITR or Space Heating Module will freeze in cold temperatures and will damage the components. The WaterHeater™ by ITR and Space Heating Module and all associated components must be completely drained of the domestic water and emptied before freezing temperatures are encountered.

8.10 General Troubleshooting

Insure that The WaterHeater™ by ITR has both sufficient battery voltage and water level as The WaterHeater™ is designed not to allow operation if either are incorrect (indicated by lit Voltage Fault or Low Water Level Fault LED's on The WaterHeater™ Control Panel) .

Burner Does Not Start Up

- WaterHeater™ connected to 12 VDC power?
- *Power On/Off* button on WaterHeater™ Control Panel pushed ON? *Power* LED lit on Remote Operating Panel?
- Burner switch on Remote Operating Panel ON?
- Fuses or circuit breakers blown or tripped?

AC Immersion Element Does Not Activate

- WaterHeater™ connected to 120VAC power?
- Circuit breaker tripped?

Burner Starts but Flame Faults

- Fuel supply present and adequate?
- Air-intake or exhaust not blocked or obstructed?
- Air in fuel line (White smoke from exhaust)?
- Fuel filter (external) dirty?
- Component LED's all glowing green on The WaterHeater™ Control Panel?

Burner Starts but Zone Faults

- Power LED on Space Heating Module Zone Control Board glowing green?
- Component matched LED pairings all glowing green on the Space Heating Module Zone Control Board?

Installing the Optional Space Heating Module



9.1 Before You Begin

If you decide to install a Space Heating Module, plan the location of the Space Heating Module and all its major components in advance to ensure the chosen locations are feasible and within the technical specifications.



Consider the following factors to help you decide exactly where best to mount the Space Heating Module :

- Space Heating Module weight when full.
- Potential for vibration and jarring.
- Most efficient plumbing runs.
- Safe and convenient access for maintenance.
- Number and location of interior fans.
- Location of other equipment to be installed or connected to the Space Heating Module, including Zone Box, cabin fan heaters, etc.

! WARNING

Make sure you are familiar with the *Section 1, Overview* of this Manual. If the system is not installed according to specifications and with the correct equipment, your Space Heating Module may not operate properly, safety may be compromised, and your warranty may be voided.



9.2 Identifying Your Space Heating Module Model

As the owner, you must be fully aware of the controls and operating features particular to your model of the Space Heating Module. This is essential for the proper functioning and life of your Space Heating Module as well as protecting your warranty. Your model can be identified by locating the serial number label on the outside case of the Space Heating Module. The serial number identifies the model type through the first series of letters and numbers.

The type of Space Heating Module model is:

SHM – Space Heating Module



9.3 Your Mounting Location

Your mounting location should consider the following:

- Mounting location must be able to support 50 pounds (23 KG).
- The module must be mounted in an area that provides unrestricted access to the front panel water and coolant connections (minimum of 6" top clearance for the side expansion tank) with 3" clearance to all other module surfaces.
- Module is 11"H x 12"W x 6.5" D (27.9 cm x 30.5 cm x 16.5 cm).
- Module must be mounted vertically and level using four, 1/4" through bolts using 1" diameter fender washers, lock washers and nuts.

! CAUTION

Space Heating Module must not be installed in any compartment with flammable gases.

- Space Heating Module must be mounted in an area that provides unrestricted access to the front panel mounted coolant

and water connections and 3" clearance to all other Space Heating Module surfaces.

- If the Space Heating Module is not mounted in the highest point of the circulating system, an inline bleeder must be added at the highest point of the system to allow removal of any entrapped air.

9.4 Selecting the Space Heating Module Zone Box Location

- Mount the Space Heating Module Zone Box (containing the zone board) vertically, close to the Space Heating Module. Allow sufficient room to access the internal fuses as well as to view the display LED's on the board itself.
- The module is connected to the space heating zone board through the electrical connections located at the bottom of the control board box and the distance apart is dictated by the length of the 2 and 4 pin connector cords used.

9.5 Plumbing Installation

! CAUTION

All fittings on the Space Heating Module and WaterHeater™ require two wrenches when tightening. One wrench must be placed on the tank fitting and held in place to prevent this fitting from being overstressed. The other wrench can be used to tighten the matching half of the fitting onto it. Failure to follow this procedure will damage the Space Heating Module, WaterHeater™ and the fittings, see *Figure 9-1: Space Heating Module Plumbing Fittings*.

Section 9, Mounting the Space Heating Module (optional)



Figure 9-1 Space Heating Module Plumbing Fittings

When installing the Space Heating Module, see *Figure 9-2: Space Heating Module and Hot Water Heater Hookup*, the following instructions apply to the WaterHeater™ and the Space Heating Module:

- Install the cold water inlet tee (supplied) into the fitting labeled cold water inlet located on the lower middle face of the WaterHeater™ and tighten to a leak free condition. If the drain valve has been previously installed on the WaterHeater™, the domestic water pump must be disabled and the WaterHeater™ tank drained before the valve is removed and the cold water inlet tee installed. Use two wrenches. Reinstall the drain valve into the axial side of the newly installed tee and tighten to a leakfree condition. Use a food safe Teflon tape on the fittings.
- Remove the plastic plug on the WaterHeater™ front panel labeled "Space Heating Module". The hot water supply from the WaterHeater™ to the Space Heating Module is a female 1/2" NPT fitting located behind the plug. This is to be connected to the Hot Water In connection on the Space Heating Module. Two male 1/2" NPT x 3/4" hose barbs (not supplied), 3/4" I.D. heavy duty rubber hose, and good quality hose clamps are recommended for connecting the two fittings together.

Section 9, The Space Heating Module (optional)

- The Hot Water Return connection from the Space Heating Module to the WaterHeater™ is on the front upper right face of the module and is a 1/2" NPT female fitting. This connects to the 1/2" NPT female fitting on the cold water inlet tee previously installed on the WaterHeater™. Two male 1/2" NPT x 3/4" hose barbs (not supplied), 3/4" I.D. heavy duty rubber hose, and good quality hose clamps are recommended for connecting the two fittings together.
- The space heating supply connection from the Space Heating Module to the cabin fan heater is labeled "Space Heat Out" and is a female 1/2" NPT fitting located on the upper left face of the module. A male 1/2" NPT x 3/4" hose barb (not supplied), 3/4" I.D. heavy duty rubber hose, and good quality hose clamps are recommended for connecting the module to the cabin fan heater.
- The space heating return connection from the cabin fan heater to the Space Heating Module is a female 1/2" NPT fitting connected initially to the bottom fitting on the attached expansion tank. Heavy duty, 3/4" I.D. rubber hose and good quality hose clamps are recommended for connecting the output of the cabin fan heater back to the top fitting of the expansion tank.
- A good quality overflow tank is recommended to be connected to the expansion tank on the Space Heating Module.

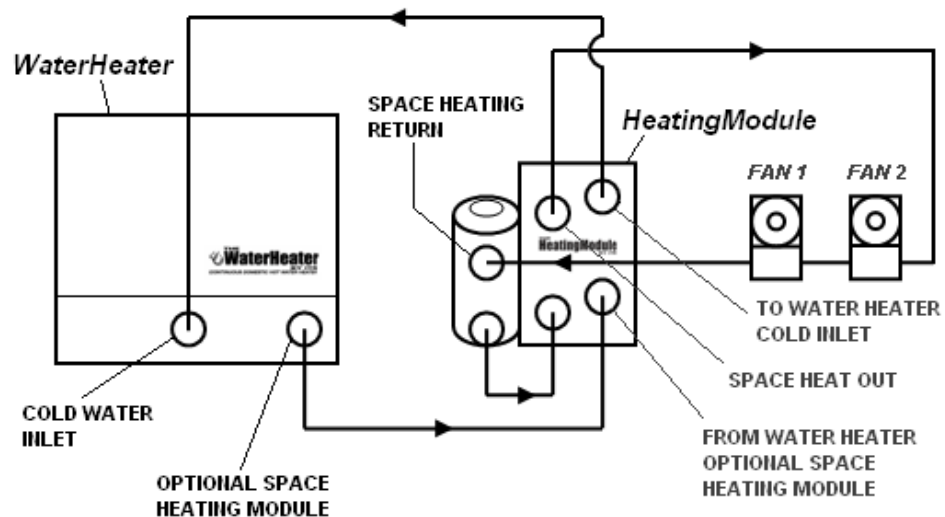

Figure 9-2: Space Heating Module and Hot Water Heater Hookup

! CAUTION

Do not operate the Space Heating Module and WaterHeater™ until water is in the domestic water side of the Space Heating Module and all trapped air has been bled.

Do not operate the Space Heating Module and WaterHeater™ until coolant is in the coolant side of the Space Heating Module and all trapped air has been bled.

The Space Heating Module should be filled and flushed prior to operation to remove any foreign debris.

! DANGER

Use only a non-toxic propylene glycol based coolant with additives generally recognized as safe "GRAS" by the FDA in the coolant side of the Space Heating Module.

9.6 Electrical Connection

! CAUTION

All field wiring is to be in accordance with CSA Standard C22.1, Canadian Electrical Code Part I, the National Electric Code, or local regulations.

12 VDC

- Primary DC power to the Space Heating Module should originate on either a battery direct circuit or after the master disconnect switch from a dedicated connection on the house battery bank.
- The power connection to the module from the power supply is through the Space Heating Zone Board itself. A 15 amp fuse or breaker must be included inline from the power source to the positive connection on the space heating zone board. The primary power wire gauge must be sized to permit no more than a 3% voltage drop from the power supply to the zone board. There are no direct 12 VDC power connections onto the Space Heating Module itself.

9.7 Space Heating Zone Board

2 Pin Connector cable and clip on aquastat

- The Zone Board has a 2 pin connector cable, see *Figure 9-3: Space Heating Module and Zone Board Electrical Hookup*, that is to be connected through a connector cord (supplied) to the connector on the leads on the clip on aquastat (previously installed on the WaterHeater™).

4 Pin Connector Cable

- The Zone Board has a 4 pin connector cable that is to be connected through a connector cord (supplied) to the matching 4 pin connector cable from the Space Heating Module itself.

Cabin Fan Leads

- The Zone Board has two color coded connecting leads for the space heating cabin fan heater.

Thermostat Leads

- The Zone Board has two color coded connecting leads for connection to the space heating thermostat.

Fuses

- The Zone Board has one ten amp fuse for the cabin fan, a one amp fuse for the thermostat and the remainder are five amp fuses for the distribution pumps.

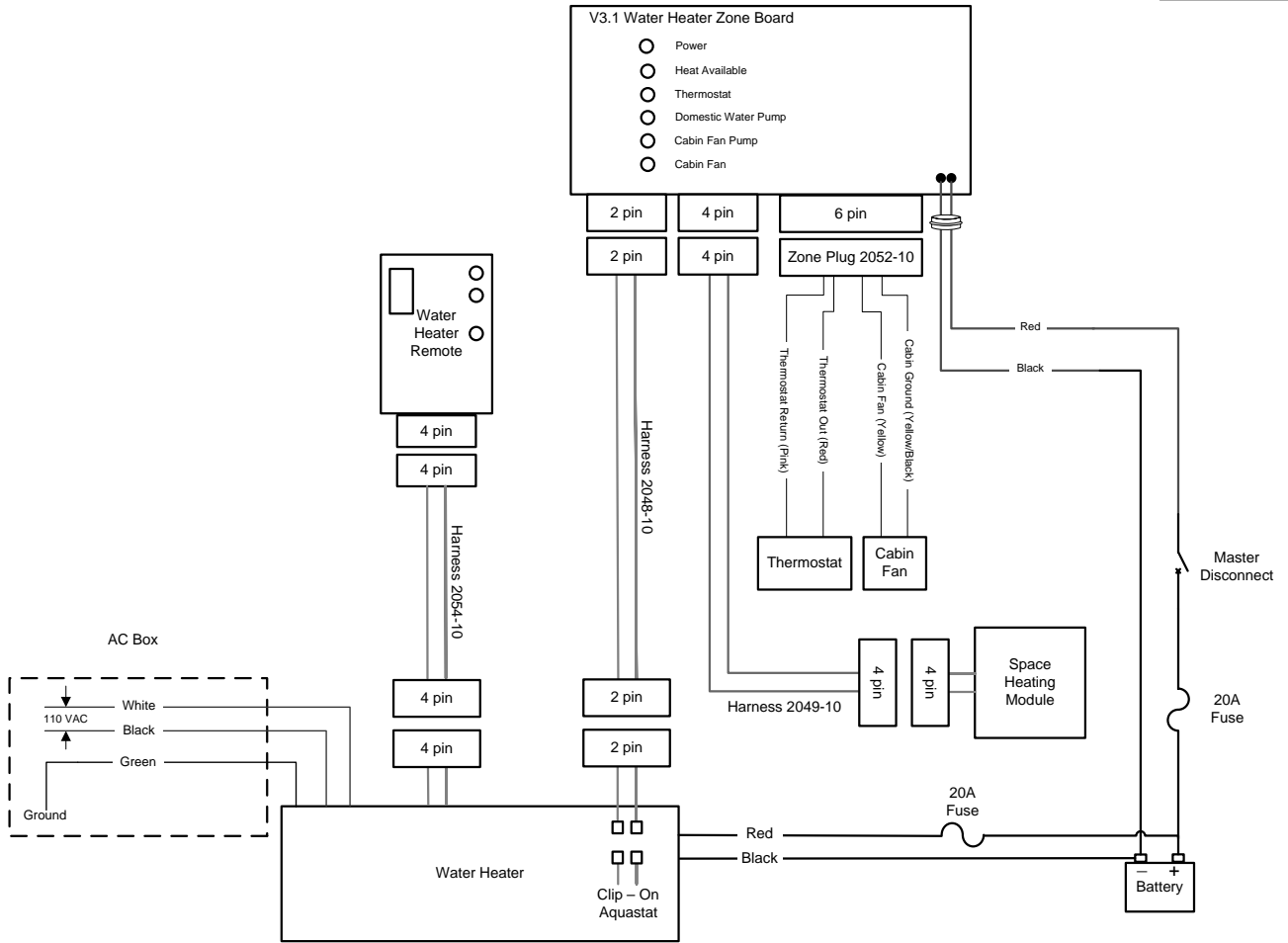

Figure 9-3: Space Heating Module and Zone Board Electrical Hookup



9.8 What NOT to Do

- **Don't** over tighten the mounting lock nuts.



9.9 Procedure

After choosing the mounting location for the Space Heating Module:

- 1 Mount the Space Heating Module vertically and level.
- 2 Secure the Space Heating Module in place (against the wall, floor, or a mounting platform) using four(4) x 1/4" through bolts and 1" diameter fender washers, lock washers and nuts .

9.10 INSPECTION AND TESTING

After all components have been properly installed according to ABYC Industry Standards and Practices and the recommendations of this Manual, the Space Heating Module and The WaterHeater™ by ITR should be inspected using the **Inspection Check Sheet** in this Manual. The **Inspection Check Sheet** is divided into relevant sections allowing each phase of the Inspection to be carried out systematically, and then signed off by authorized personnel.



Warranty Information

Attention Purchaser and Installer

NOTICE

No warranty covers damage or failure of the heater, hot water heater, heating module, distribution module, or space heating module (collectively, "the Product") or to the vehicle in which it is installed, due to unapproved, unauthorized, or improper installations of the Product. Use of any unapproved materials or equipment in the Product's installation or operation will result in a voided warranty for the entire heating system.

- You must install the Product in compliance with the specifications, standards, and instructions in the *Installation Manual*.
- If you need to depart from the manual, you must first consult and obtain the written approval of ITR. Otherwise, your warranty may be voided or limited.
- Systems that are not installed to the published installation instructions (unless with prior written approval of ITR) will be ineligible for warranty coverage.
- Fill in the enclosed Warranty Card completely. It must be signed by the Owner and returned to ITR within 30 days of the date of the original installation. The Owner cannot transfer this warranty. Before mailing, make photocopies of the completed Warranty Card for your records. It will be a valuable reference if you need warranty repairs in the future.

General Warranty

ITR warrants all water jackets or coolant jackets in the Products to be free of defects in materials and workmanship under design usage and service conditions for three (3) years from the date of the sale to the original retail owner or three thousand (3000) hours of operation of the Product, whichever comes first.

ITR warrants the water tank in the Hot Water Heater to be free of defects in materials and workmanship under design usage and service conditions for two (2) years from the date of the sale to the original retail owner or two thousand (2000) hours of operation of the Product, whichever comes first. All other accessories and components supplied or installed in the heater will be covered by the lesser of the accessory and component manufacturer's warranty or a period of two (2) years or two thousand (2000) hours from the date of the sale to the original retail owner of the Product. Warranty replacement parts are covered for the remainder of the Product's warranty or ninety (90) days, whichever is greater. At ITR's discretion, coverage for warrantable parts may be made to the Owner in the form of repair, replacement, or credit.

Limited Warranty

The following warranties are in lieu of all other warranties and conditions. ITR makes no other warranties, representations, or conditions, express or implied. Expressly excluded are all implied or statutory warranties or conditions of merchantability of fitness for a particular purpose, and those arising by statute or otherwise in law or from dealing or trade usage.

The stated express warranties are in lieu of all liabilities or obligations for damages arising out of or in connection with the delivery, use, performance, or licensing of the Product or in connection with any services performed. In no event whatsoever will ITR be liable for indirect, consequential, exemplary, incidental, special, or similar damages, including but not limited to, lost profits, lost business revenue, failure to realize expected savings, other commercial or economic loss of any kind or any claim against ITR by any other party arising out of or in connection with the sale, delivery, use, performance, or repair of the Product, or in connection with any services performed, even if ITR has been advised of the possibility of such damages, whether based upon warranty, contract, or negligence. ITR's maximum liability shall not in any case exceed the contract price for the Products claimed to be defective.

No one is authorized to increase, alter, or enlarge ITR's responsibilities or obligations under these warranties.

Owner's Responsibilities

If any warrantable failures occur before the expiration of the warranty, the Owner must give notice of such failures to ITR or to the authorized ITR dealer from which the Product was originally purchased, and obtain written approval for the warranty repair.

The Owner is responsible for the following costs in case of a warrantable failure:

- shipping and insurance costs to deliver the defective Product to the dealer or ITR (if necessary)
- all repairs made to equipment ancillary to the Product, including the vehicle, coach engine, and other associated components of the vehicle in which the Product is installed
- lodging, meals, and other incidental expenses incurred by the Owner as a result of a warrantable failure
- "down time" expenses and all business costs and losses resulting from the warrantable failure

Not Covered Under Warranty

Warranty will be voided or not extended in the following circumstances:

- Owner fails to notify ITR or the authorized ITR dealer from which the Product was originally purchased about a warrantable failure and to obtain prior written approval for warranty repair.

- Original serial number on Product or electrical control board has been removed, altered, or is unreadable.
- Product has been modified or uses non-standard parts not approved by ITR.
- Product has been abused (such as by dropping it), damaged, vandalized, or has received improper maintenance.
- Product has been run dry or operated without appropriate antifreeze, causing damage to the heat exchanger, pump seals, etc.
- Product has been exposed to an environment detrimental to its effective operation, such as excessively wet, dirty, or hot areas.

Also not covered under warranty:

- Parts or Products no longer within the manufacturer's warranty period.
- Parts or Products installed or used in a manner contrary to ITR's printed instructions without ITR's prior written permission.
- Normal wear and tear of parts, including but not limited to, fuel filter, air filter, nozzles, fuses, ignitor, electrical motors, fuel pumps, air compressors, and carbon brushes.
- Product malfunctions due to improper installation of parts or Products, including but not limited to malfunctions causing inadequacies in air, fuel, or coolant flow; voltage problems due to improper wiring; and shock or vibration.
- Progressive damage to the engine or vehicle caused by failure of the Product or an improper installation.
- Diagnosis or repairs to fix problems not directly related to the Product or due to empty fuel tanks or poor fuel quality, fuel additives, acidic water, electrolysis, or any chemical reactions.
- Travel time and expenses by an ITR dealer.
- Removal and re-installation expenses for the ITR heater.

Customer Service Calls

ITR warrants the ITR heater and the Dealer warrants the installation.

If you have a service problem, first check the *Troubleshooting* section of the *Owner's Manual* to determine if your problem is addressed. Also ensure you are familiar with the design and installation setup.

When calling ITR or the Dealer with a service problem, have the following information ready at hand:

- model number and serial number of the Product
- a detailed description of the problem
- your *Installation Manual* and *Owner's Manual*

Depending on your location, an authorized service person may be able to visit your coach or yacht to help troubleshoot problems and repair your Product. Such service calls are at the Owner's expense. Regardless, you must obtain written approval from ITR or the Dealer for any warranty repair before it is undertaken. All repairs done under warranty are subject to the terms and conditions of the flat-rate manual.

Returns

If a service call by an authorized service person is not feasible, the Owner must do the following to obtain warranty service:

1. Immediately contact ITR (or your Dealer) and provide a full description of the problem.
2. Obtain (in writing) a Return or Repair Material Authorization (RMA) number from ITR for any warranty, return, repair, or service. ITR will refuse any return package and will not authorize service or repairs without a RMA number. (For repairs by authorized Dealers, the dealer must obtain an authorized RMA number from ITR before warranty work commences.)
3. When shipping your Product, pack securely, show the RMA and serial number of the Product on the outside of the shipping container, and ship prepaid and insured.
4. Provide written details of the problems, date of installation, proof of purchase, and a return address.

After repair or replacement of the Products still under warranty, ITR will pay return shipping charges. Factory repairs or replacement will be done as quickly as possible, with an estimated turnaround of five working days. All repairs done under warranty are subject to the terms and conditions of the flat-rate manual.

Telephone / Email Service

There is no charge for help or service information given over the telephone or by fax or email. However, any informal advice or recommendation from ITR employees or Dealers is given only in good faith as an accommodation to the customer. Such information should not be relied upon without an independent verification of its applicability to the customer's particular situation. For customer service or other information, contact:

IN CANADA:

2431 Simpson Road

Richmond, BC, Canada V6X 2R2

Tel: 1-800-755-1272 or 604-278-1272

Fax: 604-278-1274

Email: itr@shaw.ca

Website: <http://www.itrheat.com>

IN THE UNITED STATES:

Suite 260, 600 SE Maritime Ave.

Vancouver WA USA 98661

Tel: 1-800-993-4402 or 360-993-4877

Fax: 360-993-1105

Email: info@itrheat.com