



# Prospector

*SPACE HEATER*



## Installation and Operating Manual



CERTIFIED TO CSA AND UL STANDARDS

# Table of Contents

Table of Contents .....	i
Table of Contents .....	ii
Overview.....	1
1. Safe Operation .....	1
2. DOs and DO NOTs .....	2
3. Components.....	4
4. Installation .....	6
5. Operation .....	12
6. Oil Control Valve.....	14
7. Maintenance .....	15
8. Trouble Shooting .....	16

**READ THESE INSTRUCTIONS AND SAVE FOR FUTURE REFERENCE**

# Overview

Make sure you read and understand this manual before installing and operating your *Prospector*. If you have any questions, or require any explanation, please contact your authorized ITR dealer.

Thank you for purchasing International Thermal Research's (ITR) *Prospector* space heater.

The *Prospector* Heater is a vaporizing-type oil burner space heater with a simple, effective design that produces radiant and convection heat through the efficient combustion of liquid fuel. With regular maintenance and proper operation your heater will function satisfactorily for many years.

The heat output range for your *Prospector* heater is 20,000 to 55,000 BTU's. This is sufficient capacity to heat areas such as cabins, workshops, small warehouses, etc.

Table 1: General Information

Nominal heat output	Oil Consumption		Chimney draught		Weight	Flue diameter
	min	max	min	Max		
55,000 BTU/Hr	0.32 US Gal/h	0.55 US Gal/h	.050" W.C.	.060" W.C.	58 Lbs	Ø6 inches
16,1 kW	1,20 Liter/h	2,10 Liter/h	12,5 Pa	15 Pa	26 kg	152,4 mm

## 1. Safe Operation

Proper installation, operation and maintenance procedures laid out in this manual, as well as local government requirements, must be followed to insure the safe operation of your *Prospector*. CSA standard B139, Installation Code for Oil Burning Equipment, UL896, or NFPA#31 are standards that apply to this equipment.

Make sure you read, and understand these instructions and save them for future reference. If you have any questions or don't understand anything in this manual, contact your authorized ITR dealer.

## 2. DOs and DO NOTs

All heaters must be installed according to the installation rules mandated by local, state/provincial and federal government authorities. These regulations deal with various matters including heater and flue set backs and fuel storage. **DO** determine what regulations apply in your local area. **DO NOT** install the heater or flue unless installation conforms with the regulations governing your location.

All heaters and stoves, whether they burn solid or liquid fuel, exist for one reason – to produce heat. Therefore common sense says that all heater parts will be hot when the unit is operating. **DO NOT** touch heater parts if the heater is running. You'll get burned.

Your heater is designed to burn clean #1 and #2 diesel fuel. If you burn any other fuel or burn contaminated diesel, you will void your warranty, cause damage to the fuel control valve (Toby) and may cause a fire or even an explosion. **DO** use only the right fuel. **DO NOT** use any other fuel, under any circumstances.

Fuel delivery from the tank to the heater is important. Any fuel leaks can result in a dangerous fire. **DO** inspect the entire fuel line for leaks before firing the heater. **DO NOT** start the heater until any leaks are properly fixed.

Because of the unique vaporizing design of the heater, correct draft conditions are essential for the heater to operate in a satisfactory manner. **DO** check the draft on the setup of the heater by using a draft meter and ensure the heater is operating under the recommended setting. If a draft meter is not present, the draft conditions **MUST** be estimated. See the details in the manual for estimating the draft conditions.

All fuel burning heaters require oxygen to operate and they get that oxygen from the air. **DO** inspect the space below the burner to make sure there are no blockages and, if there is any dust or dirt remove it. **DO** inspect the exhaust flue (stove pipe) to make sure it is not blocked. **DO NOT** start the heater until any blockages have been removed.

Oxygen for combustion comes from the air in the same space as the heater and as that air is used in the combustion process it goes up the exhaust flue. Since you are also in the same space as the heater, if the air in the room is not replaced, all the oxygen needed to keep the heater burning, and you alive, will run out. **DO** make sure that you have a window or door opened a bit to allow fresh air to enter. **DO NOT** operate the heater in an air tight room. To do so will lead to oxygen deprivation and, if the condition continues, will result in death.

During shipping, the S-tube may become dislodged from the center fuel up tube. If the S-tube has become dislodged, which can be seen through the glass on the lid, the top of the heater must be removed to position the S-tube over the fuel up-tube. **DO NOT** operate the heater without initially checking the position of the S-tube.

**DO NOT** operate the heater without both a complete exhaust stack in place and correct draft conditions. Excessive carbon will form in the fuel up-tube and will have to be cleaned out for the heater to function correctly.

**DO** mount the heater securely to a non-combustible floor. If a heater is not solidly secured, and it gets knocked over, it will spill the burning fuel all over the floor. This will create a serious fire hazard that could burn down the building housing the heater. **DO NOT** start the heater until it is properly secured.

All liquid fuel heaters run best when they are level. **DO** make sure your heater is level before you start it.

If, after the heater has been fired, you smell smoke or exhaust fumes, shut the heater down immediately and examine the stove pipe for leaks or loose fittings. **DO NOT** continue to operate the heater until any leaks are repaired. The fumes are poisonous. **DO** vent all exhaust gases outside.

**DO NOT** ever attempt to relight the heater when it is hot. If the unit is shut down for any reason **DO** wait until it cools down to room temperature before re-firing.

All heaters, regardless of the type or make, can malfunction and all manufacturers recommend that heaters are not left running unattended. **DO NOT** leave the heater running unattended. The *Prospector* is mechanically capable of operating unattended, but if there is a malfunction ITR accepts no responsibility or liability for any damage caused, regardless of the type or extent of the damage. **THIS PARAGRAPH CONTAINS LANGUAGE THAT LIMITS THE MANUFACTURER'S LIABILITY.**

**DO** install carbon monoxide and smoke detectors in the same room as the heater;

The Canadian Standards Association (CSA) has some additional consumer tips for space heaters.

Some of those tips are:

**DO NOT** hang wet clothing above the heater to dry it. The clothing can catch fire as it dries

**DO** supervise young children when in the same room as the heater

**DO NOT** keep gasoline, solvents or other flammable or vapourizing liquids in the same room as the heater.

More tips can be found on [http://www.csa.ca/consumers/consumer\\_tips/](http://www.csa.ca/consumers/consumer_tips/).

### 3. Components

#### A.) *Prospector* major external components

**Heater Shell (1)** – The heater shell assembly is the area of the heater containing the perforated burner shell.

**Top Lid (2)** – Contains a sight glass to observe the flame.

**Guard (3)** – Perforated shield surrounding the *Prospector*

**Valve Heat Shield (4)** – Shield between control valve and burner shell.

**Toby Oil Control Valve (5)** – Located on the side of the heater and controls the amount of gravity fed fuel supplied to the burner. Turning the control knob will allow more or less fuel to enter the burner. See sections 5 & 6.

**Drain Valve (6)** – To fill up the primer cup or to drain fuel from the control valve.

**Fuel Connection (7)** – ¼" NPT female threaded fitting

**Fuel shut off valve (8)** – Opens or closes the flow from the fuel tank to the Oil Control Valve .

**Flue Collar (9)** – To attach a Ø6" Flue stack.

**Reamer Tool (10)** – To clean the Up-Tube from soot and carbon build up.

**Primer Cup (11)** – Attached with a chain and used to start-up the heater.

**Removable Handle (12)** – Used to open the lighting port or top lid. Do not leave the handle on the unit when heater is running. Handle gets too hot to touch.

**Draft regulator (13)** – To maintain a stable draft

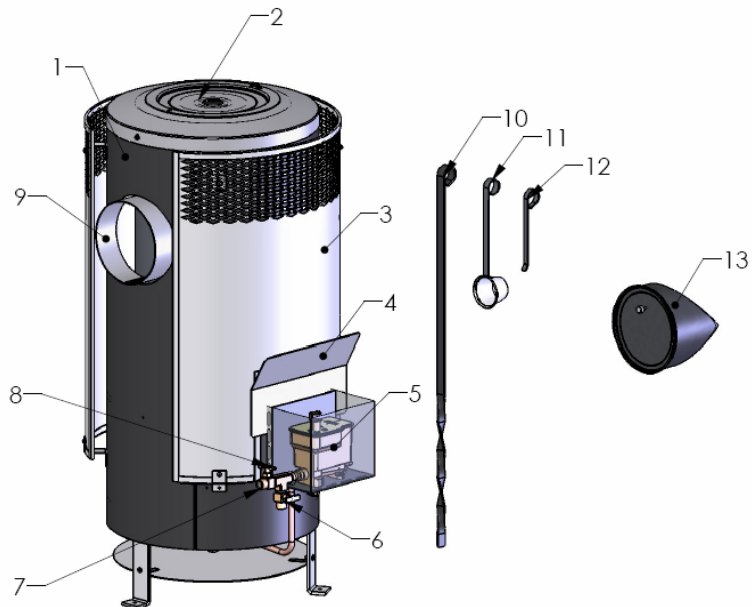

## B.) *Prospector* major internal components

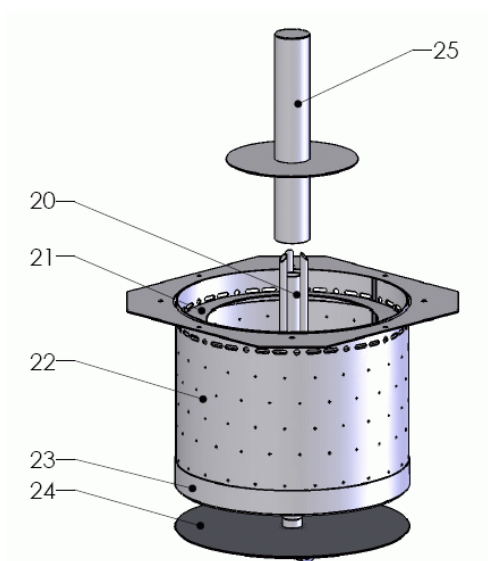

**Up-Tube (20)** – Receives fuel from the oil control valve and permits fuel vapours to flow into the S-Tube (25) during operation.

**High Fire Ring (21)** – Clean below High Fire Ring periodically, remove any build up of soot or hard carbon deposits and vacuum.

**Burner Shell (22)** – Area of the heater where combustion occurs. The perforated Burner Shell contains an up-tube (20) welded to the base of the shell and a removable, capped S-Tube (25) which sits over the welded up-tube. The Burner Shell is permanently mounted inside the Burner Shell Assembly (1) and can be accessed by removing the Top Lid (2).

**Burner Base (23)** – Bottom of Burner Shell (22). Periodic cleaning from soot and carbon build up required.

**Burner Heat Shield (24)** – Heat shield to keep heat inside the Burner Shell and away from the bottom of the *Prospector* Unit.

**S-Tube (25)** – The large capped tube in the center of the perforated Burner Shell is the S-Tube. During shipping, the S-tube may become dislodged from the center fuel up tube (20). If the S-tube has become dislodged, which can be seen through the glass on the lid, the top of the heater must be removed to position the S-tube over the fuel up-tube. **DO NOT** operate the heater without initially checking the position of the S-tube.

During operation, fuel flows through the Up-Tube (20) where its level is gravity maintained with the Toby Control Valve (4). Fuel vaporizes due to combustion heat and is expelled from the up-tube, down through the S-tube and into the perforated burner shell where it ignites.

Note: If any parts appeared damaged, do not operate the heater. Contact your authorized **Prospector** Dealer.

When unpacking the heater, remove any packing material from the side of the burner canister and around the air intake area.

## 4. Installation

### A.) Location and Mounting

The **Prospector** heater may be placed on a flat level surface made of material that can resist heat. Hardwood, plywood, concrete, etc. are acceptable. The **Prospector** should not be mounted directly on a carpeted floor. Use a solid platform or rigid heat resistant material between the carpet and the heater.

Ideally a large open space would best suit the heater. The surfaces of the heater and the flue stack will be generating heat and should be taken into consideration when mounting the heater.

The minimum standard clearance between the heater and any building construction other than the floor is 36 inches (91 cm). The minimum standard clearance between the exhaust vent pipe and any building construction is 18 inches (45 cm).

An unlevelled heater will not operate properly and could be dangerous. **Adjust the heater perfectly level in all directions before mounting.**

The heater should be securely mounted to the floor. The legs contain a  $\frac{1}{4}$ " hole for directly fastening the heater to the floor.

### B.) Exhaust Flue Stack and Draft

**OIL BURNING APPLIANCES MUST BE CONNECTED TO FLUES HAVING SUFFICIENT DRAFT AT ALL TIMES TO ENSURE SAFE AND PROPER OPERATION OF THE BURNER.**

All heaters must be installed according to the installation rules mandated by local, state/provincial, and federal government authorities. These regulations deal with various matters including heater and flue set backs and fuel storage. **DO** determine what regulations apply in your local area. **DO NOT** install the heater or the exhaust flue stack unless the installation conforms with the regulations governing your location.

The **Prospector** does not come with an exhaust flue stack. Blue stove pipe or All-Fuel "L" type vent capable of continuous use for flue gas temperatures up to 1000 °F may be used. Always use a 6 inch diameter, ninety degree elbow off the heater. Attach a 90 degree elbow directly to the heater. The non crimped end of the exhaust elbow is designed to slide over the heater exhaust collar. Fix the

elbow to the heater collar. Attach a minimum of three feet of the same 6 inch diameter flue stack to the elbow. After this point, you may transition into a larger diameter stack. Appropriate parts for the appropriate flue stack must be purchased at your local heating and ventilation companies. As all installations differ, it is necessary that you follow all local, state/provincial, and federal guidelines in selecting the type, method, and location of the exhaust flue stack for your particular situation.

Before hooking up the **Prospector** to a chimney flue stack (6 inch diameter), check if the chimney is in good condition and that the quality of the flue pipe will allow sufficient draft.

**DO NOT** connect horizontal exhaust stacks directly off the heater. The heater will not operate correctly and will not stay lit. The heater requires a 90 degree exhaust elbow and a minimum three foot vertical rise before further elbows and exhaust stack lengths are added. A maximum horizontal length of 3' is allowed. Make sure to have a ¼" slope rise per foot minimum. Each foot of horizontal length requires 1.5 feet of additional vertical stack height.

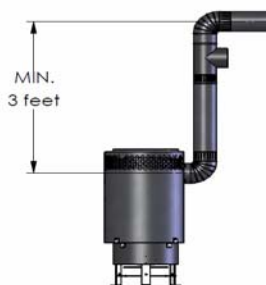

The minimum flue stack height for an angled roof with top opening exit and a vertical only flue stack is 9 feet (2.74 m). For a vertical sidewall exit with a horizontal run of three feet, the minimum vertical stack height is 13 feet (4 m).

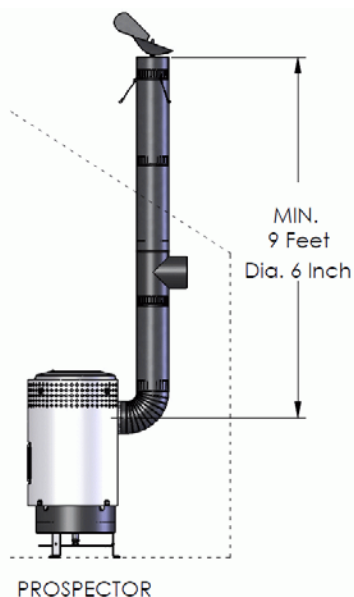

**SAMPLE EXHAUSTS:** ROOF EXIT AND SIDEWALL EXIT

**Exhaust location:** angled roof (standard configuration)

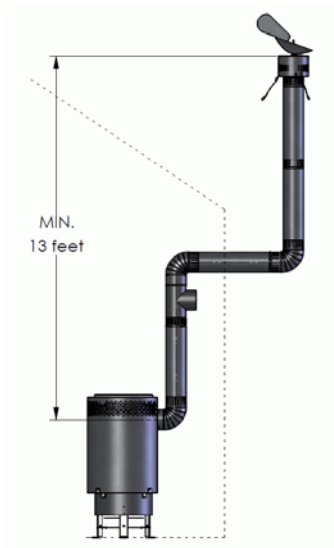

***Prospector heater with a three foot horizontal run.***

13 feet of vertical stack height in total is required versus the standard 9 feet.

**Exhaust location: vertical sidewall (optional) configuration**

The chimney flue should extend at least 2' (0.6 m) above the highest roof surface or structure within 10' (3.0 m) horizontally of the chimney to prevent down drafts.

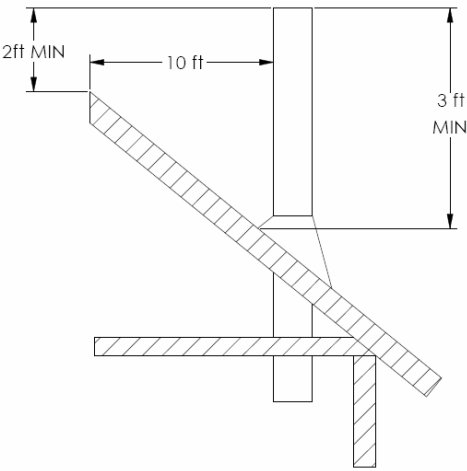

Install the included draft regulator which is necessary in order to maintain stable draft in certain conditions.

**DRAFT CONDITIONS** All heaters require the proper draft.

If a draft meter is available, set the heater to the recommended water column reading. The recommended draft for the **Prospector** is between .040-.060 inches water column. This is measured 18" (45cm) up the stack, before the draft regulator, and with the final exhaust stack configuration in place. Follow the manufacturer's instruction for the installation, location, and adjusting of the draft regulator.

If a draft meter is not available, estimate the draft (see below).

**TO ESTIMATE THE DRAFT** Set up the heater with the final exhaust stack configuration in place. Start the heater, and set the heater to **operate at the #1 setting (position indicated by the first raised notch on the fuel control valve) only**. Do not operate the heater at any other setting or the flame will be distorted. After 10 minutes of operation, view the burner flame through the glass lid on the top of the heater. Look for the level of the tips of the flame relative to the top of the S-tube. The correct draft is approximated by the flame tips at the same height as the top of the S-tube.

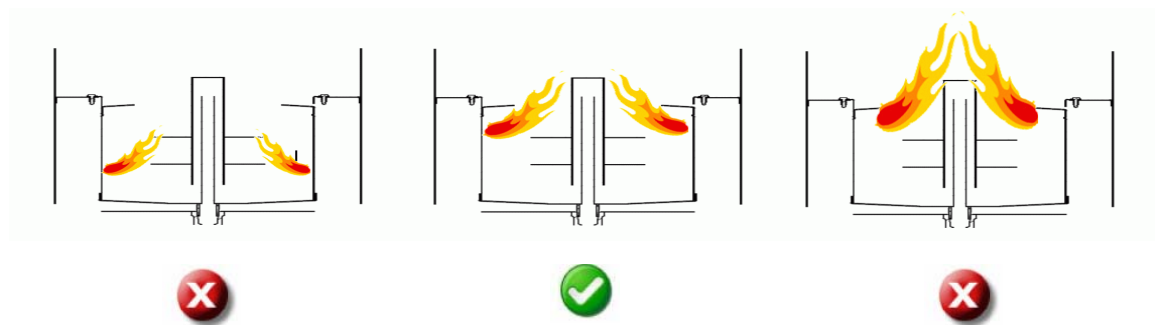

**HIGH DRAFT:**

The tips of the flame are at a level lower than the top of the "S" tube.

**CORRECT DRAFT:**

The tips of the flame are at the same level as the top of the "S" tube

**LOW DRAFT:**

The tips of the flame are at a level higher than the top of the "S" tube.

**TO ADJUST THE DRAFT** In general, the draft can be increased by increasing the existing vertical stack height. Decrease the draft by decreasing the existing vertical stack height. If a draft regulator is present, adjust the settings on the draft regulator until the desired draft setting is reached. Follow the manufacturer's instructions on use of the regulator.

The **Prospector** emits very little carbon and soot into the flue system. However it may be convenient to design your flue system so it can be brushed clean if necessary.

For safe operation, it is highly recommended that the installed exhaust system be inspected by a qualified professional to ensure the suitability of the type and method of the installation.

*During operation, the heater produces harmful carbon monoxide (CO) and other gases. To prevent CO poisoning, ensure the exhaust stack sections fit together snugly and that the exhaust gases are properly vented through the roof or sidewall.*

### C.) Venting and Air Supply

The heater consumes about 4000 ft<sup>3</sup> of air per 1 US gallon of oil. This air enters the heater through the air inlets and exits the chimney as combustion gas.

The **Prospector** should be installed in a well ventilated area that allows the entrance of outside fresh air.

### Connecting to Oil Tank

The external oil tank is to be installed in accordance with the manufacturer's instructions and the standard to which the tank has been manufactured.

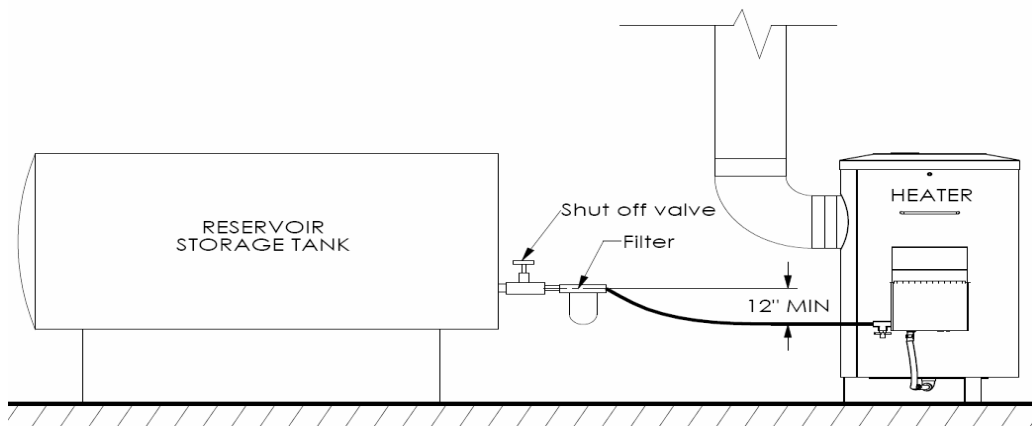

Make sure that the tank outlet is 12" (30 cm) higher than the inlet of the oil control valve (gravity fed). A good quality filter should be placed at the tank exit to ensure a clean supply of fuel.

The fuel line must be clear of any air prior to operating the heater. A fuel line kit or a solid fuel line both must be cleared of air once the fuel line is attached to the heater (shown below)

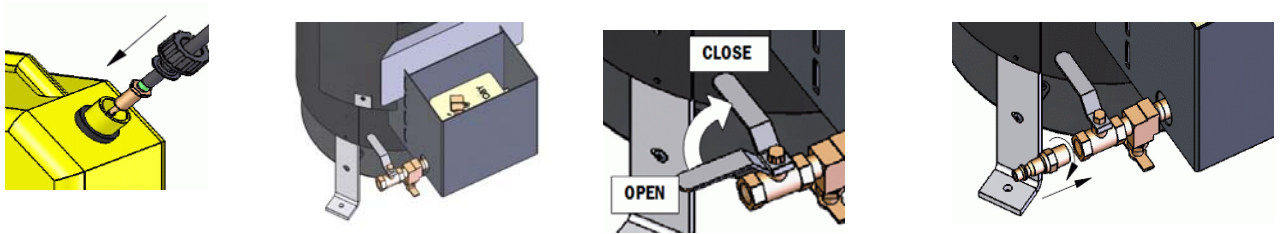

**USING A FUEL LINE KIT** Place the fuel line filter with attached hose into the fuel of the fuel tank. Remove the brass nipple from the kit and apply sealant to the threads. Screw into the ball valve fitting of the heater and tighten until leak free. Do not over tighten or the threads will be damaged and leakage may occur. Connect the fuel line to the heater using the female quick connect fitting. Turn the heater ball valve lever to the OPEN position and open the fuel drain valve. Squeeze the primer bulb until fuel flows in a steady stream from the drain valve. Catch the fuel in a separate container, then close the fuel drain valve. The fuel line is clear of air.

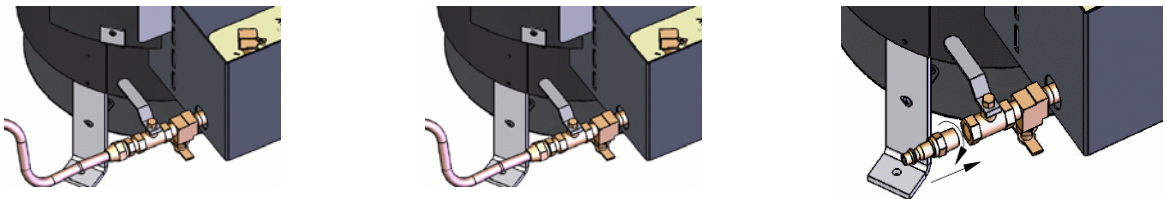

**USING A SOLID FUEL LINE** Connect the solid fuel line to the heater. Turn the ball valve lever to the OPEN position and open the fuel drain valve. Start the fuel flowing from the fuel tank and wait until fuel flows in a steady stream from the drain valve. Catch the fuel in a separate container, then close the fuel drain valve. The fuel line is clear of air.

When the fuel tank is installed outdoors in very cold temperatures, it is preferable to use #1 diesel fuel and a  $\frac{3}{4}$ " fuel line to avoid any viscosity problems.

The fuel line can be connected to the oil control valve using a  $\frac{1}{4}$ " NPT male fitting.

INSTALLATION OF THE HEATER, FLUE STACK AND FUEL TANK MUST BE INSTALLED IN ACCORDANCE WITH THE REGULATION OF AUTHORITIES HAVING JURISDICTION, NFPA #31, CSA STANDARD B139. AND UL896.

## 5. Operation

The **Prospector** heater requires a break in period between 1 and 2 hours. During this period, some smoke and fumes may be generated from the heater shell itself; make sure there is enough ventilation for the smoke and fumes to escape the living or operating areas.

### A.) Starting the **Prospector** Heater

To start the **Prospector** Heater:

**DO NOT OPERATE THE HEATER WITHOUT BOTH A COMPLETE EXHAUST STACK IN PLACE AND CORRECT DRAFT CONDITIONS. EXCESSIVE CARBON WILL FORM IN THE FUEL UP-TUBE AND WILL HAVE TO BE CLEANED OUT FOR THE HEATER TO FUNCTION CORRECTLY.**

DO NOT USE ANY UNAUTHORIZED FUELS OR MIX DIFFERENT FUELS. ONLY CLEAN UNCONTAMINATED DIESEL #1 OR #2 FUEL IS TO BE USED. USING ANY OTHER FUELS COULD CAUSE A FIRE AND/OR EXPLOSION. **DO NOT USE** GASOLINE, CRANKCASE OIL, OR ANY OIL CONTAINING GASOLINE.

- Check for any leaks in the fuel system. Locate and repair any leaks and/or clean any spills before igniting the heater.
- Check the exhaust flue stack for any blockage or anything that might obstruct the exhaust gases. The flue stack must be vented outdoors. Do not let any exhaust gas flow into any living or operating areas.
- Check the exhaust flue stack and the attachment point to the heater for any leaks. Correct any problems before igniting the heater.
- Check the airway around the base of the heater to ensure that the heater receives a clear, unobstructed supply of combustion air.
- Open the fuel shut-off valve from the fuel tank.
- Lift up on Toby Valve Actuating Lever fully and release to ensure that the fuel can run into the float bowl of the valve.
- Place the primer cup below the fuel drain valve located beside the Toby valve. Open the drain valve and allow the fuel to drain into the primer cup. Close the drain valve once the cup is full.



- Open the lighting port lid on the side of the burner shell and insert the cup inside the heater to the gap just beyond the high fire ring and before the circular plate. Pour the contents of the cup onto the burner base by turning the cup upside down. This will create a puddle of fuel at the burner bottom. Do not pour the fuel onto the ring or circular plate.



- When the burner is being lit, it is usually desirable to use a match or gas lighter and a small ball of tissue paper for lighting. Use the paper to clean the primer cup of the remaining oil and place it in the cup.



- Insert the cup with the paper inside the burner through the lighting port and position it at the same position as the "pour" position. Light the paper and turn the cup upside down so that the burning paper lands in the puddle of fuel at the bottom of the burner.

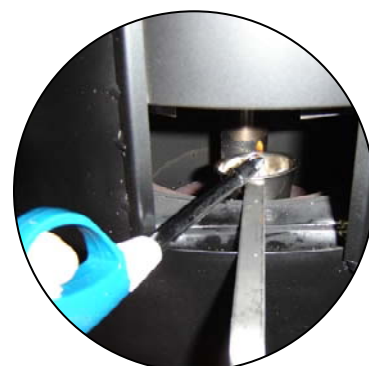

- Take the primer cup out and close the lighting port.
- Place the control knob on the Toby control valve to the first raised "I" mark setting (LOW) next to the "O" mark.
- Wait ten to fifteen minutes for the flames to settle down before setting the control knob on the Toby control valve to your desired temperature. The "0" is the OFF setting and a half turn counter clockwise is the highest fuel setting on the burner.
- If the flame dies out, wait for the heater to cool down to room temperature before repeating the starting procedures.

DO NOT ATTEMPT TO START OR RE-IGNITE THE BURNER WHEN THE BURNER IS HOT.

- Do not leave a heater running unattended. ITR accepts no responsibility for any damages caused by leaving the heater running unattended.

## B.) Turning off the *Prospector* Heater

To turn off the *Prospector* Heater:

- Turn the control knob on the TOBY Oil Valve to the OFF position marked "0" on the lid.
- Turn off the Fuel Shut Off Valve from the fuel tank to the heater.
- The flame will die out in about five minutes.

ALWAYS KEEP THE OIL VALVE TURNED OFF WHEN THE HEATER IS NOT OPERATING.

## 6. Oil Control Valve

### A.) Toby Oil Valve

The TOBY Oil Valve is a continuous flow level control valve designed for controlling fuel flow to the *Prospector* heater.

TOBY Oil Valves are factory preset to work with your heater. Do not tamper with it. If you have questions or concerns, please contact your authorized *Prospector* Dealer.

TOBY Oil Valves are very simple to operate; the key parts to operating a TOBY Valve for the *Prospector* are the Control knob and the actuating lever. The control knob controls the fuel flow rate and can be rotated counter clockwise from the off position, which is the "0" marked on the lid to the high fire position, which is the last "I" mark on the lid. The Toby Valve Actuating Lever allows fuel to run into the float bowl of the valve when it is placed in an up position.

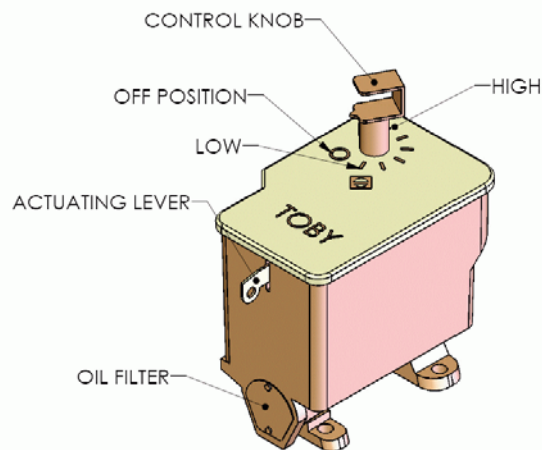

### B.) Toby Valve

safety features

The TOBY Oil Valve has two safety features incorporated into the design of the valve.

- High temperature fuel cut off system. If the temperature of the fuel exceeds 100 degrees Celsius (212 degrees Fahrenheit), fuel will be shut off at the outlet of the valve. Once this occurs, the valve is no longer operable and a new valve is required for the heater to operate.
- Tilt levelling switch. The Toby Oil Valve will shut off at the outlet of the valve when the angle of the valve exceeds the following: lengthwise 5 degrees, width wise 15 degrees.

Toby Valves are ULC Listed and DIN approved. The Toby valve requires no maintenance and has no user serviceable parts.

## 7. Maintenance

### A.) Regular Maintenance

To ensure that your *Prospector* heater operates properly;

- every 750 hours of operation or;
- if the output of the heater appears to be have decreased from the same valve setting or;
- if the exhaust exhibits smoke

perform the following maintenance:

- In normal operation, carbon and soot will accumulate in the area of the burner base, heater up tube or underneath the high fire ring. These deposits must be periodically removed.
- Working on a cold burner, ensure that the fuel control valve on the heater and the fuel supply to the heater has been turned off. Remove the burner lid and see if there is any soot around or on the perforated burner shell or high fire ring. If so, brush off and vacuum clean.
- Loosen and remove any carbon build up in the center up-tube itself. Remove the bottom heat shield. Locate the clean-out plug at the bottom of the burner shell assembly. Place the supplied fuel filler cup below the opening of the clean-out threaded plug. Use a wrench and remove the threaded plug from the bottom of the assembly. Any quantity of fuel still present in the fuel line will drain into the filler cup. Carefully insert the metal cleaning auger into the up-tube and loosen any hard carbon deposits within the tube by using an up/down twisting motion of the auger. This will loosen any deposits and allow them to fall through the opening of the threaded plug. **Do**

**not use a side to side motion or excessive force or you will distort, bend, or break the welded up-tube.** Continue until the tube is clear of any accumulated deposits. Replace the clean-out plug into the bottom of the burner shell assembly and re-tighten. A pipe sealant or other appropriate sealing compound should be applied to the threads. Check this threaded plug fitting for any leaks when the heater fuel flow is again re-started. Re-tighten if necessary.

Additional regular maintenance items include:

- Check for any leaks in the fuel system, cracked hoses or suspect areas where a leak might occur and correct.
- Check the flue stack for any damage or areas that might allow flue gases to leak into your heating area and correct.
- Check the flue stack for any blockages and/or soot and remove and correct
- Check for fuel strainer blockage and replace if necessary
- The Toby valve requires no maintenance and has no user adjustable parts

## **B.) Storing the Heater**

On storing the heater for an extended period:

- Perform the previous maintenance steps
- Clean the heater with a rag and spray or wipe with a light mist of oil inside the burner area and outside to prevent rusting.
- Drain all fuel lines and any fuel from the heater

**ATTENTION: Regular maintenance is required for the *Prospector* heater to perform as designed. Failure to maintain the heater as required will not only void your warranty but can cause the heater to be dangerous to operate.**

## 8. Trouble Shooting

### **A.) Symptom: Burner does not keep lit, flame shuts off.**

Recommendations: On a cold heater

- Check for Fuel Shut off Valve in the ON position.
- Check the Control Actuator lever on the Toby Valve and ensure it is at the on position by lifting it up fully and releasing. (This lever does not stay in the upright position during normal operation)
- Check the Control Knob on Toby Valve is not set to "0" or OFF position.
- Check for incorrect or poor quality fuel.

- Check for blockages in fuel inlet. ( i.e. fuel strainer plugged and/or fuel line to heater obstructed)
- Check for blockages in air inlet or exhaust outlet (flue stack).
- There may be air bubbles in fuel line. Give the line a quick shake to dislodge bubbles.
- Check for soot or carbon deposit that may have built up inside the up-tube, under the high fire ring, or on the perforated burner shell.

**B.) Symptom: Heater does not provide adequate heat and flame appears weak.**

Recommendation: On a cold heater

- Check for incorrect or poor quality fuel.
- Check for adequate fuel supply. Ensure the fuel supply valve is open.
- Check fuel line or fuel strainer for blockage of fuel and correct as necessary.
- Check sections of exhaust stack assembly for leakage or blockage and correct as necessary.
- Check intake opening at bottom of heater for free airflow.
- Heavy winds or other weather conditions can increase the draft of the heater. Ensure you have a draft regulator installed and it is connected properly.
- Check for soot or carbon deposit build up inside up-tube, under high fire ring, or on perforated burner shell.
- Check S-tube for proper seating on up-tube. Wait 30 minutes for heater to cool down to room temperature before checking internal tubes.

**C.) Symptom: Heater rumbles and or flame appears high on top.**

Recommendations:

- Set the Toby valve to a lower setting.
- Check for incorrect or poor quality fuel.
- Check bottom of heater for free airflow.
- Insufficient exhaust stack height could lower the draft of the heater; ensure you have the recommended draft or consult with your authorized Pioneer dealer for the need of a longer flue stack height.

**Note: If *Prospector* heater is still not functional, contact your authorized *Prospector* dealer or ITR.**

**ITR IN CANADA:**

2431 Simpson Road

Richmond, BC, Canada V6X 2R2

Tel: 1-800-755-1272 or 604-278-1272

**ITR IN THE UNITED STATES:**

11915 NE 56<sup>th</sup> Circle, Suite B

Vancouver WA USA 98682

Tel: 1-800-993-4402 or 360-993-4877