

**INTERNATIONAL LTD
THERMAL RESEARCH**

Hurricane[®] II COMBI **HYDRONIC HEATING SYSTEM**

Installation and Operating Manual

Diesel Hot Water Heating System and
Continuous Domestic Hot Water Heater for Yachts

CSA T18 R-17
ANSI/UL307A
CAN/CSA-C22.2 No.165

Copyright © October 2009

International Thermal Research

IN CANADA:

2431 Simpson Road

Richmond, BC, Canada V6X 2R2

Tel: 1-800-755-1272 or 604-278-1272

Fax: 604-278-1274

Email: info@itrheat.com

IN THE UNITED STATES:

11915 NE 56th Circle, Suite B

Vancouver, WA, USA 98682

Tel: 1-800-993-4402 or 360-993-4877

Fax: 360-993-1105

Website: <http://www.itrheat.com>

All rights reserved. No part of this manual may be reproduced or transmitted in any form by any means, electronic or mechanical, including photocopying and recording, information storage, retrieval, or transmission, without permission in writing from International Thermal Research

Right to Modify:

Due to our commitment for quality and ongoing product improvement, ITR reserves the right to modify or change without notice, any materials, applications, equipment, accessories, and/or prices. All measurements and weights are approximate.

Table of Contents

Section 1, Overview	1-1
1.1	Unpacking the Heater..... 1-2
1.2	Protect Your Warranty..... 1-2
1.3	Hurricane II® Combi Features..... 1-3
1.4	Critical Factors..... 1-5
1.5	Equipment, Tools and Skills..... 1-6
1.6	Testing and Inspection..... 1-7
Section 2, Mounting the Hurricane II® Module	2-1
2.1	Before You Begin..... 2-1
2.2	Your Mounting Location..... 2-2
2.3	What NOT to Do..... 2-4
2.4	Procedure..... 2-4
Section 3, Installing the Exhaust System	3-1
3.1	Before You Begin..... 3-1
3.2	Mounting Location..... 3-1
Recommended Exhaust Outlet Locations.....	3-1
Recommendation for Installation.....	3-2
What NOT to Do.....	3-3
3.3	Procedure..... 3-4
Section 4, Installing the Fuel System	4-1
4.1	Before You Begin..... 4-1
4.2	Fuel System Operation..... 4-1
Recommendations for Installation.....	4-1
4.3	What NOT to Do..... 4-2
4.4	Procedure..... 4-3
Section 5, Installing Fan Heaters	5-1
5.1	Before You Begin..... 5-1
5.2	Fan System Operation..... 5-2
Features.....	5-2
Multiple Zone Heating.....	5-3
Accessories and Components Needed.....	5-4
5.3	What NOT to Do..... 5-4
5.4	Mounting Locations..... 5-5
5.5	Procedure..... 5-5

Section 6, Wiring the Electrical System	6-1
6.1	Before You Begin 6-1
6.2	12 VDC..... 6-1
6.3	120 VAC 6-2
6.4	Remote Operating Panel Cable 6-2
6.5	Zone Connections..... 6-2
6.6	Main Electronic Control Board 6-4
6.7	What NOT to Do..... 6-4
Section 7, Plumbing the System	7-1
7.1	Before You Begin 7-1
7.2	Plumbing Installation 7-1
7.3	Engine Waste Heat Option..... 7-6
7.4	Engine Preheat Function..... 7-6
7.5	What NOT to Do..... 7-8
7.6	Filling and Purging the system 7-8
7.7	Hot Water Temperature Adjustment.....7-10
Section 8, Operating the Hurricane®II Combi	8-1
8.1	Operating Instructions for the Hurricane®II Combi 8-3
8.2	Turning the Power to the Hurricane®II Combi ON..... 8-4
8.3	Activating the Burner (Primary) and AC Heat (Secondary) from the Remote Operating Panel..... 8-5
8.6	Activating the Cabin Fan Heaters through the Thermostats 8-6
8.7	Activating the Domestic Hot Water 8-6
8.8	Activating the Engine Heat 8-6
8.9	Functions of the Remote Operating Panel..... 8-7
8.10	Functions of the Heater Control Panel..... 8-9
8.11	Maintenance.....8-10
8.12	Protecting the Hurricane®II Combi.....8-11
8.13	General Troubleshooting8-12

Warranty Information & Warranty Card

List of Figures

Figure 1-1	Hurricane® II Combi	1-1
Figure 1-2	Hurricane® II Heating System Plumbin	1-4
Figure 2-1	Hurricane® II Combi Dimensions	2-3
Figure 2-2	Hurricane® II Combi Mounting Brackets.....	2-4
Figure 3-1	Installing the Exhaust System.....	3-5
Figure 4-1	Fuel Connection Schematic	4-3
Figure 5-1	Wiring the Fan's Aquastat.....	5-3
Figure 5-2	Mounting a Spacesaver Fan	5-6
Figure 5-3	Installing a Relay for Add'l Fan Amperage....	5-6
Figure 6-1	System Wiring	6-3
Figure 7-1	Hurricane® II Combi and cabin fans	7-2
Figure 7-2	Three Approved Methods of Installing Heater Hose	7-3
Figure 7-3	Hurricane® II Combi Heating System	7-3
Figure 7-4	Domestic Hot Water System Plumbing.....	7-5
Figure 7-5	Engine Heat Exchanger Plumbing	7-8
Figure 7-6	Initial Fill Up	7-9
Figure 7-7	Mixing Valve Location	7-10
Figure 8-1	Hurricane® II Combi Heating System	8-1
Figure 8-2	Hurricane® II Combi Main Control Panel	8-2
Figure 8-3	Location of the Summer/Winter Valve	8-4
Figure 8-4	Remote Operating Panel.....	8-5
Figure 8-5	Zone Control Board	8-7

Table of Contents

Overview

Thank you for purchasing the Hurricane®II Combi Heating System.

NOTICE

The Hurricane®II Combi Heating System has been designed to meet ABYC standards for installation into Yachts.

This section covers critical information you need to know before beginning the installation including how to protect your warranty, and tools and equipment needed.

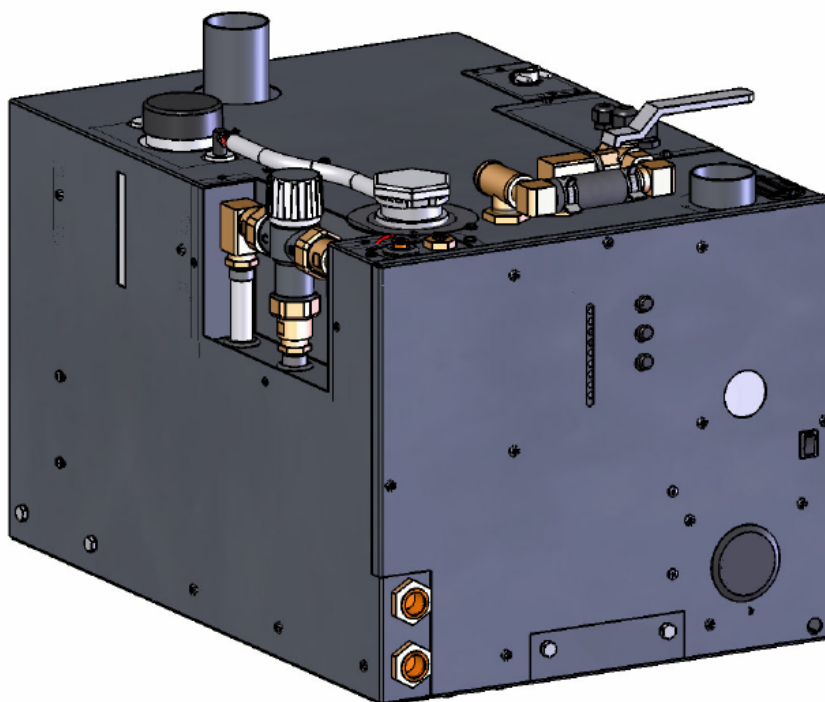

Figure 1-1: Hurricane®II Combi Heating System

1.1 Unpacking the Hurricane®II Combi Heating System

When you receive the Hurricane®II Combi Heating System:

- 1 Unpack it carefully.
- 2 Check each component against the shipping list to ensure that you have everything and that all parts arrived undamaged.
- 3 If you discover any missing or defective parts call ITR immediately.
- 4 If you are not installing the Hurricane®II Combi Heating System right away secure all components so none will be misplaced.
- 5 **Before installing the Hurricane®II Combi Heating System read the rest of this Installation and Operating Manual. It contains critical information for a proper installation.**

A properly installed Hurricane®II Combi Heating System is essential for several reasons:

- To ensure that you and/or your customers receive satisfactory results and enjoy a warm, comfortable environment.
- To ensure a trouble-free installation, a successful inspection and testing process, and ease of future maintenance.
- To protect your warranty.

1.2 Protect Your Warranty

This document reflects approved installation techniques, methods, and materials, and applies only to ITR equipment. The Hurricane®II Combi Heating System is only guaranteed by ITR if the entire system has been installed according to the requirements and recommendations set out here.

This does not include:

- Deviations from the instructions in this manual.
- Changes to any piece of ITR-supplied equipment.
- Substitution of a non-ITR approved component.

No warranty will be extended to improper installations. Use of any unapproved materials, equipment or installation procedures will result in a voided warranty for the entire heating system. Any loss of service or damage as a result of any unapproved modification is the responsibility of the installer. ITR accepts no liability for any damage or loss of service resulting from unapproved modifications.

- Efficient
- Clean
- Quiet
- Compact
- Safe
- Rugged
- Reliable
- Economical

1.3 Hurricane®II Combi Heating System Features

The Hurricane®II Combi Heating System uses a diesel burner (12 VDC) controlled by a multi-functional electronic controller as the primary source of heating coolant fluid (anti-freeze and water). One 1500 Watt, 120 VAC immersion element is used as secondary heat source. The Hurricane®II Combi Heating System heats the coolant fluid to provide a source of heat for all hydronic space heating needs. The Hurricane®II Combi Heating System has the ability to circulate the coolant fluid to all space heating areas. It can also provide a supply of domestic hot water using the integral heat exchanger.

Other features of the Hurricane®II Combi Heating System include:

- A high-temperature, stainless steel burner and stainless steel jacket.
- 4.0 US gallon welded, insulated stainless steel coolant tank that minimizes heat loss and optimizes heat recovery.
- Low coolant level switch.
- Easy to install and field serviceable with the hookups and connections easily accessible from the front and top of the Heating System.
- Quiet operation and low power consumption.
- Low pressure fuel system with built-in fuel pump.
- Fuel efficient burner capable of burning a wide variety of diesel-based fuels.
- Exhaust has minimal smoke and smell.

- Fan assisted sealed combustion chamber is designed to use outside combustion air.
- Simple, low amperage draw ignition.
- Electronically-controlled system with:
 - automatic Safety Shutdown;
 - overheat safety protection.
 - LED indicators on the Control Panel for diagnostics.
 - Patented, proprietary flame sensor.
- Heating System Remote Operating Panel with ON/OFF switch for the diesel burner and Electric element.
- Heating System Control Panel with buttons for Power, Bypass, Reset, and indicator LED's for operational and diagnostic information.
- Built in distribution pump and heat exchanger for heating multiple zones and also producing domestic hot water. The Zone Board Controls up to three space heating zones.

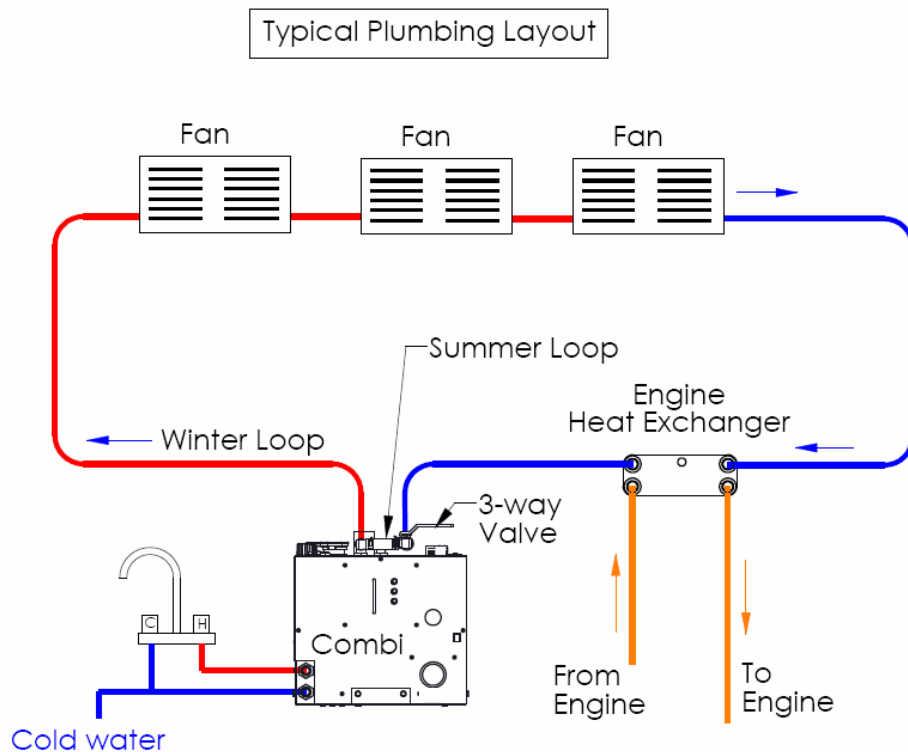

Figure 1-2: Hurricane®II Combi Heating System Plumbing

1.4 Critical Factors

THE INSTALLATION SHALL BE IN ACCORDANCE WITH THE REGULATIONS OF AUTHORITIES HAVING JURISDICTION

Pay attention to the notices of "Danger" "Warning" "Caution" and "Notice" in this manual.

The key factors to keep in mind when planning and carrying out the installation are:

- Mounting location restrictions for the Hurricane®II Combi Heating System and exhaust outlet (to reduce noise, vibration, heat loss, etc.).
- Length, routing and sizing of fluid lines, fuel lines, air-flow tubing, exhaust piping and wiring.
- Unrestricted vent required to draw in 100% outside air for combustion.
- Ability for technician to easily access and service the product, especially fuel, plumbing, and electrical systems.
- After installation, ability to purge the coolant and fuel lines and inspect/test entire system using the ITR-supplied Inspection Check Sheet.

1.5 Equipment, Tools and Skills

As the user and/or installer, you must be qualified and authorized to do the installation, which requires mechanical aptitude and electrical knowledge. Make sure you comply with existing ABYC industry practices, using the highest and most recent standards and codes. Good workmanship is essential. Please refer back to *Section 1 – Overview, sub-Section 1.2, Protect Your Warranty*.

You will need the following equipment and tools to install the heating system (not supplied). This list does not include optional equipment and accessories:

- Standard tools normally available in a well-equipped shop.
- Approved fasteners for mounting the heater unit.
- Stainless steel 2" ID exhaust system piping, maximum 12' with no bends. (See *Section 3 – Installing the Exhaust System*, for details when bend are present.).

- Exhaust collar.
- ITR-muffler with straight-through design.
- 1/4" supply fuel line, approved rubber or copper.
- #10 sheet metal screws or wood screws to mount fan units inside the occupied areas.
- Heater hose (to connect to interior fans).
- Domestic water hose and/or tubing to connect to the domestic water system.
- Up to three (3) thermostats (DC compatible) to allow temperature regulation of the heating zones.

1.6 Testing and Inspection

After all components have been properly installed according to standard practices, ABYC standards, and the recommendations of this Installation and Operating Manual, the Hurricane®II Combi Heating System should be test-operated for inspection purposes.

For your convenience, you can use the pullout *Inspection Check Sheet* in this Manual. The Inspection Check Sheet is divided into progressive sections, allowing each phase of the inspection to be carried out systematically, and then signed off by authorized persons.

Mounting – Hurricane® II Combi Heating System



2.1 Before You Begin

Plan the location of the Hurricane® II Combi Heating System and all its major components in advance to ensure the chosen locations are compatible with installation requirements and within the technical specifications.

Consider the following factors to help you decide exactly where best to mount the Hurricane® II Combi Heating System:

- Hurricane® II Combi Heating System weight when full (115 lbs).
- Ventilation requirements.
- Exhaust outlet location and maximum acceptable length.
- Thru hull location and water line.
- Potential for vibration and jarring.
- Length of run from fuel source to heater.
- Most efficient plumbing runs.
- Safe and convenient access for maintenance.
- Number and location of interior fans.

! WARNING

Make sure you are familiar with *Section 1 – Overview* of this Manual. If the system is not installed according to specifications and with the correct equipment, your Hurricane®II Combi Heating System may not operate properly, safety may be compromised, and your Warranty may be voided.



2.2 Your Mounting Location

Your mounting location should consider the following:

- Mounting location must be able to support double the gross weight of the Hurricane®II Combi Heating System (i.e. 115 lbs. x 2 = 230 lbs./48 KG x 2 = 96 KG) and must be of a non-combustible and non absorptive surface.
- Hurricane®II Combi Heating System is 14"H x 16"W x 23" D. (35.6 cm x 40.6 cm x 58.4 cm), see *Figure 2-1: Module Dimensions*.
- Hurricane®II Combi Heating System must be installed in a compartment which is completely isolated from the atmosphere of living spaces.
- Combustion air must be drawn from an outside source and cannot contain any combustible gases.
- Hurricane®II Combi Heating System must be mounted in an area that provides a minimum of 12" of unrestricted access to the front panel. Allow space for connection to the fuel and coolant lines, as well as the power and exhaust connections (Minimum of 6" top clearance). Allow 1" clearance on the sides for attaching the mounting brackets. The bottom and back surfaces have no clearance requirements.
- Mount the unit with the front panel side facing out and accessible. Facing out simplifies installation and maintenance.
- Hurricane®II Combi Heating System must be mounted horizontal and level using three, 1/4" through bolts and 1" diameter fender washers, lock washers and nuts.

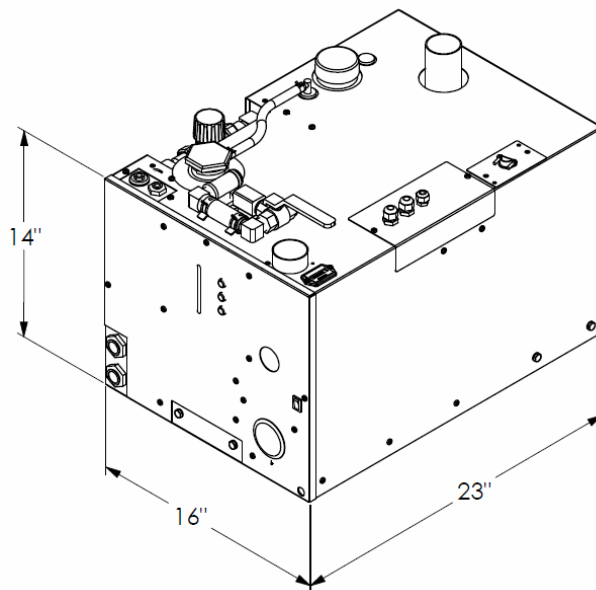

Figure 2-1: Hurricane®II Combi Heating System Dimensions

! DANGER

Hurricane®II Combi Heating System must not be installed or operated in any compartment with flammable gases.

! WARNING

If the Hurricane®II Combi Heating System is going to be mounted in the engine compartment, check for adequate ventilation. When the engine is running this area could be under a negative pressure. Make sure the air-intake and exhaust hoses have no leaks and are well fastened to the heater, muffler and thru-hull fitting. Assembly parts that may cause injury through accidental contact should be protected.

! DANGER

Isolate the unit in a closed compartment so that no air from the heater will infiltrate the living areas.

- It is recommended that a catchpan be placed under the Hurricane®II Combi Heating System for containing any unexpected leakage.
- Choose a sturdy surface in a location that won't be unduly affected by vibration and the jarring of rough roads.
- Ensure that the exhaust tubing can be properly and safely routed. The maximum exhaust run for the system is 12'.



2.3 What NOT to Do

- **Don't** mount the Hurricane®II Combi Heating unit directly underneath the sleeping area. The sound of the Hurricane®II Combi Heating System cycling on and off may disturb light sleepers.



2.4 Procedure

After choosing the mounting location for the Hurricane®II Combi Heating System, mount the system horizontally and level. Secure the Hurricane®II Combi Heating System in place (against the wall, floor or a mounting platform) using three (3) x 1/4" through bolts with 1" diameter fender washers, lock washers, and nuts or 1/4" screws. (See Figure 2-2: Module Mounting Brackets.).

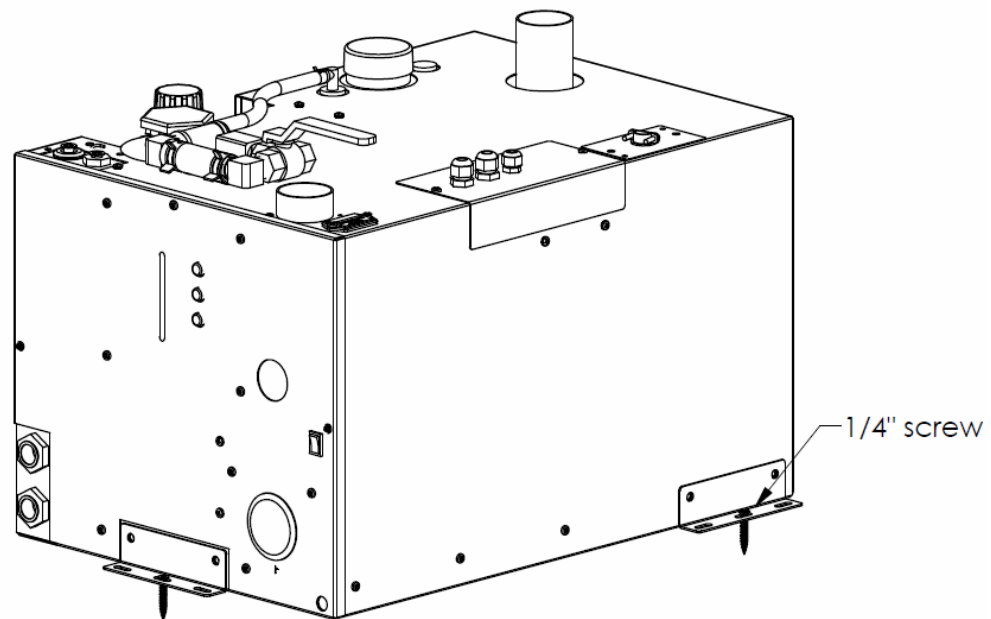

Figure 2-2: Hurricane®II Combi Mounting Brackets

Installing the Exhaust System



3.1 Before You Begin

For efficient and safe operation of the Hurricane®II Combi Heating System follow all recommendations for properly installing the exhaust. Any deviations from these must be approved in advance by ITR.

! DANGER

Although the heater's exhaust produces very low carbon monoxide emissions, caution is still advised:

- Do not operate the Hurricane®II Combi Heating System in an enclosed area unless there is adequate ventilation.
- Isolate the Hurricane®II Combi Heating System in a closed compartment so that no air from the unit will infiltrate the living areas.

Never place any exhaust parts close to combustible material or through a combustible wall or ceiling without fireproof protection. The exhaust can reach high temperatures. The products of combustion shall be ducted to the outside of the yacht.

3.2 Mounting Location

If you can't meet the technical specifications for mounting the exhaust, don't use the Hurricane®II Combi Heating System. The unit may perform poorly or become damaged if not installed according to specifications.



Recommended Exhaust Outlet Locations

- The exhaust of the heater must always exit **outside** the yacht, not inside the heater compartment. Otherwise, exhaust fumes could infiltrate the yacht from the Hurricane®II Combi Heating System.

Exhaust outlets shall:

- Be positioned so that wind turbulence will not affect proper operation
- Not be fitted within 12 inches (300 mm.) of a ventilator for the living area or an opening part of a window

In a yacht installation, the following is recommended for the exhaust outlet location:

- Make sure that the thru hull is at least 30" above the water line with a goose neck rise on the exhaust to prevent water from getting to the heater through the exhaust. If the dual exhaust air-intake thru hull is used, ensure that the air-intake is placed between 10 o'clock and 2 o'clock and also goose-necked to avoid water ingestion, see Figure 3-1.
- There needs to be a 1/8" air gap around the exhaust thru hull. Make sure that the holes for the mounting screws have enough material left to properly bite. The fitting must be centered in the hole.



Recommendation for Installation

- You may use sweep bends but each 90° 2" radius bend is equivalent to 1.5 feet of exhaust piping. The maximum recommended straight exhaust pipe length is 12' including one 90° bend. For additional bends, subtract 1.5 feet per bend. Do not exceed these recommendations.
- Combustion air must be drawn from outside the yacht.
- Use an ITR-manufactured muffler; no other muffler is acceptable.
- Exhaust outlet is on the top of the heater, towards the back.

! DANGER

The exhaust and outlet are HOT and the surrounding areas must be thermally shielded and protected from the hot surfaces and heat build-up by insulation. Nothing can come into inadvertent contact with any part of the exhaust system.

- Exhaust must have a minimum of 3" (7.6 cm) clearance from all surfaces.

Section 3, Installing the Exhaust System

- Ensure that the exhaust cannot be plugged or restricted.
- The exhaust fitting on the Hurricane®II Combi Heating System is 2" and the exhaust pipe used must have a minimum of 2.0" I.D. throughout its length.
- All exhaust elbows must be of a large radius design.
- The exhaust must be supported a minimum of every 3' of its installed length.
- The exhaust and Hurricane®II Combi Heating System connection point must use appropriate clamps and perhaps a small amount of sealing compound (do not overuse as it can clog the exhaust) to ensure that the connections are tight and leak free. The Hurricane®II Combi Heating System exhaust outlet pipe and the exhaust pipe itself must not be distorted or damaged during this process.
- When the Hurricane®II Combi Heating System is running the connection points and the system must be checked for leaks and any found must be corrected. Periodically, check the exhaust fittings, connections, exhaust tube, and insulation for leaks and integrity and correct if required.
- Appropriate exhaust insulation must be used to cover the entire length of any interior exhaust run.
- Solid stainless steel exhaust tubing or approved exhaust tubing is recommended but an approved stainless steel flexible exhaust tubing can also be used. If flexible exhaust tubing is used, the exhaust tubing must be inspected regularly for leaks and deterioration as this type of exhaust does not have the life expectancy of solid tubing. Stepped band clamps are recommended for joining flex and solid tubing as they apply firm, even pressure. See *Figure 3-1: Installing the Exhaust system*.



What NOT to Do

Don't use more than 8' of exhaust pipe if 180° of total bends are present.

Don't use any mufflers with flow restrictions. Use only ITR supplied or approved mufflers.

Don't over apply muffler cement and silicone so it blocks or reduces the exhaust outlet.

Don't over-tighten exhaust clamps or you may crush the Hurricane®II Combi Heating System's exhaust outlet pipe.



3.3 Procedure

Figure 3-1: Installing the Exhaust System shows a standard setup for the exhaust. To install the exhaust system:

- 1** Leave suitable air spacing to protect combustible materials; use an exhaust collar and metal shields where required.
- 2** Find an appropriate location for the exhaust hole of the heater.
- 3** Securely seal the exhaust piping to the heater fitting using an approved exhaust clamp. If exhaust cement is used, care must be taken to ensure no cement enters the interior of the exhaust pipe or heater fitting, otherwise the exhaust flow will be impeded and the heater operation compromised.
- 4** Connect the exhaust piping in series with the muffler, using heavy-duty exhaust clamps. If you use vibration isolation mounts they must be high temperature.
- 5** Connect the air intake tubing (2" ID) to the air intake fitting on top of the heater, and to an outside air intake fitting or dual thru hull (outside air only). Ensure the run of tubing is as short as possible to facilitate air flow.
- 6** Secure both ends of the air intake tubing with properly sized hose clamps to prevent air leaks.
- 7** Make sure the air intake and exhaust hoses have no leaks and are not touching each other.
- 8** On a yacht, make sure the thru hull is at least 30" above the waterline and the exhaust must be goose-necked (see Figure 3-1).

Section 3, Installing the Exhaust System

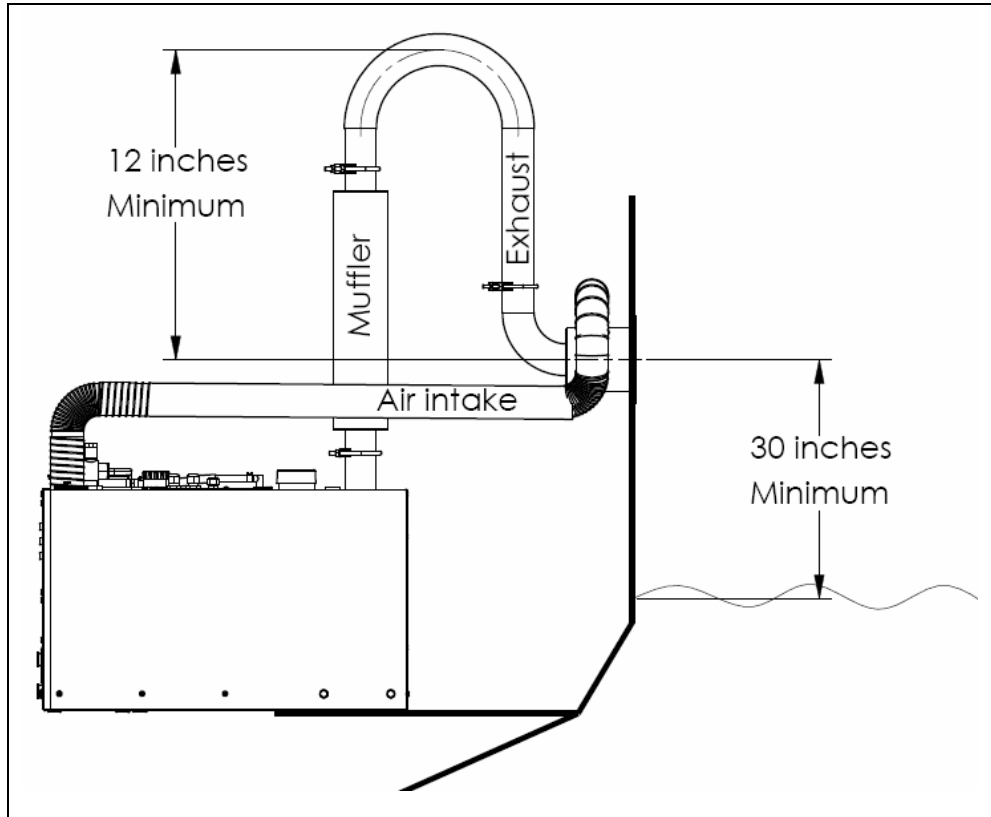
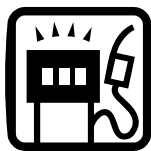

Figure 3-1: Installing the Exhaust System

Installing the Fuel System



4.1 Before You Begin

For efficient and safe operation of the Hurricane®II Combi Heating System, follow all recommendations for properly installing the fuel system. Any deviations from these must be approved in advance by ITR.

! DANGER

Never use gasoline in the heater. Use only diesel fuel, furnace oil or stove oil.

Keep fuel lines away from any heat source above 100°F (38°C).

Keep gasoline and any equipment that uses gasoline away from the Hurricane®II Combi Heating System location. The Hurricane®II Combi Heating System is not rated for use in an explosive environment.

! WARNING

Never share the fuel supply line to the Hurricane®II Combi Heating System with any other fuel-burning device.

4.2 Fuel System Installation

The fuel pump in the Hurricane®II Combi Heating System has a maximum flow capacity of 25 GAL/Hr and a maximum pressure of 11.5 psi. A 10 micron fuel filter is recommended. Select a fuel filter based on these requirements.



Recommendations for Installation

The Hurricane®II Combi Heating System's fuel connection is accessed from the top of the heater. The fuel inlet, is located on the top left of the Hurricane®II Combi Heating System and consists of a 1/8" NPT threaded female fitting. The fuel return, labelled, is located next to the fuel inlet and consists of a 1/8" NPT threaded female

fitting. Minimum recommended size for the fuel line is ¼" I.D. The fuel return line should return to the fuel supply tank.

The following is recommended for the fuel system installation:

NOTICE

The fuel supply from the fuel storage tank to the fuel inlet must be from a dedicated fuel pickup on the top of the tank.

- The fuel supply line should be installed with minimal rise from the fuel tank. The total rise from the bottom of the pickup tube to the fuel inlet on the Hurricane®II Combi Heating System should not exceed 60". There are no minimum clearance requirements between the fuel tank and the Hurricane®II Combi Heating System.

! CAUTION

The fuel line must be run and secured so as to prevent damage, chafing and kinking during normal operation.

- All fuel line connection points and hoses must use suitable clamps and/or sealant and must be checked for leaks on the initial installation and also periodically as part of normal maintenance.
- A primary, UL and/or CSA approved fuel oil filter (not provided) must be installed inline in the fuel supply hose, between the tank and the Hurricane®II Combi Heating System, in a manner that ensures easy access for maintenance. A secondary fuel filter is mounted inside the Hurricane®II Combi Heating System case. Both filters must be inspected and replaced as required as part of normal maintenance.
- Fuel line hose used must be appropriate for your requirements. It is strongly recommended that the hoses have permanently installed end fittings.



4.3 What NOT to Do

- **Don't** allow the fuel or the fuel lines to become contaminated with foreign material.
- **Don't** allow the fuel lines to become damaged or constricted.

! CAUTION

Ensure that fuel lines are always protected from contamination by foreign material. When installing or servicing, seal off ends to prevent contamination. After installing, you may also wish to flush the fuel line to rid of it air and any foreign material.



4.4 Procedure

To complete the fuel system installation:

- 1 Install the inline fuel filter. The optimal location is on a compartment wall next to the Hurricane®II Combi Heating System, inline between the fuel tank and the Hurricane®II Combi Heating System.
- 2 Connect the fuel line to the dedicated fitting on the main diesel fuel tank.
- 3 Inspect the supply fuel line for any loose connections or damage. Fittings must be airtight.
- 4 If desired, install a shut-off valve on the tank side of the fuel filter to allow shutdown and filter service.

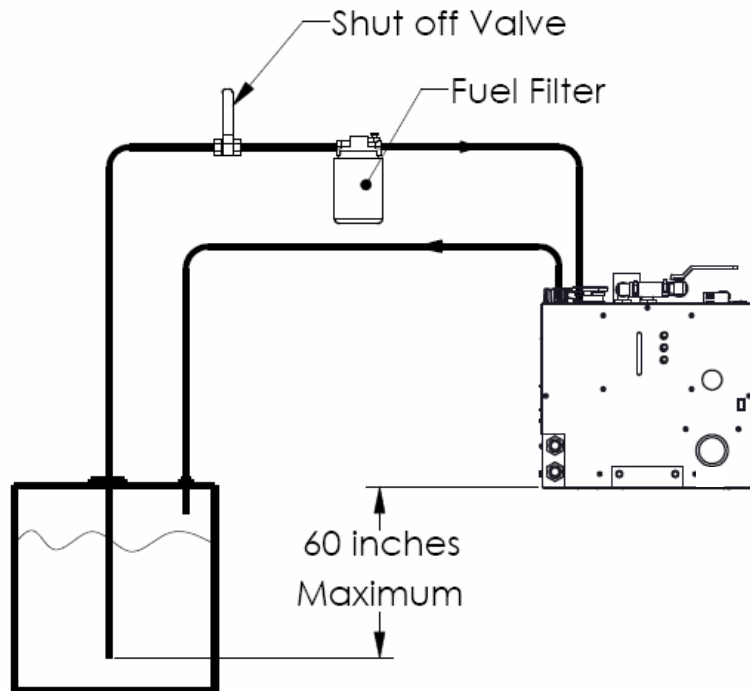

Figure 4-1: Fuel connection schematic

Installing Fan Heaters



5.1 Before You Begin

ITR makes the following fan heaters for individual cabins or areas:



Standard Cabin Fan (Part No. 6002)

- Dimensions: 10" Wide 6" High 6.75" Deep
- Power Requirement: 0.9 Amp @ 12VDC
- Output: 8,700 BTU/h @ 120F and 3.0 GPM
- Connections: 3/4" Hose
- Construction: Stainless Steel Case



High Output Cabin Fan (Part No. 6093)

- Dimensions: 10" Wide 6" High 6.75" Deep
- Power Requirement: 1.6 Amp @ 12VDC
- Output: 12,000 BTU/h @ 120F and 3.0 GPM
- Connections: 3/4" Hose
- Construction: Stainless Steel Case



Small Case Defroster Fan (Part No. 6048)

- Dimensions: 10" Wide 6.0" High 9.5" Deep
- Power Requirement: 10.5 Amp @ 12VDC on High
- Output: 16,000 BTU/h @ 120F and 3.0 GPM on High
- Connections: 3/4" Hose
- Construction: Stainless Steel Case



Low Profile Galvanized Cabin Fan (Part No. 6094)

- Dimensions: 13.25" Wide 4.5" High 8" Deep
- Power Requirement: 1 Amp @ 12VDC
- Output: 6,000 BTU/h @ 120F and 3.0 GPM
- Connections: 3/4" Hose
- Construction: Galvanized Case



Small Space Galvanized Cabin Fan (Part No. 6095)

- Dimensions: 9.0" Wide 5.5" High 5.0" Deep
- Power Requirement: 0.5 Amp @ 12VDC
- Output: 4,000 BTU/h @ 120F and 3.0 GPM
- Connections: 3/4" Hose
- Construction: Galvanized Case

Low Profile Dual Fan Defrost Heater (Part No. 6096)

- Dimensions: 15.5" Wide 6.0" High 13.0" Deep
- Power Requirement: 9.8 Amp @ 12VDC on High
- Output: 20,000 BTU/h @ 120F and 3.0 GPM on High
- Connections: 3/4" Hose
- Construction: Plastic Case

Note: A limited number of fan heaters can be used with the Hurricane®II Combi Heating System.

NOTICE

Only the installation of ITR fan heaters is covered in this Manual.

If you are installing non-ITR fan heaters, you must obtain prior approval from ITR. You must check the fans' total amperage draw to ensure they will be compatible with the Zone Control Board, as well as flow capacity to ensure that each fan meets system requirements.

5.2 Fan System Operation

ITR fans consist of a 12 VDC brushless fan and heater coil similar to a radiator.

When the heater unit comes on, the fan draws ambient air from the interior, blows it through the heater coil and back into the interior through a vent. There must be an input and output vent for each fan unit.

Features

- ITR heater fans can be supplied with a built-in aquastat, which prevents fan operation until the system has reached minimum operating temperature. Note that the Hurricane®II Combi Heating System has

a built-in heat detection aquastat that will only allow the circulation of coolant if the coolant inside the tank has reached a certain temperature. The installation of the aquastats on the fans are only necessary to prevent cold air from being blown out of the cabin fans during the brief period that it takes the coolant to travel from the tank to the cabin fans. *Figure 5-1* shows how to wire up the aquastat in a fan.

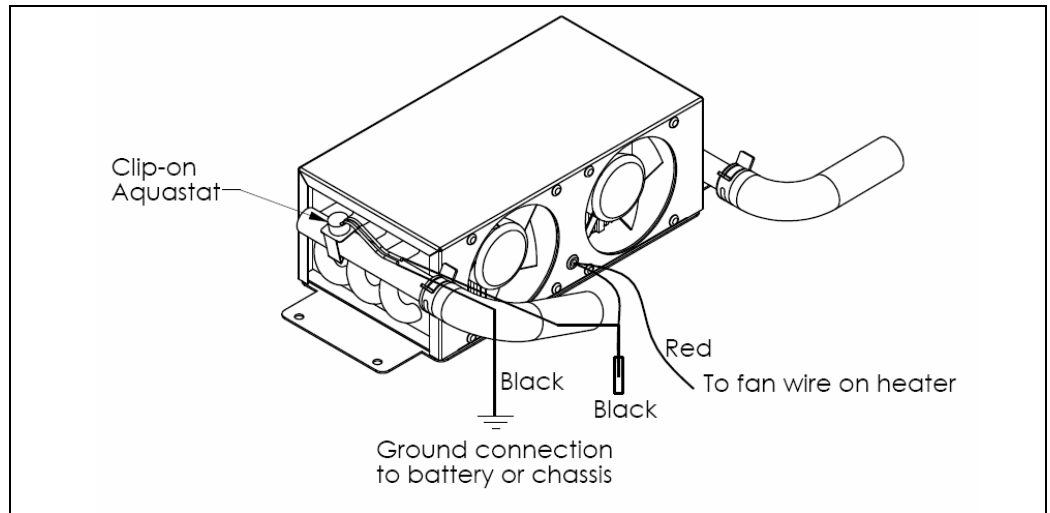

Figure 5-1: Wiring the Fan's Aquastat

- If a "passive" radiant heat system is desired (i.e. baseboard or fin and tube configurations), consult ITR for recommended installation procedures and design.

Multiple Zone Heating

The Hurricane®II Combi Heating System can supply heat up to three interior zones. Note that on the internal zone board, two zones are capable of handling a load of 10 amps each and the third zone can handle a load of 5 amps. Refer to *Section 6 – Electrical System*, and *Section 7 – Plumbing* for information on how to setup these zones.

Up to three thermostats (positive DC compatible) can be installed to allow temperature regulation of the zones. The thermostat controls the fan heater.

For larger installations, consult ITR.

Accessories and Components Needed

In addition to the fans themselves, you will need at least some of the following optional accessories and equipment which are not supplied but which can be purchased separately.

- **Thermostats** — thermostats can be installed in the interior.
- **Air Outlet Vents** — covers that are installed flush with the wall to vent heat for the installed heater unit.
- **Fan Guards** — to protect the fan blades from damage, recommended for fans installed in storage areas or other accessible areas where something could contact the fans.
- **Screws** — #10 sheet metal screws or wood screws to mount the fan units. See *Figure 5-2: Mounting a Spacesaver Fan*.
- **Two-Speed Fan Switches** — to enable low and high-speed settings from inside the yacht; for use with the variety of ITR Cabin heaters.
- **Three-Speed Fan Switches** — to enable low, medium and high-speed settings from inside the yacht; for use with the ITR defrost heater.
- **Air Ducting** — to allow you to install fans in a remote location (i.e. not directly adjacent to the interior space to be heated) and duct the heated air to its output location. Also, **air outlet plates** to allow you to install ducting for one, two or three separate outlets (e.g. you can use one fan to heat two different areas by installing a dual air outlet plate).



5.3 What NOT to Do

- **Don't** install more fans that require more heat than the Hurricane®II Combi Heating System can produce. Your system will not run effectively.
- **Don't** mount the return air outlet too close to the fan's air intake source.



5.4 Mounting Locations

Carefully choose the mounting locations of your fans:

ITR can suggest optimal fan locations if you provide a floor plan of your yacht.

- Locate the fans to evenly heat the zone.
- Provision must be made to protect water lines from freezing.
- Install fan at floor level or very near floor level, in order to optimize circulation.
- Allow a minimum 16 square inch (100 cm sq.) opening in the fan heaters' mounting compartment to allow sufficient intake of air.

ITR's cabin heaters come with loose or built in mounting brackets. The fans can be mounted on the floor or on the wall, either flat or on its side.

The thermostat should not be mounted on walls outside of the zone because that could cause false temperature readings. Mount on interior walls and bulkheads, away from windows, heater vents and cabin fan heaters.



5.5 Procedure

After choosing the appropriate mounting location and configuration:

- 1** Mount the fan using #10 sheet metal screws or wood screws, see *Figure 5-2: Mounting a Spacesaver Fan*.
- 2** If you are using ducting and a dual air outlet plate for any fan, limit the total length of duct for both outlets to 36" for optimum air output.
- 3** Select the appropriate mounting location for the thermostat, as well as any fan speed switches. You will wire these up to the Hurricane®II Combi Heating System in *Section 6 – Electrical System*.

- 4 The zone control board can control up to 3 zones. The cabin fan 1 lead (orange) and cabin fan 2 lead (gray) can supply up to a maximum of 10 Amps each. Cabin fan 3 lead (brown) can supply up to a maximum of 5 Amps. The total current draw is not to exceed 20 Amps for all cabin fan leads.
- 5 If the system requires higher amperage draws, install a separate relay to power the fans. This relay will use the existing fan circuit as a signal and must be wired to a secondary power source (fused from the battery + 've). See *Figure 5-3: Installing a Relay for Additional Fan Amperage*.
- 6 To install plumbing lines to the fans, see *Section 7 Plumbing the System*.

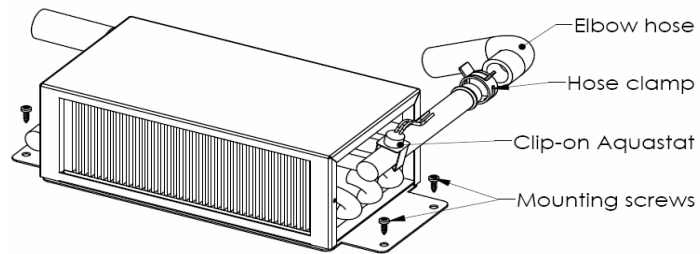

Figure 5-2: Mounting a Spacesaver Fan

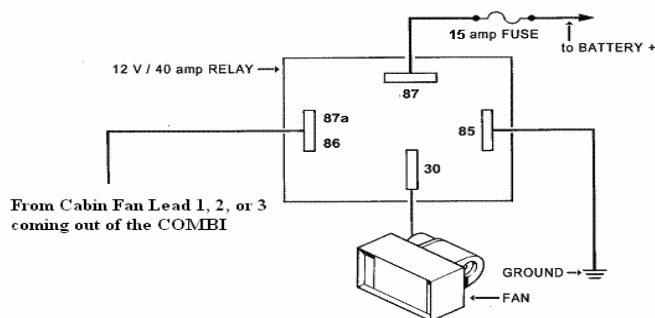

Figure 5-3: Installing a Relay for Additional Fan Amperage

Wiring the Electrical System



6.1 Before You Begin

The Hurricane®II Combi Heating System and its electrical Control Board are pre-wired and have been thoroughly tested together as a unit.

To review the wiring system for the Hurricane®II Combi Heating System, refer to the wiring diagram at the end of this *Section 6, Figure 6-1: System Wiring*.

! WARNING

All electrical connections and wiring must comply with normally-accepted 12 VDC and 120 VAC wiring practices, local regulations, and ABYC standards. Only a qualified electrical installer should complete the wiring. All field wiring is to be in accordance with CSA Standard C22.1, Canadian Electrical Code Part I or the National Electrical Code, ANSI/NFPA 70.

6.2 12 VDC

The following apply to the 12 VDC connections for the Hurricane®II Combi Heating System:

- There are three 12 VDC electrical connections on the top right of the Hurricane®II Combi Heating System. They consist of the primary DC positive (red), Zone DC positive (red), and negative (black) connection and are 14 gauge stranded copper wires.

! WARNING

Primary DC power should originate from a dedicated connection on the house battery bank. The Zone DC power can originate from a master disconnect switch. The Primary DC power and the Zone DC power must be separately fused. A fuse or breaker (20 amps for Primary DC; 25 amps for Zone DC power) must be included close to and inline from the battery to each of the Primary DC power and Zone DC power connections (both red and labelled) on the Hurricane®II Combi Heating System. The primary power wire

gauge must be sized to permit no more than a 3% voltage drop from the battery to the Hurricane®II Combi Heating System.

- A properly-shielded power system is required for safe, trouble-free operation.

6.3 120 VAC

- The Hurricane®II Combi Heating System is equipped with one 1500 watt, 120 VAC immersion element (240 VAC is also available). The connection for the electrical supply is located at the top right of the Hurricane®II Combi Heating System, under a cover, labeled AC Power.
- The power wires for the AC immersion element are three 14 gauge stranded copper leads that use standard AC color code (black-hot, white-neutral, green-ground). These are to be connected using standard 120 VAC electrical connectors and terminals.

NOTICE

Do not operate the electric immersion element until water is added to the Hurricane®II Combi Heating System, and all trapped air has been removed.

6.4 Remote Operating Panel Cable

- One connection on top of the Hurricane®II Combi Heating System is a multi-wire, sheathed cable with a 9 pin connector. This connects to a matching connector on a short adapter cable. The other side of the cable has a 10 pin connector that connects to a 25' remote cord (a 50 foot cord is also available). This remote cord then plugs directly into the Remote Operating Panel. Refer to *Figure 6-1: System Wiring*.

6.5 Zone Connections

Cabin Fan leads

- The positive (red) lead from each cabin fan is to be attached to one of the trailing cabin fan leads, color coded for zones, on the Hurricane®II Combi Heating System (see Figure 6-1).

- The negative lead from each cabin fan is to be attached to a ground terminal (not provided) that is connected to a battery ground.
- The cabin fan 1 lead (orange) and cabin fan 2 lead (gray) can supply up to a maximum of 10 Amps each. The cabin fan 3 lead can supply up to a maximum of 5 Amps. The total current draw is not to exceed 20 Amps for all cabin fan leads.
- If the system requires higher amperage draws, install a separate relay to power the fans. This relay will use the existing fan circuit as a signal and must be wired to a secondary power source (fused from the battery + 've). See Figure 5-3.

Thermostat Leads

- The power lead to the thermostat is to be attached to a 12VDC power terminal (not provided) that is connected to the battery.
- The return lead from each thermostat is to be attached to one of the trailing thermostat leads, color coded for zones, on the Hurricane® II Combi Heating System (see Figure 6-1).

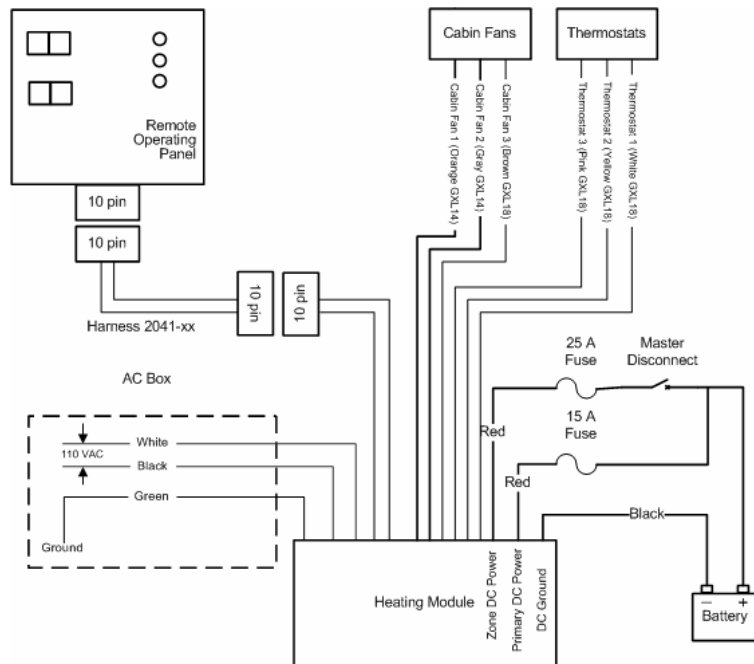

Figure 6-1 System wiring

6.6 Main Electronic Control Board

NOTICE

The main electronic Control Board is mounted onboard the Hurricane®II Combi Heating System itself. It has no user adjustable components.



6.7 What NOT to Do

NOTICE

Never shut off the Hurricane®II Combi Heating System primary DC power via an inline battery or master switch while the system is running. Never disconnect the battery when the Hurricane®II Combi Heating System is running, and never disconnect the battery while the inverter is charging. Do not wire the primary DC power of the Hurricane®II Combi Heating System through a disconnect that is used as a normal shut-down of the DC system.

Doing either will severely damage the Hurricane®II Combi Heating System because it fails to automatically purge the combustion chamber. Such damage is detectable upon inspection and will *not* be covered under warranty. Always shut the system off using the normal system controls.

Plumbing the System

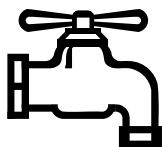

7.1 Before You Begin

For efficient and safe operation of the Hurricane®II Combi Heating System, follow all recommendations for properly installing the plumbing system. Any deviations from these must be approved in advance by ITR.

! DANGER

The Hurricane®II Combi Heating System must use only a non-toxic boiler anti-freeze, propylene glycol based coolant with additives generally recognized as safe "GRAS" by the FDA.

When heat is called for, the water pump inside the Combi sends heated fluid out to the cabin fans.

For efficient Hurricane®II Combi Heating System operation, you must:

- Minimize heat loss from the Combi Heating System and hoses.
- Follow the flow directions for the fluids in the Combi Heating System (*Figure 7-1*)

7.2 Plumbing Installation

The plumbing installation should consider the following:

- The Hurricane®II Combi Heating System has a filler neck located on the top of the unit and is equipped with a seven (7) pound radiator cap. The Combi has a built in two (2) quart overflow bottle attached to the filler neck.
- The return and supply coolant plumbing connections are on the top of the Hurricane®II Combi Heating System and are 1/2" male NPT fittings. The return coolant input to the Hurricane®II

Combi Heating System is a connection labeled “Inlet” and the supply coolant output from the Hurricane®II Combi Heating System is a connection labeled “Outlet”. Ensure proper direction of flow. Refer to Figure 7-1: Hurricane®II *Combi Heating System* for the location of the fittings.

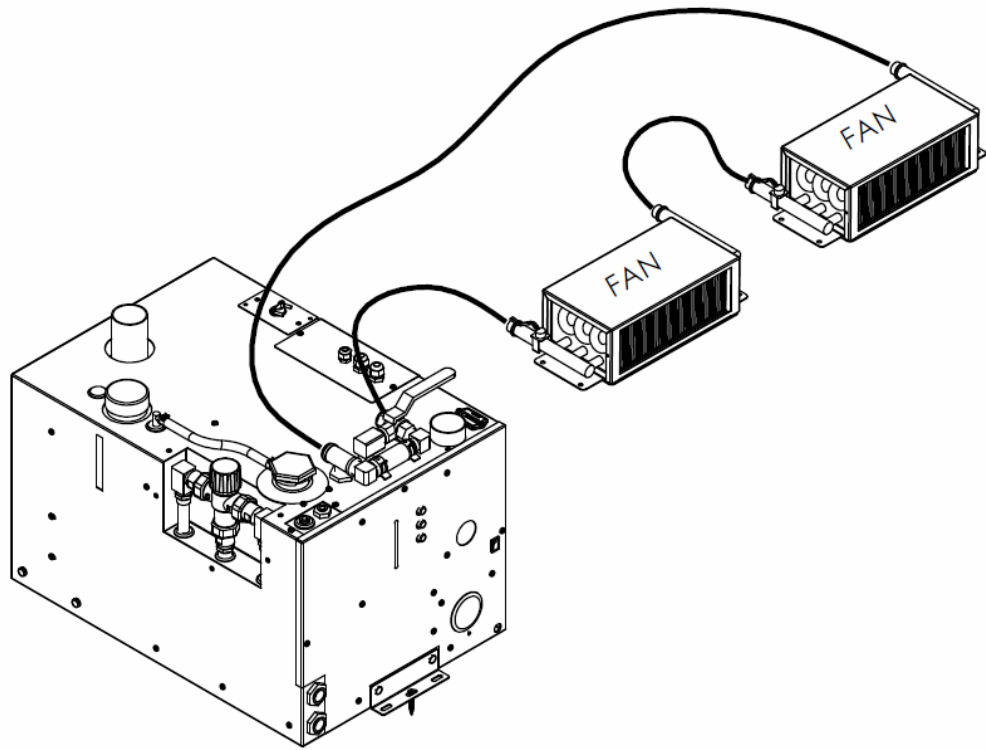

Figure 7-1 Hurricane®II Combi Heating System and cabin fans

- Two 1/2" NPT pipe to 3/4" hose barb fittings (not supplied) must be fitted into the Hurricane®II Combi Heating System connections and tightened to a leak free condition using an appropriate thread sealant.
- Hose and/or tubing used to connect to the Hurricane®II Combi Heating System inlet and outlet connections must be heavy duty heater hose, minimum 3/4" I.D, or 5/8" PEX. There are three approved methods of installing heater hose or PEX tubing (see Figure 7-2. Consult ITR for alternative methods and products.

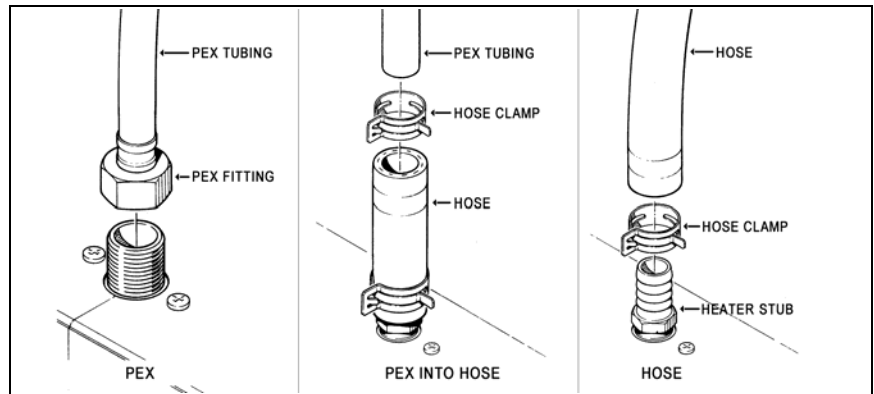

Figure 7-2: Three Approved Methods of Installing Heater Hose

- Plumb the cabin fans in a series loop as shown in Figure 7-1.

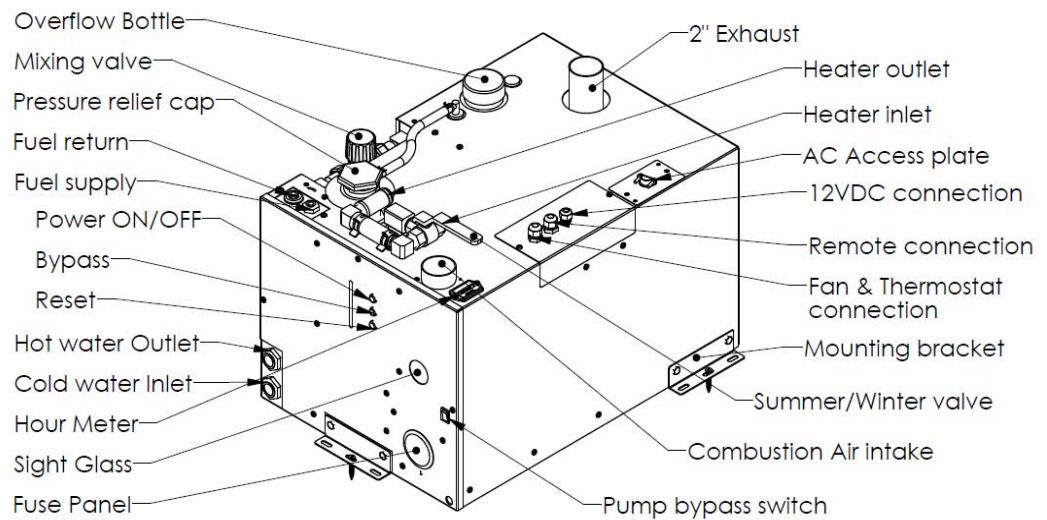

Figure 7-3 Hurricane®II Combi Heating System

NOTICE

All fittings on the Hurricane®II Combi Heating System require two wrenches when tightening. One wrench must be placed on the fitting and held in place to prevent this fitting from being overstressed. The other wrench can be used to tighten the matching half of the fitting onto it. Failure to follow this procedure will damage the Hurricane®II Combi Heating System and the fittings.

! DANGER

Do not operate the Hurricane®II Combi Heating System until a proper water/anti-freeze solution has been added to the Hurricane®II Combi Heating System and all trapped air has been bled. An inadequate mixture may cause system circulation problems and potential Hurricane®II Combi Heating System damage and/or personal injury. Use only a non-toxic, propylene glycol based coolant with additives recognized as safe "GRAS" by the FDA. Refer to the anti-freeze manufacturer recommendations for instructions for your application.

- The Domestic water connections are located on bottom of the front panel. The cold water supply and the hot water out connections can be made using ½" NPT fittings. The maximum water supply pressure to the system is 100 PSI (7 bar). The Hot water Outlet temperature is regulated by a mixing valve factory set at 120F (49°C). If needed this valve can be adjusted in a range from 100F (38°C) to a maximum of 145F (63°C). For more details about adjusting the temperature see section 7.4. For winterization, the domestic water lines should be flushed with non-toxic antifreeze. This will prevent damage to the internal heat exchanger due to freezing water. See *Figure 7-4: Domestic Hot water system plumbing*.

WARNING

All fittings, hose, tube and fitting sealant involving the domestic water must be food safe and approved for use with domestic water and rated for the domestic water system pressure.

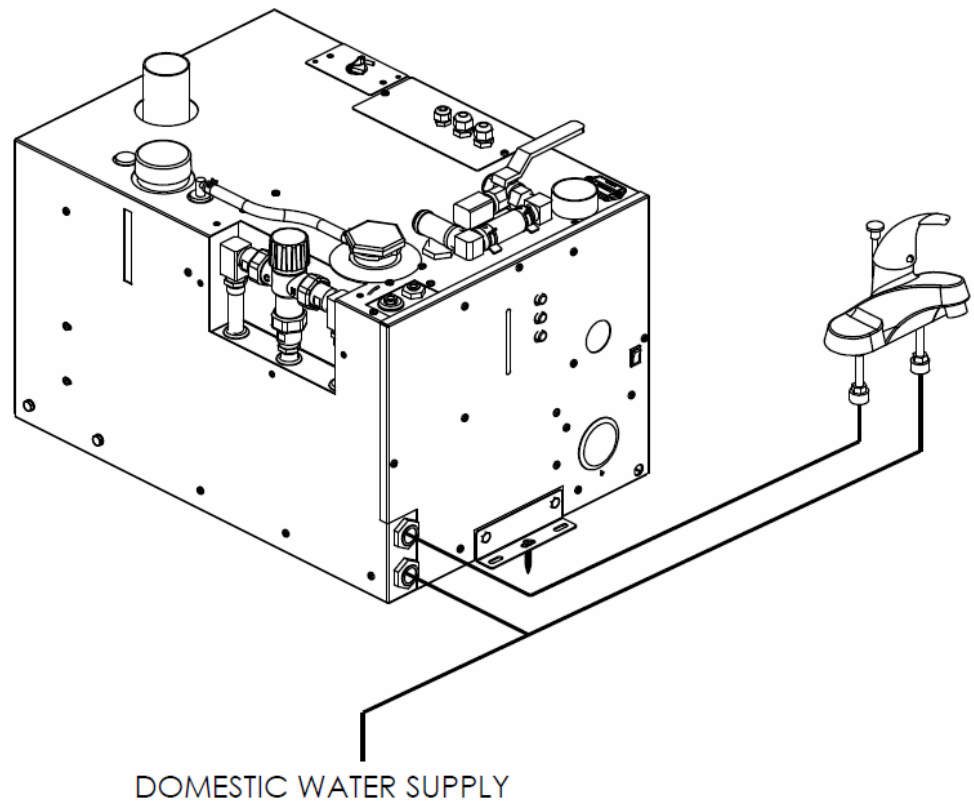

Figure 7-4 Domestic Hot Water System Plumbing

NOTICE

All fittings, hose and/or tubing involving the domestic water component of the Hurricane®II Combi Heating System, must be approved for use with domestic water and rated for the domestic water system pressure

- All plumbing lines must be run and secured so as to prevent damage, chafing and kinking
- Ensure that the coolant flow is adequate through the Hurricane®II Combi Heating System. An indication of inadequate flow is, when the Hurricane®II Combi Heating System is running and up to normal operating temperature, the difference between the inlet and outlet coolant temperature to the Hurricane®II Combi Heating System is more than 20F.
- The Hurricane®II Combi Heating System should be filled and flushed prior to operation to remove any foreign debris.

- Use heavy-duty heater hose or PEX tubing. Slip-on foam insulation coverings may be used over the hose fittings to reduce heat loss. Secure all hose connections with spring clamps.
- Air vents for the fluid circulation system are not supplied, but may be optionally installed to help bleed air from the system.

Heat exchangers can be installed for engine waste heat, and preheat functions. You will need one heat exchanger per engine.

7.3 Engine Waste Heat Function

Besides space and domestic water heating, your HURRICANE® II Combi Heating System heater can be used to both preheat your engine and to recycle waste heat produced by the engine.

A coolant cooled engine produces a large amount of waste heat while running. You can use this waste heat, to help heat your boat by adding an inline heat exchanger(s) to your heating system as shown in Fig. 7-5. Plumbing the engine heat exchanger(s) on the return side of the heating loop will distribute waste engine heat to the entire boat and supplement the diesel burner. The engine waste heat can only be used when the Combi is turned ON and in Winter loop.



NOTICE

It is not recommended to mix your engine cooling system with your heating system. Before connecting anything to your engine, consult your engine owner's manual for any restrictions or plumbing into the engine cooling system.

7.4 Engine Pre-Heat Function

As an option, the heat exchanger can also be used to pre-heat an engine before starting it. Set the Combi to Winter loop. Turn on the heater by the manual remote switch and turn up a thermostat. If the heat exchanger is mounted upright, close to and near the bottom of the engine, it will transfer heat to the engine's cooling system through gravity circulation. A more positive solution is to install a pump on the engine side of the heat exchanger wired to an external power supply in series with an engine preheat switch.

Pre-heating the engine makes it easier to start and it can be put under load immediately.

If installed, the engine pre-heat function is enabled by flipping a separate manual switch mounted inside the living area (not supplied), while the engine is **off**. This turns on the secondary engine pre-heat pump.

Procedure



To set up the engine pre-heat function:

- 1** Mount a manual switch in an appropriate place in the interior, usually near the dashboard.
- 2** Wire the manual switch to the engine water pump by connecting it to the main feed on the control board that connects to the yacht's power source (beside the battery connection). The switch circuit should include a 5 amp fuse on the power side.
- 3** Connect the ground-wire of the engine water pump to battery negative.
- 4** To test the engine pre-heat function, turn on the heater and allow it to come to temperature (about 10 minutes). Turn on the manual switch to start the engine pre-heat pump. Start the yacht engine, which should now be pre-heated to about 40°F (5°C) above ambient temperature.

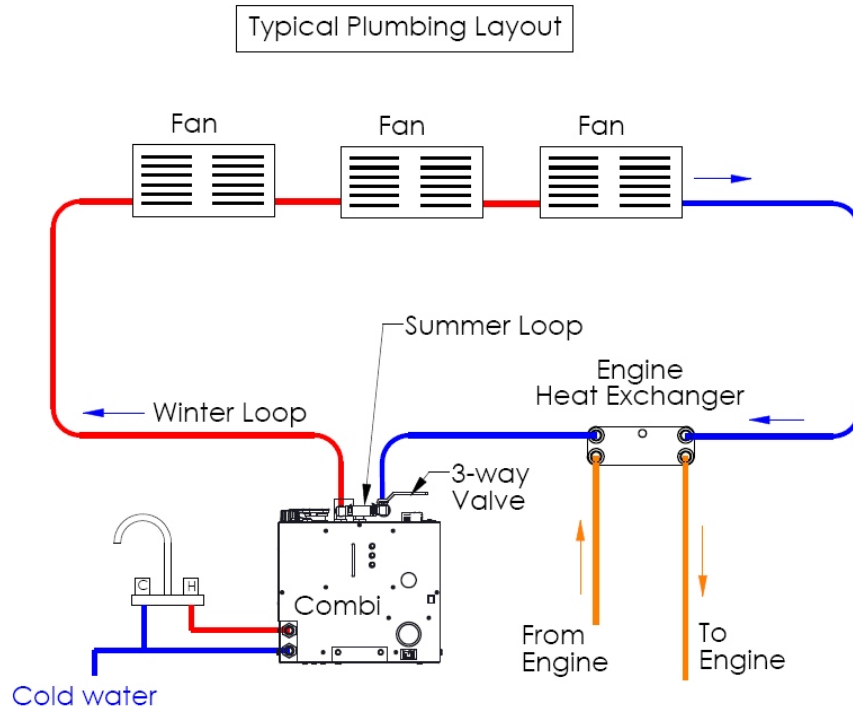

Figure 7-5 Engine Heat Exchanger/System Plumbing



NOTICE

7.5 What NOT to Do

The Hurricane® II Combi Heating System's circulating water pump is one of the most critical parts of the system. **Never** let the pump run dry or you will damage the impeller. This is not covered under warranty.

Don't use low-quality heater hose.

Don't let the hose come into contact with solvents, which may cause it to soften and swell. If there is any risk that solvents may contact the hose, insert it into PVC plastic tubing for protection.

7.6 Filling/Purging the heating system

To initially fill up and bleed the air out of the system, do the following:

1. Remove the radiator cap from the filler neck on the Hurricane® II Combi Heating System.
2. Set the Summer/Winter valve to Summer Mode
3. Begin pouring a 50/50 mixture of propylene glycol and water into the filler neck until the coolant level comes up to the filler neck.

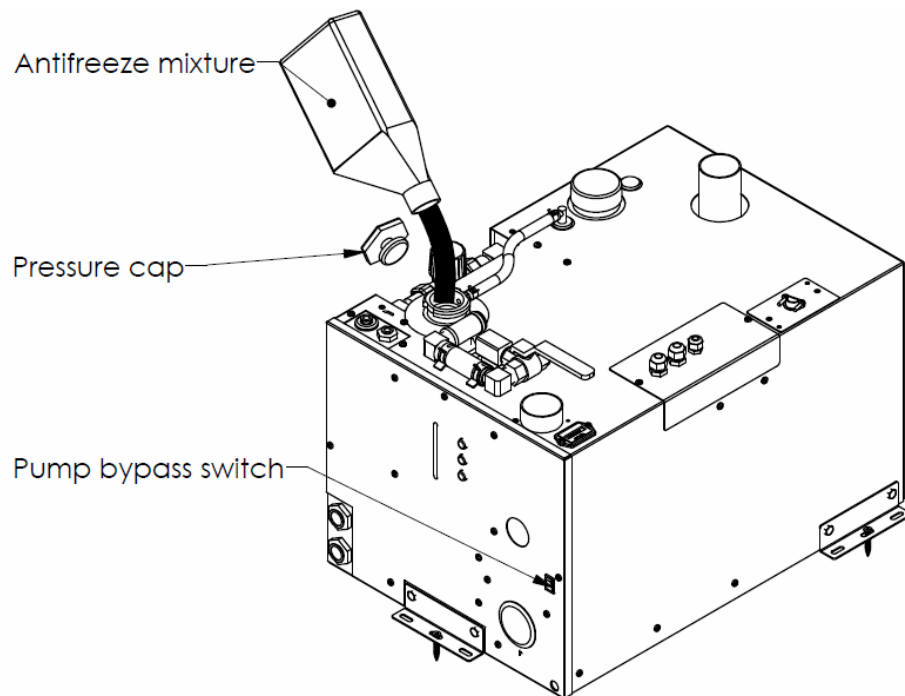

Figure 7-6: Initial fill up Hurricane® II Combi Heating System

4. Turn on the pump bypass switch on the front face of the Hurricane® II Combi Heating System and turn on a Thermostat. This will begin filling up the internal storage tank of the combi unit.
5. Once all the air is purged open the Summer/Winter valve to winter mode. This will allow the pump to distribute the coolant throughout the coach. Be careful as air is bubbling out of the tank and continue filling the system at the filler neck.
6. Allow the pump to run for 10 – 15 minutes or until all of the air has been purged from the system. Add coolant as necessary to bring the coolant level up to the filler neck.
7. Secure the radiator cap back in place and turn off the pump bypass switch.

8. Review the coolant level after a few hours of operation and refill and purge again as necessary as the air will escape in the system.
9. The Hurricane®II Combi Heating System is ready to be operated.

7.7 Hot water temperature adjustment

The Hurricane®II Combi Heating System has the option to adjust the temperature of the domestic hot water outlet. Standard this temperature is set at 120F (49°C). Turning the knob left (clockwise from top view) will increase the hot water outlet temperature up to a maximum of 145F (63°C). Turning the knob right (counter-clockwise) will decrease the hot water outlet temperature down to minimal 100F (38°C). The mixing valve adjustment knob is shown in the figure below.

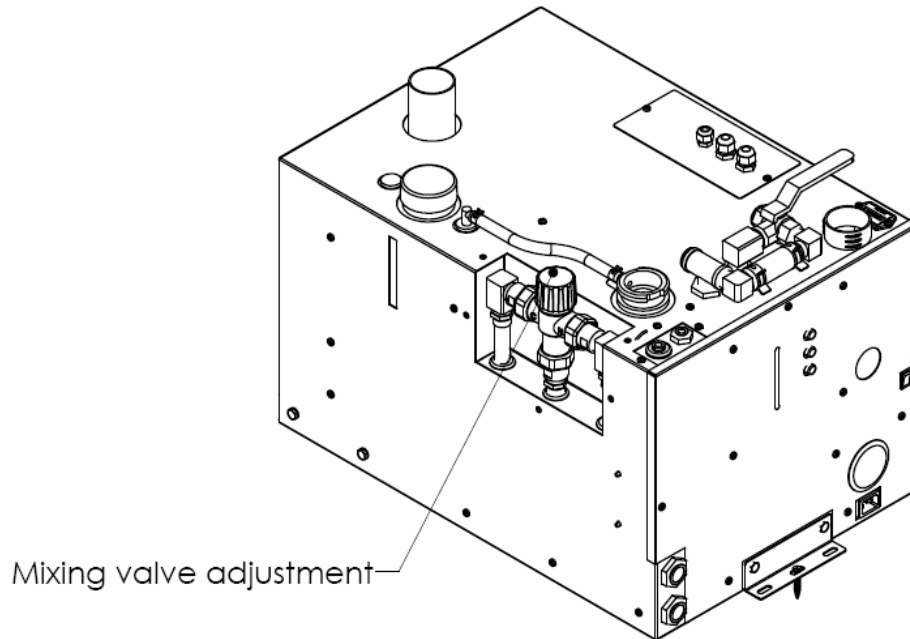

Figure 7-7: Mixing valve location

WARNING

The parts inside the module are **HOT** when in operation. Use gloves when adjusting the mixing valve.

Operating the Hurricane® II Combi Heating System

This section describes the operation and maintenance of your new Hurricane® II Combi Heating System. READ THESE INSTRUCTIONS AND SAVE FOR REFERENCE.

8.1 Operating Instructions for the Hurricane® II Combi Heating System

NOTICE

The Hurricane® II Combi Heating System must be installed in accordance with the recommendations in this Installation and Operating Manual prior to operating the heater.

- The Hurricane® II Combi Heating System, *Figure 8-1: Hurricane® II Combi Heating System* heats the coolant to a preset temperature and will automatically cycle to maintain the temperature.

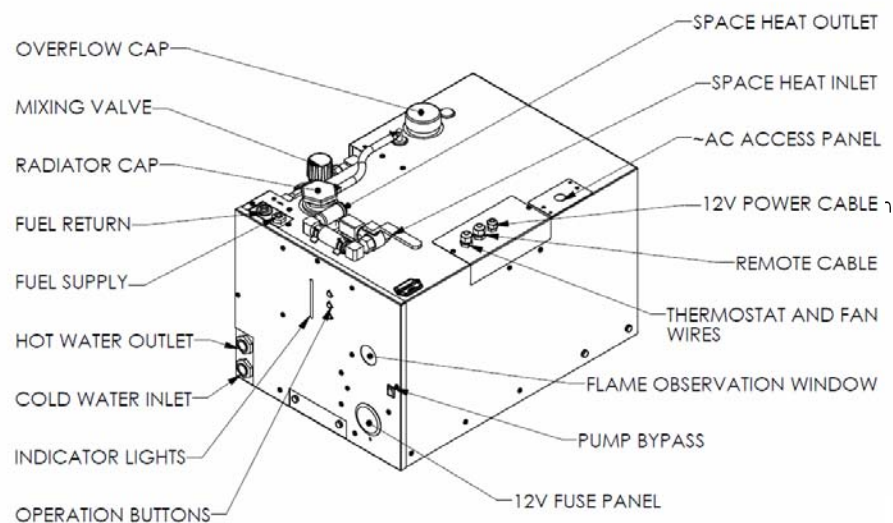

Figure 8-1 Hurricane® II Combi Heating System

8.2 Turning ON the Power to the Hurricane®II Combi Heating System

- The Hurricane®II Combi Heating System's main Control Panel, *Figure 8-2: Combi Heating System Main Control Panel*, located on the front of the module contains three push buttons: ON/OFF power, Bypass, and Reset. The power switch must be pushed ON (power LED will turn ON) to turn the DC electrical power to the main control board and module ON and is required to be left ON during any period where heat is requested.
- When the Hurricane®II Combi Heating System is shut down for any extended period or the season, it is recommended that the power switch be turned OFF.

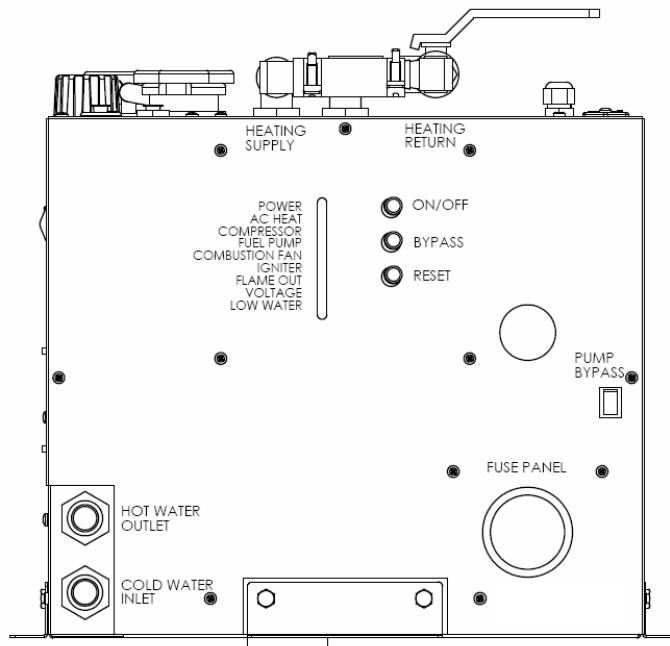

Figure 8-2 Combi Heating System Main Control Panel

NOTICE

Do not operate the Hurricane®II Combi Heating System until a suitable water/anti-freeze solution is in the heating system and all trapped air has been bled or removed.

! DANGER

Use only a non-toxic boiler anti-freeze, propylene glycol based coolant with additives generally recognized as safe "GRAS" by the FDA in the Hurricane®II Combi Heating System.

8.3 Activating the Burner (Primary) and Electric Heat (Secondary) from the Remote Operating Panel

Activating the Burner (Primary Heat Source)

- The burner switch on the Remote Operating Panel controls the ON/OFF of the diesel burner (primary heat source). When the burner switch is turned ON, the diesel portion of the Hurricane®II Combi Heating System will turn ON after ten seconds. The Burner LED will turn ON when the diesel burner has been activated. The burner will continue to operate until the coolant in the Hurricane®II Combi Heating System reaches the set operating temperature range. At this point, the diesel burner will turn OFF. If the Hurricane®II Combi Heating System coolant should cool down below this temperature range, the burner will again commence firing and will continue until either the burner switch on the remote panel is turned OFF or the temperature range is again achieved. If the burner switch on the remote panel is turned OFF, the burner stops and the Hurricane®II Combi Heating System enters a two minute cool down stage prior to completely shutting down.

Activating Electric Immersion Element (Secondary Heat Source)

- Turn ON the Electric switch on the Remote Operating Panel. The Electric (green) LED will turn ON indicating the electric element is energized and the coolant is being electrically heated. It will continue to operate until the coolant in the Hurricane®II Combi Heater reaches the set operating temperature range. At this point, the element will turn OFF. If the Hurricane®II Combi Heating System coolant should cool down below this temperature range, the electric element will again be energized and will continue until either the Electric switch on the remote panel is placed in the OFF position or the temperature range is again achieved. If the electric element switch on the remote panel is turned OFF, the electric element is de-energized and the Electric (green) LED turns OFF.

Activating the Burner and Electric immersion Element Jointly

- Turn ON the burner switch and the Electric switch on the Remote Operating Panel. The Burner and Electric (green) LED's will turn ON indicating the diesel burner and Electric element(s) have been selected.

8.4 Activating the Cabin Fan Heaters through the Thermostats

(Burner or Electric Heat ON)

- Any thermostat connected to the Hurricane®II Combi Heating System and calling for heat will cause the cabin fan controlled by that thermostat to be enabled. Once the room temperature has reached the temperature called for by the thermostat the cabin fan will turn off.

8.5 Activating the Domestic Hot Water

(Burner or Electric Heat On)

- As long as heat is available in the Hurricane®II Combi Heating System, it will respond to a call for domestic hot water. Ensure that a heat source has been selected (i.e. Burner or Electric). The production of the domestic hot water is **continuous** on the Burner operation and **limited** when using Electric.

NOTICE

The domestic water pump is not a part of, nor controlled by the Hurricane®II Combi Heating System.

8.6 Activating Summer or Winter Mode

- The Hurricane®II Combi has a manual summer winter valve. In summer mode the coolant will only circulate inside the heater and provide hot domestic water only. In the winter mode the coolant will also circulate through the space heating loop, providing space heat and hot water simultaneously. The summer/winter valve is located on top of the unit see Figure 8-3.

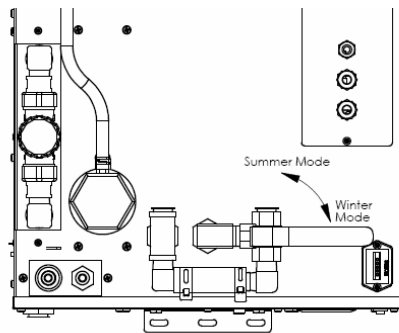

Figure 8-3 Location of the summer/winter valve

8.7 Remote Operating Panel Functions

- The Hurricane Combi Heating System's Remote Operating Panel, *Figure 8-4 Remote Operating Panel*, contains one ON/OFF burner switch, one ON/OFF Electric element switch, and three LED's indicating Burner activation, Electric element activation, and fault.

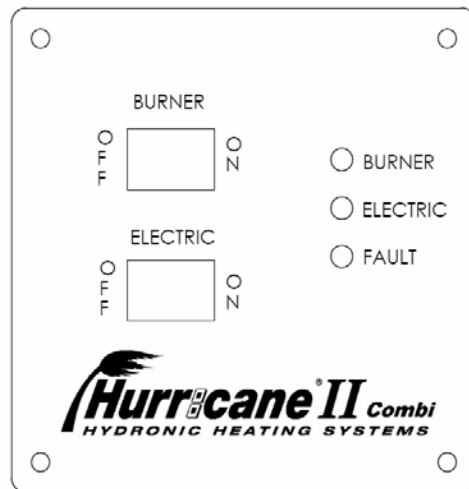

Figure 8-4 Remote Operating Panel

Burner Switch (Primary Heat Source)

- The burner switch on the remote panel controls the ON/OFF of the diesel burner. The Burner LED will turn on when the diesel burner has been activated.

Electric Element Switch (Secondary Heat Source)

- The electric element switch controls the ON/OFF of the 120 or 240 VAC immersion heating element. The electric LED will turn ON to indicate when the element has been activated.

Burner LED (Green)

- When ON, indicates the diesel burner has been activated.

Electric LED (Green)

- When ON, indicates if the 120 (or 240) VAC immersion element is activated.

Fault LED (Red)

- When ON, indicates the Hurricane®II Combi Heating System has faulted. The specific fault can be identified by examining the Hurricane®II Combi Heating System Control Panel located on the front of the Hurricane®II Combi Heating System. There are indicator LED's on the panel that are used for diagnostics. Refer to the description of the Hurricane®II Combi Heating System Control Panel for further details.

8.8 Functions of the Hurricane®II Combi's Control Panel

- The Hurricane®II Combi Heating System's Control Panel, Figure 8-2: Combi Heating System Main Control Panel, contains three push buttons: ON/OFF power, Bypass, and Reset. In addition, it contains nine LED's indicating Power, AC Heat, Compressor, Fuel Pump, Combustion Fan, Igniter, Flame Out, Voltage and Low Water.

Power Button

- The power button turns the power to the control board ON/OFF. The Power LED (green) turns ON when there is power to the control board.

Bypass Button

- The bypass button is for **authorized service personnel only**.

Reset Button

- The reset button when pressed resets the control board.

Power LED (Green)

- The power LED (green) turns ON when the power to the control board is ON. The LED flashes when the Hurricane®II Combi Heating System is in Bypass mode.

AC Heat LED (Green)

- The AC Heat LED (Green) turns ON when the AC immersion element has been activated.

Compressor, Fuel Pump, Combustion Fan, Igniter (Green)

- The compressor, fuel pump, combustion fan, and igniter LED's (Green) turn ON when the component is ON, and will flash if the component is electrically open or shorted.

Flame Out (Red)

- The Flame Out LED (Red) turns ON when a flame fault has been detected.

Voltage Fault (Red)

- The voltage fault LED (Red) turns ON when a voltage fault has been detected.

Low Water (Red)

- The Low Water LED (red) turns ON when a low coolant level in the Hurricane® II Combi Heating System has been detected.

8.9 Functions of the Zone Control Board

- The Zone Control Board, *Figure 8-5 Zone Control Board*, is responsible for controlling the flow of coolant throughout the Hurricane™ Combi Heating System, as well as the operation of the cabin fans. It has four user accessible fuses: one for the circulating pump, and three for the cabin fans.

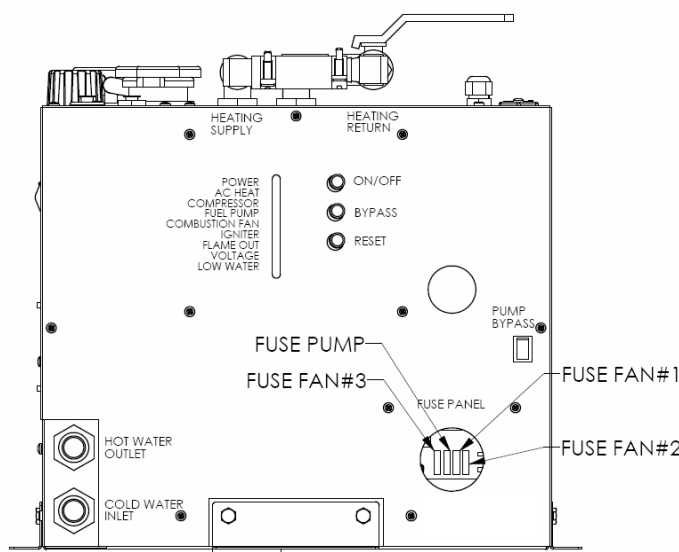

Figure 8-5: Zone Control Board

8.10 Maintenance

Customer Monthly Maintenance: Check the following and correct as required:

- Coolant hoses and fittings for leaks and integrity.
- Check coolant level in the overflow bottle (3/4 full when hot). **Fill only when the system is COLD and in small quantities only to prevent overfilling.**
- Exhaust fittings, connections, tubes for leaks, and integrity.
- Exhaust and air-intake checked for no obstructions.
- Fuel lines, fittings for leaks and integrity.
- External fuel filter for clogging.

Annual Service Requirements: Perform the following:

- **Prior to operation for the season, a factory service tune-up of the modular system should be performed by trained service personnel.** Only personnel familiar with the equipment modules should perform the service tune-up. It is recommended that the dealer be contacted for this service or if not available, contact ITR for information on service resources.
- As a general guide, the regular maintenance items such as the igniter, fuel filters (internal and external), and air filter (internal) should be replaced as opposed to inspected and cleaned. Their performance may be deteriorating and/or their remaining service life ending without any apparent visual signs or operating symptoms.
- The major components such as the air compressor, fuel pump, fuel nozzle, and combustion air fan should be examined for wear and should be replaced by the service technician as required.
- The combustion tube should be inspected by the service technician for wear and replaced if necessary. To access the combustion tube, the front panel of the Hurricane®II must be removed along with the burner box cover. The fuel block must then be removed from its mounting position. Finally, the burner and counter-flow tube must be taken out by removing the nuts holding the burner box in position. If the tube is satisfactory, a thorough cleaning of the tube and burner chamber should be performed by blowing out and vacuuming any ash and carbon

buildup. Any build up on the surface of the burner chamber will cause the heater to lose efficiency.

- Regular inspection and maintenance is the only way to ensure safe, reliable and efficient operation of your heating system.

8.11 Protecting the Hurricane®II Combi Heating System

NOTICE

Protect the Hurricane®II Combi Heating System from temperature extremes and any dusty, dirty, corrosive environment.

! DANGER

Protect the heating system from cold temperatures and corrosion by using a proper mixture of anti-freeze and water. Use only a non-toxic propylene glycol based coolant with additives generally recognized as safe "GRAS" by the FDA in the Hurricane®II Combi Heating System. Read and follow the anti-freeze manufacturer's instructions for the type of anti-freeze and mixture recommended for your application.

NOTICE

Note that any domestic water in the Hurricane®II Combi Heating System will freeze in cold temperatures and will damage the internal parts. The domestic water lines must be flushed with non-toxic antifreeze before freezing temperatures are encountered.

8.12 General Troubleshooting

Ensure that your Combi Heating System has both sufficient battery voltage and ground, and coolant level as the module is designed not to allow operation if either are incorrect (indicated by lit Voltage LED or Low Water LED on the Hurricane®II Combi Heating System Control Panel).

Burner Does Not Start Up

- Hurricane®II Combi Heating System connected to 12 VDC power?
- Power button on Hurricane®II Combi Heating System Control Panel pushed ON? Power LED lit on Hurricane®II Combi Heating System Control Panel?
- Burner switch on Remote Operating Panel ON? Burner LED lit on Remote Operating Panel?
- Main fuse or circuit breaker blown or tripped?

Electric immersion elements do not activate

- Module connected to 120 VAC power?
- Electric switch on Remote Operating Panel ON? Electric LED lit on Remote Operating Panel?
- Electric immersion elements circuit breakers tripped?

Burner Starts but Flame Faults

- Fuel supply present and adequate?
- Air-intake or exhaust not blocked or obstructed?
- Air in fuel line (white smoke from exhaust or popping sound from exhaust)?
- Fuel filter (external) dirty?

Burner Starts but no Space heating

- Thermostats turned ON?
- Fuses on Zone control board blown?



Warranty Information

Attention Purchaser and Installer

NOTICE

No warranty covers damage or failure of the heater, hot water heater, heating module, distribution module, or space heating module (collectively, "the Product") or to the vehicle in which it is installed, due to unapproved, unauthorized, or improper installations of the Product. Use of any unapproved materials or equipment in the Product's installation or operation will result in a voided warranty for the entire heating system.

- You must install the Product in compliance with the specifications, standards, and instructions in the *Installation Manual*.
- If you need to depart from the manual, you must first consult and obtain the written approval of ITR. Otherwise, your warranty may be voided or limited.
- Systems that are not installed to the published installation instructions (unless with prior written approval of ITR) will be ineligible for warranty coverage.
- Fill in the enclosed Warranty Card completely. It must be signed by the Owner and returned to ITR within 30 days of the date of the original installation. The Owner cannot transfer this warranty. Before mailing, make photocopies of the completed Warranty Card for your records. It will be a valuable reference if you need warranty repairs in the future.

General Warranty

ITR warrants all water jackets or coolant jackets in the Products to be free of defects in materials and workmanship under design usage and service conditions for three (3) years from the date of the sale to the original retail owner or three thousand (3000) hours of operation of the Product, whichever comes first.

ITR warrants the water tank in the Hot Water Heater to be free of defects in materials and workmanship under design usage and service conditions for two (2) years from the date of the sale to the original retail owner or two thousand (2000) hours of operation of the Product, whichever comes first. All other accessories and components supplied or installed in the heater will be covered by the lesser of the accessory and component manufacturer's warranty or a period of two (2) years or two thousand (2000) hours from the date of the sale to the original retail owner of the Product. Warranty replacement parts are covered for the remainder of the Product's warranty or ninety (90) days, whichever is greater. At ITR's discretion, coverage for warrantable parts may be made to the Owner in the form of repair, replacement, or credit.

Limited Warranty

The following warranties are in lieu of all other warranties and conditions. ITR makes no other warranties, representations, or conditions, express or implied. Expressly excluded are all implied or statutory warranties or conditions of merchantability of fitness for a particular purpose, and those arising by statute or otherwise in law or from dealing or trade usage.

The stated express warranties are in lieu of all liabilities or obligations for damages arising out of or in connection with the delivery, use, performance, or licensing of the Product or in connection with any services performed. In no event whatsoever will ITR be liable for indirect, consequential, exemplary, incidental, special, or similar damages, including but not limited to, lost profits, lost business revenue, failure to realize expected savings, other commercial or economic loss of any kind or any claim against ITR by any other party arising out of or in connection with the sale, delivery, use, performance, or repair of the Product, or in connection with any services performed, even if ITR has been advised of the possibility of such damages, whether based upon warranty, contract, or negligence. ITR's maximum liability shall not in any case exceed the contract price for the Products claimed to be defective.

No one is authorized to increase, alter, or enlarge ITR's responsibilities or obligations under these warranties.

Owner's Responsibilities

If any warrantable failures occur before the expiration of the warranty, the Owner must give notice of such failures to ITR or to the authorized ITR dealer from which the Product was originally purchased, and obtain written approval for the warranty repair.

The Owner is responsible for the following costs in case of a warrantable failure:

- shipping and insurance costs to deliver the defective Product to the dealer or ITR (if necessary)
- all repairs made to equipment ancillary to the Product, including the vehicle, yacht, engine, and other associated components of the vehicle or vessel in which the product is installed
- lodging, meals, and other incidental expenses incurred by the Owner as a result of a warrantable failure
- "down time" expenses and all business costs and losses resulting from the warrantable failure

Not Covered Under Warranty

Warranty will be voided or not extended in the following circumstances:

- Owner fails to notify ITR or the authorized ITR dealer from which the Product was originally purchased about a warrantable failure and to obtain prior written approval for warranty repair.

- Original serial number on Product or electrical control board has been removed, altered, or is unreadable.
- Product has been modified or uses non-standard parts not approved by ITR.
- Product has been abused (such as by dropping it), damaged, vandalized, or has received improper maintenance.
- Product has been run dry or operated without appropriate antifreeze, causing damage to the heat exchanger, pump seals, etc.
- Product has been exposed to an environment detrimental to its effective operation, such as excessively wet, dirty, or hot areas.

Also not covered under warranty:

- Parts or Products no longer within the manufacturer's warranty period.
- Parts or Products installed or used in a manner contrary to ITR's printed instructions without ITR's prior written permission.
- Normal wear and tear of parts, including but not limited to, fuel filter, air filter, nozzles, fuses, ignitor, electrical motors, fuel pumps, air compressors, and carbon brushes.
- Product malfunctions due to improper installation of parts or Products, including but not limited to malfunctions causing inadequacies in air, fuel, or coolant flow; voltage problems due to improper wiring; and shock or vibration.
- Progressive damage to the engine or vehicle caused by failure of the Product or an improper installation.
- Diagnosis or repairs to fix problems not directly related to the Product or due to empty fuel tanks or poor fuel quality, fuel additives, acidic water, electrolysis, or any chemical reactions.
- Travel time and expenses by an ITR dealer.
- Removal and re-installation expenses for the ITR heater.

Customer Service Calls

ITR warrants the ITR heater and the Dealer warrants the installation.

If you have a service problem, first check the *Troubleshooting* section of the *Owner's Manual* to determine if your problem is addressed. Also ensure you are familiar with the design and installation setup.

When calling ITR or the Dealer with a service problem, have the following information ready at hand:

- model number and serial number of the Product
- a detailed description of the problem
- your *Installation Manual* and *Owner's Manual*

Depending on your location, an authorized service person may be able to visit your yacht to help troubleshoot problems and repair your Product. Such service calls are at the Owner's expense. Regardless, you must obtain written approval from ITR or the Dealer for any warranty repair before it is undertaken. All repairs done under warranty are subject to the terms and conditions of the flat-rate manual.

Returns

If a service call by an authorized service person is not feasible, the Owner must do the following to obtain warranty service:

1. Immediately contact ITR (or your Dealer) and provide a full description of the problem.
2. Obtain (in writing) a Return or Repair Material Authorization (RMA) number from ITR for any warranty, return, repair, or service. ITR will refuse any return package and will not authorize service or repairs without a RMA number. (For repairs by authorized Dealers, the dealer must obtain an authorized RMA number from ITR before warranty work commences.)
3. When shipping your Product, pack securely, show the RMA and serial number of the Product on the outside of the shipping container, and ship prepaid and insured.
4. Provide written details of the problems, date of installation, proof of purchase, and a return address.

After repair or replacement of the Products still under warranty, ITR will pay return shipping charges. All repairs done under warranty are subject to the terms and conditions of the flat-rate manual.

Telephone / Email Service

Service information given over the telephone, by fax or by email is given only in good faith as an accommodation to the customer. Such information should not be relied upon without an independent verification of its applicability to the customer's particular situation. For customer service or other information, contact:

IN CANADA:

2431 Simpson Road

Richmond, BC, Canada V6X 2R2

Tel: 1-800-755-1272 or 604-278-1272

Fax: 604-278-1274

Email: info@itrheat.com

Website: <http://www.itrheat.com>

IN THE UNITED STATES:

11915 NE 56th Circle, Suite B

Vancouver WA USA 98682

Tel: 1-800-993-4402 or 360-993-4877

Fax: 360-993-1105

Email: info@itrheat.com