

General Heater Layout / Operation

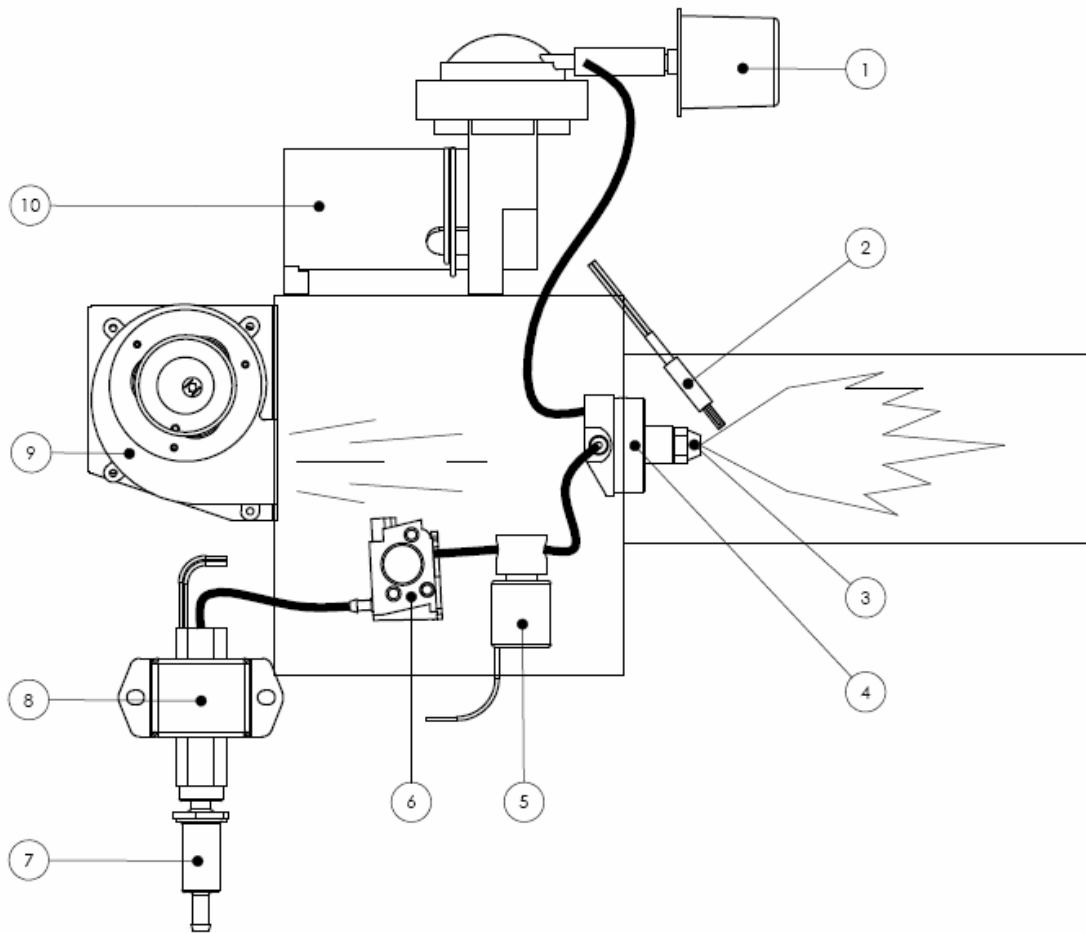

Component Identification:

1. Air filter
2. Igniter
3. Nozzle
4. Nozzle body
5. Fuel shut-off solenoid (There is a thermal cutoff link in the fuel solenoid ground wire that is not shown in the diagram above. See technical bulletin # ETB018-20)
6. Fuel regulator
7. Fuel filter
8. Fuel pump
9. Combustion air fan
10. Compressor

Sequence of operation:

After the remote switch is turned ON and a thermostat is calling for heat, the heater will cycle as follows:

1. The igniter will turn ON and the combustion fan will turn OFF.
2. The igniter will glow for 10 seconds to allow it to reach ignition temperature.
3. After the igniter has been glowing for 10 seconds, the air compressor, fuel pump, fuel solenoid, and the combustion air fan will turn ON.

The air compressor provides a constant air supply to the nozzle under a specific pressure and flow rate. This air is filtered before it enters the compressor. In the nozzle the compressed air is guided over the tip of the nozzle where it creates a negative pressure in the center tube. This negative pressure is used to draw fuel from the fuel regulator. All fuel lines from the regulator to the nozzle must be air tight. Any leaks will have an adverse effect on the flame. The nozzle produces a solid cone pattern spray with extremely fine particles of fuel. This spray is then ignited when it makes contact with the igniter.

The fuel pump pumps fuel from the fuel tank up to the fuel regulator. Before the fuel enters the fuel pump, it passes an internal fuel filter. Fuel is only allowed to pass the regulator when there is a negative pressure between the regulator and the nozzle. In between the regulator and the nozzle is a fuel solenoid. This fuel solenoid prevents the fuel from being drawn back from the nozzle when the burner is off. This allows for a clean ignition.

The combustion fan draws outside air which is used to create a forced air flow through the combustion chamber for optimal combustion and to exhaust the combustion gasses through an exhaust pipe system into the atmosphere.

4. After ignition takes place, the igniter will remain ON for an additional 5 seconds. This is so if there are any air bubbles in the system, the atomized fuel will continue to be ignited.
5. After this 5 second period, the igniter will turn OFF. The air compressor, fuel pump, fuel solenoid, and combustion fan will remain ON. At this point the flame sensor will also look for a flame.

The burner will continue to run until one of the following occurs:

- The coolant inside of the Hurricane reaches the set operating temperature range
- The temperature demand by a thermostat or aquastat (across the W-W terminals) is met
- The burner switch is turned off
- The power button is pressed
- The reset button is pressed
- One of the components fault (Including a thermal cutoff link that is in the fuel solenoid ground wire)
- A flame out occurs
- A voltage fault occurs

Note: After any of the above situations, the combustion fan will run for 2 minutes to purge exhaust gases from the system. The only time the combustion fan will not run after the system cycles/faults/resets is when the combustion fan has faulted. In this case all of the burner components will shut down immediately.

Notes on flame out:

If the flame goes out while the burner is running, the flame sensor will detect a flame-fault after 2 seconds. If the flame goes out during the ignition period (5 seconds), the flame sensor will detect a flame fault 2 seconds after the ignition period (i.e. 7 seconds from the start of the ignition period). After the first flame-fault, the burner will attempt the ignition sequence two more times. If the flame goes out a second time within a 2 minute period of the initial flame out, then the Hurricane will shut down and the combustion fan will purge for 2 minutes and turn OFF.

Notes on voltage fault:

When the voltage goes below 10.5 volts for a period of more than 10 seconds, the Hurricane will shut down. If the voltage goes above 10.5 volts, the heater will restart. If the voltage drops below 10.5 volts a second time within a 2 minute period of the initial low voltage fault, then the Hurricane will shut down and the combustion fan will purge for 2 minutes and turn OFF. The Hurricane will remain in this state until the reset button on the is pressed or until the burner switch on the Hurricane remote operating panel is turned OFF (delay 1 second) and turned ON again.

Bypass Mode

The heater can be tested in bypass mode. This will isolate the electrical component operation from the mechanical components. The heater will operate for up to 5 minutes in the Bypass mode before reverting to the 'normal' operation mode.

To enter the Bypass mode:

1. Turn the main control board power off.
2. Press the Bypass switch (located above the 7 segment display on the V2000/2001 boards and on the front panel of the water heater).
3. While continuing to press the Bypass switch, turn on the main control board power.
4. The Bypass LED will continue to flash for a maximum of 5 minutes, if the heater continues to run.

If the heater will run in bypass mode but not the normal mode it indicates that the mechanical components are operating correctly. The problem is most likely with either the main control board or the digital flame sensor.

Important Note: Do not leave the heater unattended while in the Bypass mode. While in the Bypass mode, the control circuitry will ignore the temperature control aquastats and the digital flame sensor feedback.

Individual component test

Note:

In the tests below, the harness between the control board and the heater must be unplugged from the control board. If the connector is not removed from the control board, the control board may be damaged beyond repair. This in not a warranty item.

Compressor test:

The output of the compressor can be tested using a pressure gauge that is inserted between the compressor and the nozzle body. The nozzle that should be used during this test should be a part number 14017. This is the same nozzle that is used on a CO-45 or H2. Technical bulletin # MTB-101-10 details the configuration and the allowable limits.

To test the compressor, jumper the 2nd wire from the bottom of the connector to +12V DC. This will be a red wire.

Fuel pump/fuel solenoid test:

The output of the fuel pump can be tested using a pressure gauge that is inserted between the fuel pump and the fuel regulator. The pressure should be between 3-5 psi. An alternative test configuration would be to

remove the fuel return between the heater and the fuel tank, open the bleeder valve if one is installed, and pump fuel into a container. The pump will provide up to 25 gallons per hour. Allowing the pump to run for 5 seconds should provide approximately 4.5 oz of fuel into an open container.

Note:

When the fuel pump is tested as stated below, there will be a 'clicking sound' coming from the fuel solenoid that is located near the nozzle body. In normal operation, the fuel solenoid opening will provide fuel flow to the nozzle from the fuel regulator. There is a thermal cutoff link in the fuel solenoid ground wire that will open if the temperature in the pre combustion compartment exceeds 305 degrees F (152C). This will stop all fuel flow to the nozzle body.

To test the fuel pump/solenoid, jumper the 4th wire from the bottom of the connector to +12V DC. This will be a blue wire.

Air fan test:

The combustion air fan can be tested by running the air fan. The fan should be blowing air into the combustion chamber. Holding a piece of paper up to the input of the fan will verify that the air flow is into the fan. The paper will be held in place instead of being blown away from the fan input.

To test the combustion air fan, jumper the 3rd wire from the bottom of the connector to +12V DC. This will be a white wire.

Igniter test:

The igniter can be tested by measuring the current through the device or measuring the resistance. The current should be approximately 6 A with 12V DC applied across the igniter. The resistance will be approximately 2 ohms. To provide the greatest reliability of the heater, replace the igniter every 2-3 cleaning cycles.

Cleaning the nozzle:

The nozzle can be either cleaned or replaced during the service interval of the heater. Replacement simply requires the removal and replacement of the nozzle assembly. Cleaning the nozzle requires the disassembly of the device.

To clean the nozzle:

1. Remove the nozzle from the nozzle body.
2. Point the output of the nozzle up, holding the base with a wrench and unscrew the end of the nozzle.
3. Gently remove the end of the nozzle from the nozzle shaft. Use caution to avoid loosing the distributor that is inside of the nozzle assembly.
4. Remove the o-ring from the shaft.
5. Use a carburetor or parts cleaner to thoroughly clean the interior of the nozzle shaft, nozzle end and distributor.
6. Using care to not damage the new o-ring, install the new o-ring on to the nozzle shaft.
7. Pointing the shaft up, install the clean distributor onto the upper end of the shaft.
8. Screw the nozzle end onto the nozzle shaft. Do not over tighten the nozzle end to the shaft or damage to the distributor may occur.
9. Reinstall the nozzle into the aluminum nozzle body.

Cleaning the heater:

To provide the greatest reliability of the heater, it should be cleaned every 1000 – 1200 hours of operation.

To clean the burn chamber:

1. Remove the pre-combustion chamber cover.
2. Disconnect the igniter wiring.
3. Remove the air hose from the nozzle body. (This will be the hose coming from the compressor.)
4. Pull the nozzle body and the associated wiring clear from the pre-combustion chamber.
5. Unscrew the 4 nuts that are holding in the counter flow tube.
6. Gently remove the counter flow tube from the inside of the boiler. This will require a gently twisting of the tube and holding the air and fuel hoses clear of the tube.
7. Vacuum the ash out of the inside of the boiler. If there are hard deposits on the inside of the chamber, use a brush or a soft scraper to loosen the ash.
8. Replace the counter flow tube, nuts, nozzle body, igniter, hoses and wires in the reverse order that they were removed.
9. Place the pre-combustion chamber cover.

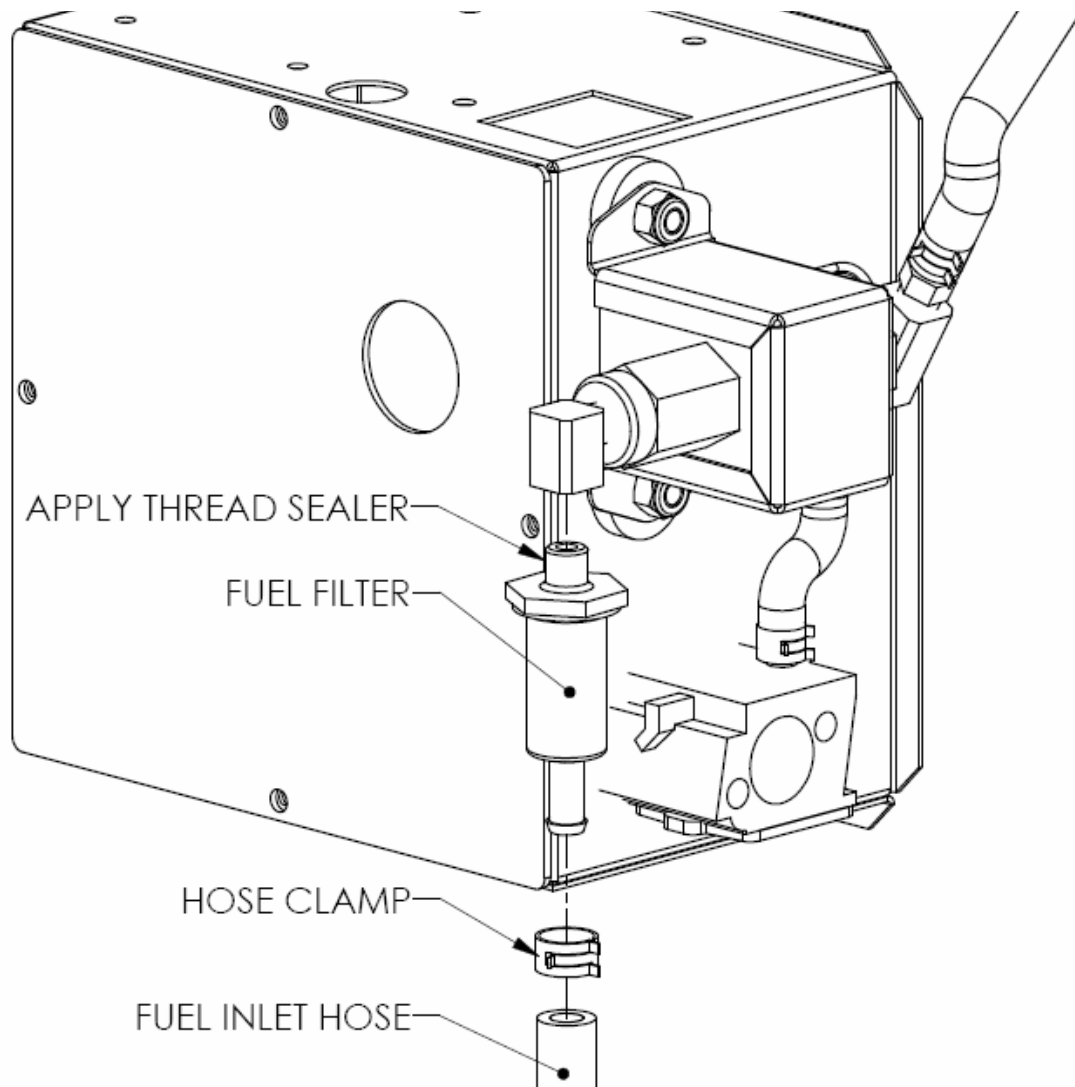

To install/replace the fuel filter, do the following:

1. Turn off the power and allow the heater to completely power down (this will take 2 minutes). Remove the screws on the front panel.
2. Cut the tie wrap that attaches the combustion fan air intake hose to the fuel pump.
3. Before proceeding with the next step, ensure that the fuel supply to the heater is shut off.
4. Remove the fuel line (using a pair of pliers on the hose clamps) from the inlet of the fuel filter.
5. Unscrew the fuel filter (counter-clockwise) from the brass elbow on the inlet of the fuel pump (see Figure 19) using a 15/16" wrench (stabilize the fuel pump by holding the brass elbow using a 9/16" wrench).
6. Place a small amount of thread sealer (compatible with diesel fuel) on the threads of the new fuel filter.
7. Screw in a new fuel filter (clockwise) to the brass elbow on the inlet of the fuel pump and attach the fuel line to the inlet of the fuel filter, ensuring it has been secured with the hose clamp.
8. Secure the air intake hose from the combustion fan to the fuel pump using a tie wrap.
9. Clean up any diesel fuel that was spilt
10. Put the outer cover back in place (tighten screws) and screw in the front cover.