

Because of the unique vaporizing design of the PIONEER heaters, correct draft conditions are essential for the heater to operate in a satisfactory manner.

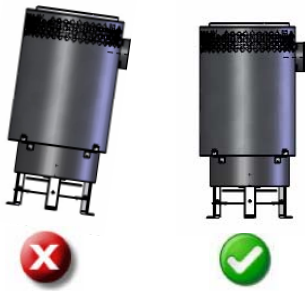

## QUICK INSTALLATION GUIDE for tents and temporary installations

See manual for detailed installation instructions



1. Level the heater, then using mounting screws or bolts, secure it to the floor or a stable base which is at least the maximum width of the heater.

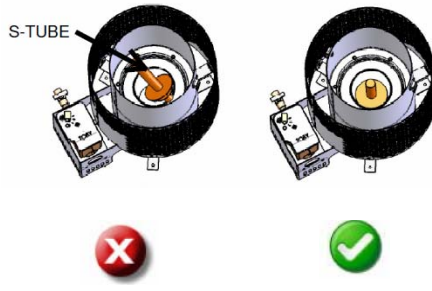

2. During shipping, the S-tube may become dislodged from the center fuel up-tube. If the S-tube has become dislodged, which can be seen through the glass on the lid, the top of the heater must be removed to position the S-tube over the fuel up-tube.

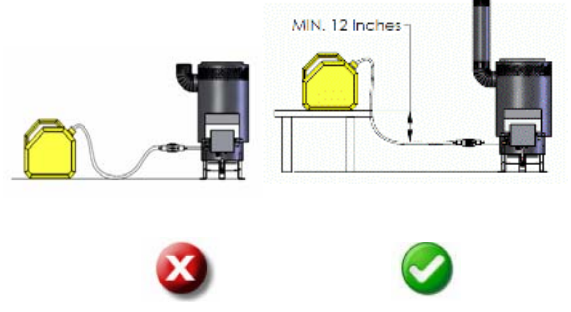

3. Before operating the heater, position the fuel source a minimum of 12" above the level of the fuel inlet to the heater.



4. **DO NOT** operate the heater without both a complete exhaust stack (see page 2) in place and correct draft conditions (see below). Excessive carbon will form in the fuel up-tube and will have to be cleaned out for the heater to function correctly.



5. Non crimped end of exhaust elbow is designed to slide over the heater exhaust collar

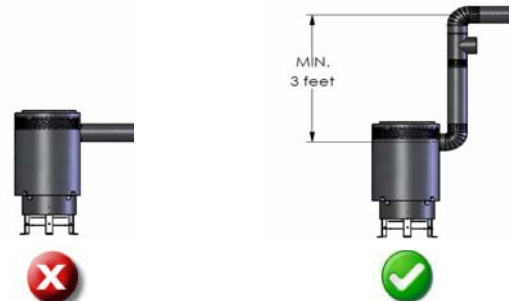

6a. **DO NOT** connect horizontal exhaust stacks directly off the heater (Expedition, Prospector). The heater will not operate correctly and will not stay lit. All heaters (except Trekker) require a 90 degree exhaust elbow and a minimum three foot vertical rise before further elbows and exhaust stack lengths are added.

6b. **DO NOT** use more than 3 feet of horizontal length in the complete exhaust system. Horizontal runs must have a minimum of 1/4" slope rise per foot. See box 8 for sample exhaust systems. Each foot of horizontal length requires 1.5 feet of additional vertical stack height.

7a. **CLEAR THE FUEL LINE OF AIR** The fuel line must be clear of any air prior to operating the heater. Using a fuel line kit or using a solid fuel line shown below.

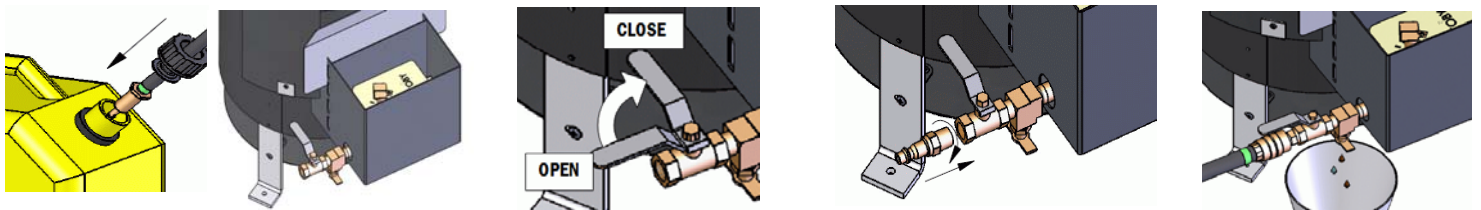

7b. **USING A FUEL LINE KIT** Place the fuel line filter with attached hose into the fuel of the fuel tank. Remove the brass nipple from the kit and apply sealant to the threads. Screw into the ball valve fitting of the heater and tighten until leak free. Do not over tighten or the threads will be damaged and leakage may occur. Connect the fuel line to the heater using the female quick connect fitting. Turn the heater ball valve lever to the OPEN position and open the fuel drain valve. Squeeze the primer bulb until fuel flows in a steady stream from the drain valve. Catch the fuel in a separate container, then close the fuel drain valve. The fuel line is clear of air.

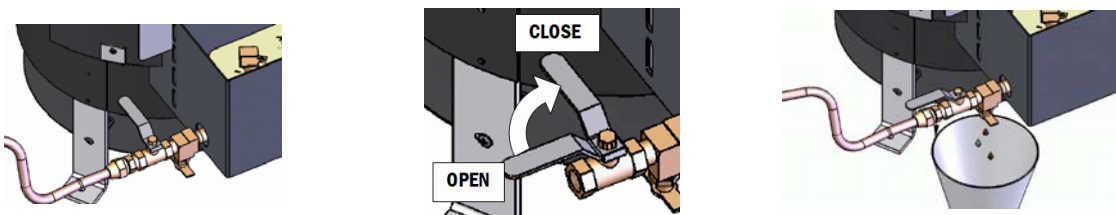

7c. **USING A SOLID FUEL LINE** Connect the solid fuel line to the heater. Turn the ball valve lever to the OPEN position and open the fuel drain valve. Start the fuel flowing from the fuel tank and wait until fuel flows in a steady stream from the drain valve. Catch the fuel in a separate container, then close the fuel drain valve. The fuel line is clear of air.

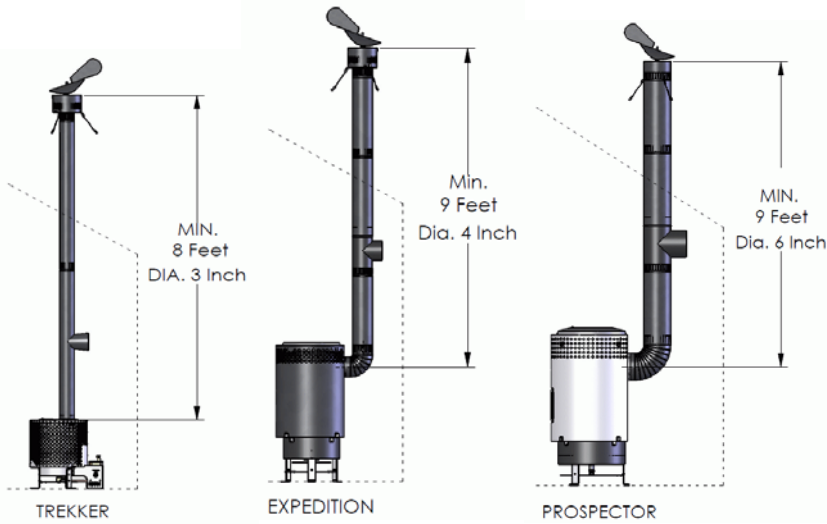

**Exhaust location: angled roof**  
(standard configuration)

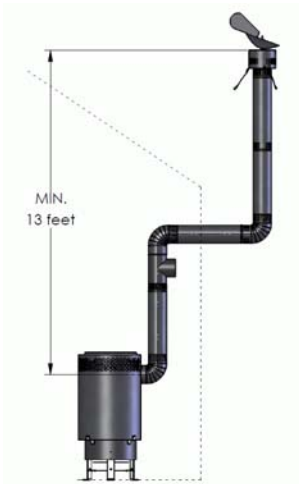

*Expedition heater with a three foot horizontal run.*  
13 feet of vertical stack height in total is required versus the standard 9 feet.

**Exhaust location: vertical sidewall** (optional) configuration

For every 5000ft above sea level, add 2 feet to the vertical exhaust stack height.

**DO NOT** pass the exhaust stack through a combustible wall or roof without heat protection

**8. SAMPLE EXHAUSTS: ROOF EXIT AND SIDEWALL EXIT**

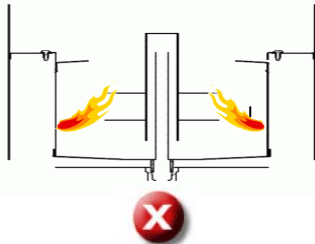

**HIGH DRAFT:** The tips of the flame are at a level lower than the top of the "S" tube.

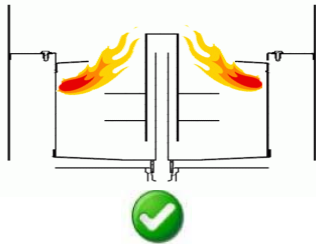

**CORRECT DRAFT:** the tips of the flame are at the same level as the top of the "S" tube

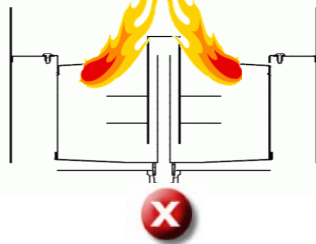

**LOW DRAFT:** The tips of the flame are at a level higher than the top of the "S" tube.

**9a. DRAFT CONDITIONS** All heaters require the proper draft. Estimate the draft by viewing the flame in the burner. See box 9b and 9c. If a draft meter is available, set the heater to the recommended water column reading. See the manual for further details on the use of a draft meter.

**9b. TO ESTIMATE THE DRAFT** Set up the heater with the final exhaust stack configuration in place. Start the heater, and let the heater **operate at the #1 setting (position indicated by the first raised notch) only**. Do not operate the heater at any other setting or the flame will be distorted. After 10 minutes of operation, view the burner flame through the glass lid on the top of the heater. Look for the level of the tips of the flame relative to the top of the S- tube. The correct draft is approximated by the flame tips at the same height as the top of the S-tube.

**9c. TO ADJUST THE DRAFT** In general, the draft can be increased by increasing the existing vertical stack height. Decrease the draft by decreasing the existing vertical stack height. If a draft regulator is present, adjust the settings on the draft regulator until the desired draft setting is reached. Follow the manufacturer's instructions on use of the regulator.

**Follow all government requirements, safety, and building codes in installing and using the heater.**